

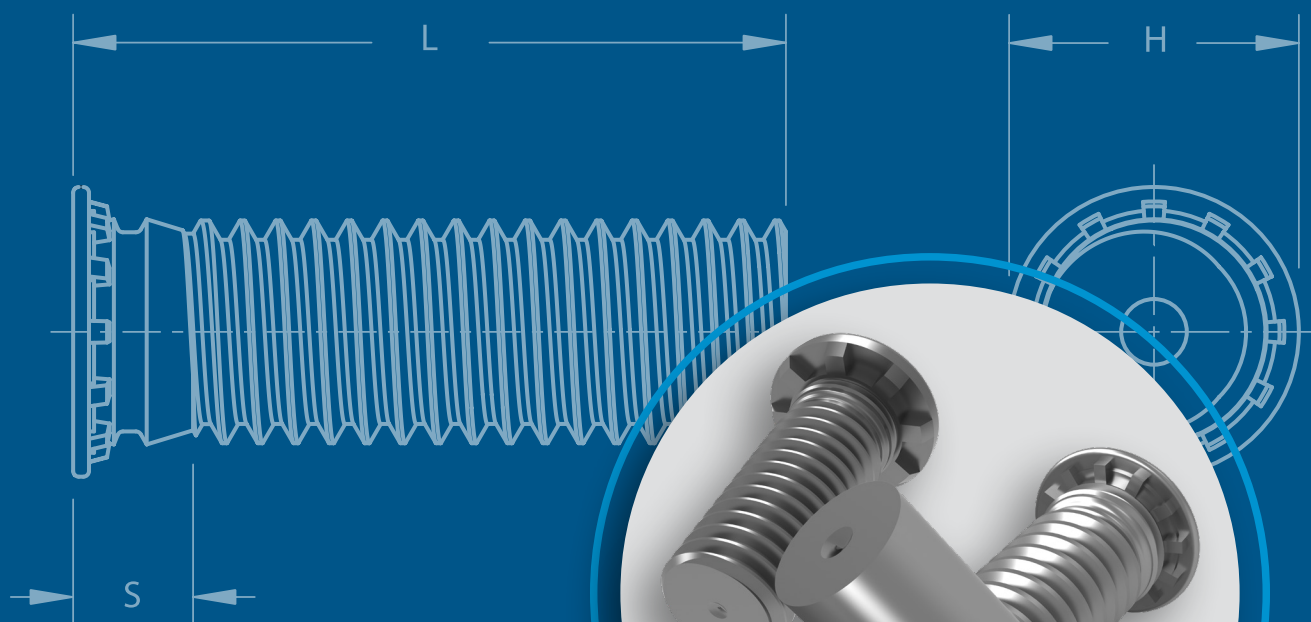

FH™

SELF-CLINCHING STUDS AND PINS



PEM® brand self-clinching studs and pins install permanently in aluminum, steel or stainless steel sheets.

PEM® self-clinching studs are easily installed by placing them in properly sized holes in sheets and squeezing into place with any standard press:

- Install permanently in aluminum, steel or stainless steel in sheets as thin as .020" / 0.51 mm.
- High torque-out and pushout resistances.

Dog Point and Anti Cross-Thread Options

– [PAGE 4](#)



FH™/FHS™/FHA™ (flush-head) studs

are available in aluminum, steel, or stainless steel – [PAGE 5](#)



FH4™/FHP™ (flush-head) studs are designed to provide strong threads in stainless steel sheets as thin as .040"/1 mm. FHP studs have high corrosion resistance – [PAGE 6](#)



FHL™/FHLS™ (flush, low-displacement head) studs have a smaller head diameter and install closer to the edge of a sheet than PEM FH/FHS studs – [PAGE 7](#)



TFH™/TFHS™ (non-flush) studs are for sheets as thin as .020" / 0.51 mm. The stud head will project above the sheet surface approximately .025"/0.64mm – [PAGE 8](#)



HFH™/HFHS™ (heavy-duty) studs have a large head which projects above the sheet material to distribute the axial tightening force over a large area thereby improving pull through resistance – [PAGE 9](#)



HFHB™ (heavy-duty BUSBAR®) studs are ideal for applications which demand superior electrical/mechanical attachment points – [PAGE 9](#)



HFE™/THFE™ (heavy-duty) studs

Provides maximum pull through in sheets as thin as .031" / 0.8 mm - [PAGE 10](#)



HFG8™/HF109™ (heavy-duty high tensile strength) studs are manufactured for the most demanding applications from medium carbon alloy steel, then heat-treated to high strength and hardness qualities – [PAGE 11](#)



HFLH™ studs are for installation into thin, harder, high-strength materials – [PAGE 12](#)



SGPC™ swaging collar studs can install into most panel material and accommodate multiple panels as long as the total thickness does not exceed the maximum sheet thickness – [PAGE 13](#)



FHX™ flush-head studs with X-Press™ thread profile are typically used with push-on or other plastic fasteners – [PAGE 14](#)



FH™/FHS™/FHA™ (flush-head) Pins are available on special order – [PAGE 15](#)



TPS™/TP4™/TPXS™ (flush-head) pilot pins satisfy a wide range of positioning, pivot, and alignment applications – [PAGE 16](#)



Material and finish specifications – [PAGE 17](#)

Installation – [PAGES 18 - 29](#)

Performance data – [PAGES 29 - 35](#)

Fastener drawings and models are available at www.pemnet.com. Custom sizes are available on special order. [Contact us](#) for more information.

Page 5



Flush-head studs
Types FH/FHA/FHS/FHP/FH4

Page 7

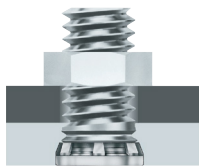

Flush, low-displacement head studs
Types FHL/FHLS

Page 8



Thin sheet studs
Types TFH/TFHS

Page 9

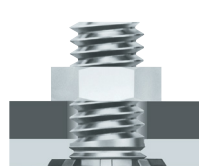

Heavy-duty studs
Types HFH/HFHS/HFHB

Page 10

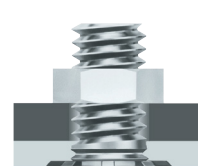

Heavy-duty studs for thin sheets
Types HFE/THFE

Stud Selector Guide

PEM Stud Type	Application Requires:											
	Flush-head	Heavy duty	Sheet thickness as thin as .020" / 0.51 mm	Superior electrical conductivity	Installation into stainless steel sheets	Compatibility with aluminum anodizing	Superior corrosion resistance	Closest centerline-to-edge distance	Unthreaded stud/pin	Largest hole in attached Panel	Non-magnetic	Max. panel hardness (2)
FH	▪											HRB 80 HB 150
FHA	▪					▪	▪				▪	HRB 50 HB 82
FHS	▪						▪				▪	HRB 70 HB 125
FH4	▪				▪							HRB 92 HB 202
FHP	▪				▪		▪				▪	HRB 92 HB 202
FHL	▪							▪				HRB 80 HB 150
FHLS	▪						▪	▪			▪	HRB 70 HB 125
TFH			▪									HRB 80 HB 150
TFHS			▪				▪				▪	HRB 70 HB 125
HFH		▪ (1)								▪		HRB 85 HB 165
HFHB		▪		▪			▪			▪	▪	HRB 55 HB 83
HFHS		▪					▪			▪	▪	HRB 70 HB 125
HFE		▪								▪		HRB 85 HB 165
THFE		▪								▪		HRB 85 HB 165
HFG8/HF109		▪ (3)								▪		HRB 89 HB 180
HFLH		▪								▪		HRB 96 HB 216
SGPC					▪			▪			▪	Any sheet hardness
FHX	▪											HRB 80 HB 150
FH Unthreaded	▪								▪			HRB 80 HB 150
FHA Unthreaded	▪					▪	▪		▪		▪	HRB 50 HB 82
FHS Unthreaded	▪						▪		▪		▪	HRB 70 HB 125
TPS	▪						▪		▪		▪	HRB 70 HB 125
TP4	▪				▪				▪			HRB 92 HB 202
TPXS	▪						▪		▪		▪	HRB 70 HB 125

(1) Meets grade 5 / property class 9.8 tensile requirements.
 (2) HRB - Hardness Rockwell "B" Scale, HB - Hardness Brinell.
 (3) Grade 8 / Property Class 10.9 thread strength.
 Standard product features shown above. Studs can also be custom designed to meet your exact application requirements.

Page 11

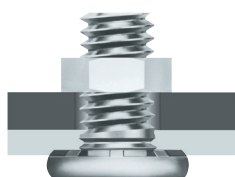

Heavy-duty, high tensile strength studs
Types HFG8/HF109

Page 12



Studs for hard panels
Type HFLH

Page 13

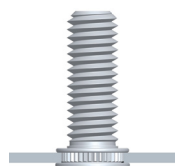

Swaging collar studs
Type SGPC

Page 14

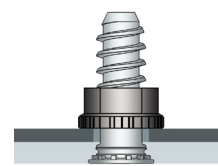

Flush-head Studs with
X-Press™ Thread Profile
Type FHX

Page 16



Flush-head pins
Types TPS/TP4

Optional Dog Point Feature

PEM® dog point lead-in option for studs allows quick location of the mating fastener during assembly and protects the first thread of the stud during nut engagement. This feature is available on Types FH, FHL, HFH, HFE, HF109, HFG8, TFH and THFE studs.

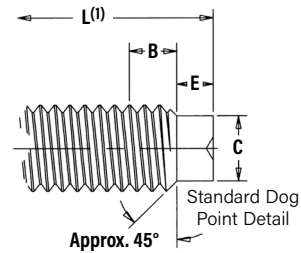

All dimensions are in inches.

All dimensions are in millimeters.

Unified Thread Size	C ±.005 (2)	E ±.010	B Nom. Transitional Length to Full Thread	Metric Thread Size	C ±0.13 (2)	E ±0.25	B nom. Transitional Length to Full Thread
.138-32 (#6-32)	.086	.050	.098	M3.5 x 0.6	2.4	1.27	1.88
.164-32 (#8-32)	.111	.055	.099	M4 x 0.7	2.79	1.4	2.26
.190-24 (#10-24)	.124	.065	.127	M5 x 0.8	3.66	1.78	2.48
.190-32 (#10-32)	.138	.065	.098	M6 x 1	4.37	2.03	3.05
.250-20 (1/4-20)	.173	.085	.149	M8 x 1.25	6.05	2.67	3.73
.250-28 (1/4-28)	.192	.085	.110	M10 x 1.5	7.72	3.43	4.37
.313-18 (5/16-18)	.228	.105	.164				
.313-24 (5/16-24)	.246	.105	.127				
.375-16 (3/8-16)	.282	.125	.182				
.375-24 (3/8-24)	.309	.125	.126				

(1) For "L" refer to type stud lengths.

(2) Maximum dog point diameter is .003" / 0.08 mm less than minimum minor diameter of 2B or 6H nut threads.

Optional Part Number Designation

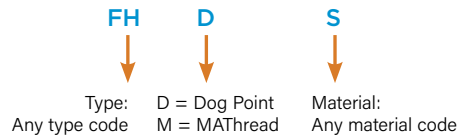

Optional MATHread® Anti Cross-Thread Feature

PennEngineering is a licensee of MATHread® Anti Cross-Threading Technology. This unique design allows the threads to self-align and drive easily with reduced effort. This helps speed assembly, reduce or eliminate failures, repairs, scrap, downtime, and warranty service associated with thread damage. This option is available on most types of PEM® studs.



Anti Cross-Thread Feature

MATHread is a registered trademark of MATHread inc.

Optional Pointed Stud Feature

A pointed lead-in option for studs allows quick location of mating fastener during assembly to speed assembly and significantly reduces the likelihood of cross threading. Clip grooves for snap rings can also be added. This feature can be added to most types of PEM® studs.

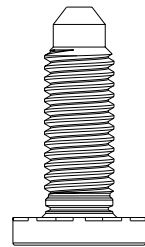

Optional Thread Mask

Thread mask is available for applications where hardware is installed prior to painting. During assembly, the threads of the mating hardware will remove paint, electro deposited automotive under coatings, and weld spatter upon application of torque. PEM® studs can be specially ordered with thread mask applied. [Click here](#) for more information.



Thread mask color may vary.

"BC" suffix will be added to part number to designate thread mask to fastener.

Available Pem® VariMount® Fastening System

The PEM® VariMount® fastening system (see PEM® Bulletin VM) utilizes a self-clinching stud paired with a round steel or stainless steel base plate to offer a clean and ready-made assembly for mounting into any rigid material or panel, including composites, plastics, and metals. Multiple radial holes in the base plate and a generous footprint provide effective mounting of the assembly. Mounting can be performed either on the front or through the back of a panel.



FH™/FHS™/FHA™ Flush-Head Studs

- Flush-head for sheet thickness of .040" / 1 mm and greater.
- FH studs are recommended for use in steel or aluminum sheets HRB (Rockwell "B" scale) 80 / HB (Hardness Brinell) 150 or less.
- FHS studs are recommended for use in steel or aluminum sheets HRB (Rockwell "B" scale) 70 / HB (Hardness Brinell) 125 or less.
- FHA studs are recommended for use in aluminum sheets HRB (Rockwell "B" scale) 50 / HB (Hardness Brinell) 82 or less.

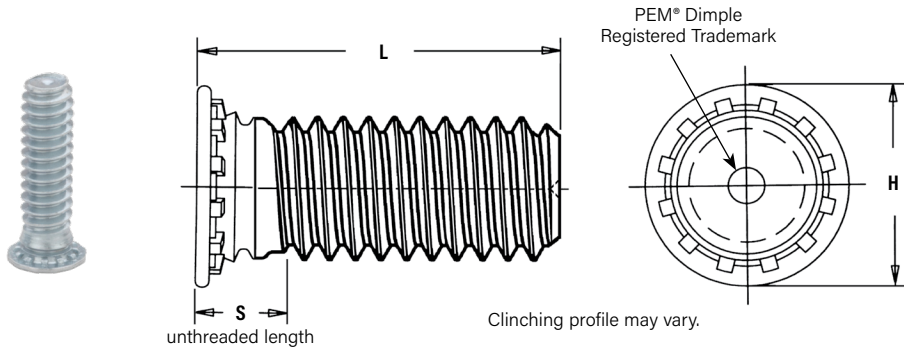

Part Number Designation

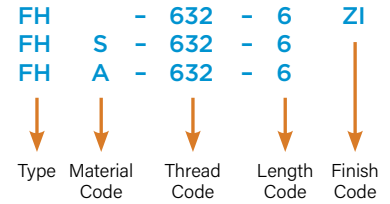

All dimensions are in inches.

Unified	Thread Size	Type			Thread Code	Length Code "L" ±.015 (Length Code in 16ths of an inch)										Min. Sheet Thickness (1)	Hole Size in Sheet +.003 - .000	H ± .015	S Max. (2)	Max. Hole in Attached Parts	Min. Dist. Hole C/L to Edge (3)
		Fastener Material																			
		Steel	Stainless Steel	Aluminum		.250	.312	.375	.500	.625	.750	.875	1.00	1.25	1.50						
.086-56 (#2-56)	FH	FHS	—	256	4	5	6	8	10	12	—	—	—	—	.040	.085	.144	.075	.105	.187	
.112-40 (#4-40)	FH	FHS	FHA	440	4	5	6	8	10	12	14	16	20	—	.040	.111	.176	.085	.135	.219	
.138-32 (#6-32)	FH	FHS	FHA	632	4	5	6	8	10	12	14	16	20	24	.040	.137	.206	.090	.160	.250	
.164-32 (#8-32)	FH	FHS	FHA	832	4	5	6	8	10	12	14	16	20	24	.040	.163	.237	.090	.185	.281	
.190-24 (#10-24)	FH	FHS	FHA	024	—	5	6	8	10	12	14	16	20	24	.040	.189	.256	.100	.210	.281	
.190-32 (#10-32)	FH	FHS	FHA	032	—	5	6	8	10	12	14	16	20	24	.040	.189	.256	.100	.210	.281	
.250-20 (1/4-20)	FH	FHS	FHA	0420	—	—	6	8	10	12	14	16	20	24	.062	.249	.337	.135	.270	.312	
.313-18 (5/16-18)	FH	FHS	—	0518	—	—	—	8	10	12	14	16	20	24	.093	.311	.376	.160	.333	.375	

All dimensions are in millimeters.

Metric	Thread Size x Pitch	Type			Thread Code	Length Code "L" ±0.4 (Length Code in millimeters)										Min. Sheet Thickness (1)	Hole Size in Sheet +0.08	H ± 0.4	S Max. (2)	Max. Hole in Attached Parts	Min. Dist. Hole C/L to Edge (3)
		Fastener Material																			
		Steel	Stainless Steel	Aluminum		6	8	10	12	15	18	—	—	—	—						
M2.5 x 0.45	FH	FHS	FHA	M2.5	6	8	10	12	15	18	—	—	—	—	1	2.5	4.1	1.95	3.1	5.4	
M3 x 0.5	FH	FHS	FHA	M3	6	8	10	12	15	18	20	25	—	—	1	3	4.6	2.1	3.6	5.6	
M3.5 x 0.6	FH	FHS	FHA	M3.5	6	8	10	12	15	18	20	25	30	—	1	3.5	5.3	2.25	4.1	6.4	
M4 x 0.7	FH	FHS	FHA	M4	6	8	10	12	15	18	20	25	30	35	1	4	5.9	2.4	4.6	7.2	
M5 x 0.8	FH	FHS	FHA	M5	—	8	10	12	15	18	20	25	30	35	1	5	6.5	2.7	5.6	7.2	
M6 x 1	FH	FHS	FHA	M6	—	—	10	12	15	18	20	25	30	35	1.6	6	8.2	3	6.6	7.9	
M8 x 1.25	FH	FHS	—	M8	—	—	—	12	15	18	20	25	30	35	2.4	8	9.6	3.7	8.6	9.6	

- (1) See page 18 for installation tool requirements.
- (2) Threads are gaugeable to within 2 pitches of the "S" Max. dimension. A class 3B/5H maximum material commercial nut shall pass up to the "S" Max. dimension.
- (3) For more information on proximity to bends and distance to other clinch hardware, see PEM® Tech Sheet C/L To Edge.

FH4™/FHP™ Flush-Head Studs For Stainless Steel Sheets

- FHP studs offer optimum corrosion resistance and are ideal for medical, foodservice, and marine applications.
- Recommended for use in stainless steel sheets HRB (Rockwell "B" Scale) 92 / HB (Hardness Brinell) 195 or less.

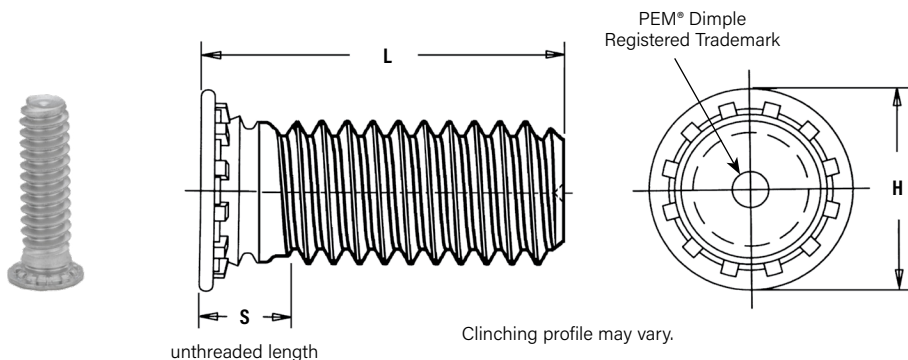

Part Number Designation

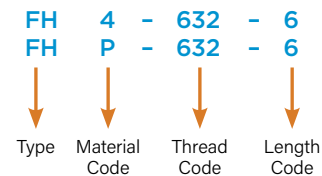

All dimensions are in inches.

Unified	Thread Size	Type		Thread Code	Length Code "L" ±.015 (Length code in 16ths of an inch)										Sheet Thickness (2)	Hole Size in Sheet +.003 - .000	H ±.015	S Max. (3)	Max. Hole in Attached Parts	Min. Dist. Hole C/L to Edge (4)
		Fastener Material			.250	.312	.375	.500	.625	.750	.875	1.00	1.25	1.50						
		Stainless Steel (1)																		
	.112-40 (#4-40)	FH4	FHP	440	4	5	6	8	10	12	14	16	—	—	.040-.095	.111	.176	.085	.131	.219
.138-32 (#6-32)	FH4	FHP	632	4	5	6	8	10	12	14	16	20	24	.040-.095	.137	.206	.090	.157	.250	
.164-32 (#8-32)	FH4	FHP	832	4	5	6	8	10	12	14	16	20	24	.040-.095	.163	.237	.090	.183	.281	
.190-32 (#10-32)	FH4	FHP	032	—	5	6	8	10	12	14	16	20	24	.040-.095	.189	.256	.100	.209	.281	
.250-20 (1/4-20)	FH4	—	0420	—	—	6	8	10	12	14	16	20	24	.062-.117	.249	.337	.135	.269	.312	

All dimensions are in millimeters.

Metric	Thread Size x Pitch	Type		Thread Code	Length Code "L" ±0.4 (Length Code in millimeters)										Sheet Thickness (2)	Hole Size in Sheet +0.08	H ±0.4	S Max. (3)	Max. Hole in Attached Parts	Min. Dist. Hole C/L to Edge (4)
		Fastener Material			6	8	10	12	15	18	20	25	30	35						
		Stainless Steel (1)																		
	M3 x 0.5	FH4	FHP	M3	6	8	10	12	15	18	20	25	—	—	1 - 2.4	3	4.6	2.1	3.3	5.6
M4 x 0.7	FH4	FHP	M4	6	8	10	12	15	18	20	25	30	35	1 - 2.4	4	5.9	2.4	4.7	7.2	
M5 x 0.8	FH4	FHP	M5	—	8	10	12	15	18	20	25	30	35	1 - 2.4	5	6.5	2.7	5.3	7.2	
M6 x 1	FH4	—	M6	—	—	10	12	15	18	20	25	30	35	1.6 - 3	6	8.2	3	6.8	7.9	

- (1) See material and finish specifications chart on page 17 for details.
- (2) See page 19 for installation tool requirements. Performance may be reduced for studs installed into thicker sheets.
- (3) Threads are gaugeable to within 2 pitches of the "S" Max. dimension. A class 3B/5H maximum material commercial nut shall pass up to the "S" Max. dimension.
- (4) For more information on proximity to bends and distance to other clinch hardware, see [PEM® Tech Sheet C/L To Edge](#).

A Note About 400 Series Fasteners For Stainless Steel Panels

In order for self-clinching fasteners to work properly, the fastener must be harder than the sheet into which it is being installed. In the case of stainless steel panels, fasteners made from 300 Series Stainless Steel do not meet this hardness criteria. For this reason, we offer FH4™ and TP4™ 400 series fasteners. However, while these 400 Series fasteners install and perform well in 300 Series stainless sheets they should not be used if the end product:

- Will be exposed to any appreciable corrosive presence.
- Requires non-magnetic fasteners.
- Will be exposed to any temperatures above 300°F (149°C)

If any of these are issues, please contact techsupport@pemnet.com for other options such as the FHP™ stud, made from precipitation hardened grade stainless steel which is not subject to these issues.

FHL™/FHLS™ Flush, Low-Displacement Head Studs

- Installs closer to the edge of a sheet than PEM Type FH/FHS studs without causing that edge to bulge.
- Flush-head for sheet thickness .040" / 1 mm and greater.
- FHL studs are recommended for use in steel or aluminum sheets HRB (Rockwell "B" Scale) 80 / HB (Hardness Brinell) 150 or less.
- FHLS studs are recommended for use in steel or aluminum sheets HRB (Rockwell "B" Scale) 70 / HB (Hardness Brinell) 125 or less.

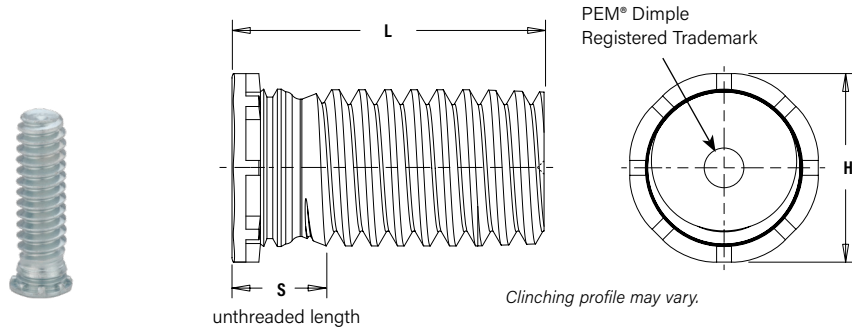

PART NUMBER DESIGNATION

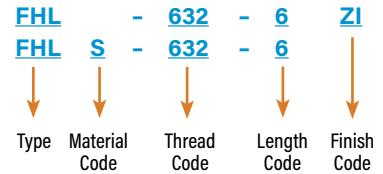

All dimensions are in inches.

Unified	Thread Size	Type		Thread Code	Length Code "L" ±.015 (Length Code in 16ths of an inch)										Min. Sheet Thickness (1)	Hole Size in Sheet +.003 -.000	H ±.015	S Max. (2)	Max. Hole in Attached Parts	Min. Dist. Hole C/L to Edge (3)
		Fastener Material			.250	.312	.375	.500	.625	.750	.875	1.00	1.25	1.50						
		Steel	Stainless Steel																	
.086-56 (#2-56)	FHL	FHLS	256	4	5	6	8	10	12	—	—	—	—	.040	.085	.112	.080	.100	.098	
.112-40 (#4-40)	FHL	FHLS	440	4	5	6	8	10	12	14	16	—	—	.040	.111	.138	.085	.126	.124	
.138-32 (#6-32)	FHL	FHLS	632	4	5	6	8	10	12	14	16	20	24	.040	.137	.164	.090	.152	.150	
.164-32 (#8-32)	FHL	FHLS	832	4	5	6	8	10	12	14	16	20	24	.040	.163	.190	.090	.178	.176	
.190-32 (#10-32)	FHL	FHLS	032	—	5	6	8	10	12	14	16	20	24	.040	.189	.225	.100	.204	.210	

All dimensions are in millimeters.

Metric	Thread Size x Pitch	Type		Thread Code	Length Code "L" ±0.4 (Length Code in millimeters)										Min. Sheet Thickness (1)	Hole Size in Sheet +0.08	H ±0.4	S Max. (2)	Max. Hole in Attached Parts	Min. Dist. Hole C/L to Edge (3)
		Fastener Material			6	8	10	12	15	18	—	—	—	—						
		Steel	Stainless Steel																	
M2.5 x 0.45	FHL	FHLS	M2.5	6	8	10	12	15	18	—	—	—	—	1	2.5	3.15	2.1	2.9	2.8	
M3 x 0.5	FHL	FHLS	M3	6	8	10	12	15	18	20	25	—	—	1	3	3.65	2.1	3.2	3.3	
M3.5 x 0.6	FHL	FHLS	M3.5	6	8	10	12	15	18	20	25	30	—	1	3.5	4.15	2.3	3.9	3.8	
M4 x 0.7	FHL	FHLS	M4	6	8	10	12	15	18	20	25	30	35	1	4	4.65	2.4	4.5	4.3	
M5 x 0.8	FHL	FHLS	M5	—	8	10	12	15	18	20	25	30	35	1	5	5.9	2.7	5.2	5.6	

- (1) See page 19 for installation tool requirements.
- (2) Threads are gaugeable to within 2 pitches of the "S" Max. dimension. A class 3B/5H maximum material commercial nut shall pass up to the "S" Max. dimension.
- (3) For more information on proximity to bends and distance to other clinch hardware, see [PEM® Tech Sheet C/L To Edge](#).

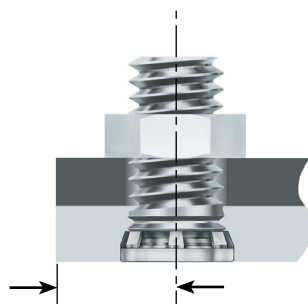

Depending on thread size, FHL studs can be installed almost 50% closer to the edge of a sheet than PEM FH/FHS studs.

TFH™/TFHS™ Non-Flush Studs

- Non-flush for sheets as thin as .020" / 0.51 mm.
- TFH studs are recommended for use in steel or aluminum sheets HRB (Rockwell "B" Scale) 80 / HB (Hardness Brinell) 150 or less.
- TFHS studs are recommended for use in steel or aluminum sheets HRB (Rockwell "B" Scale) 70 / HB (Hardness Brinell) 125 or less.

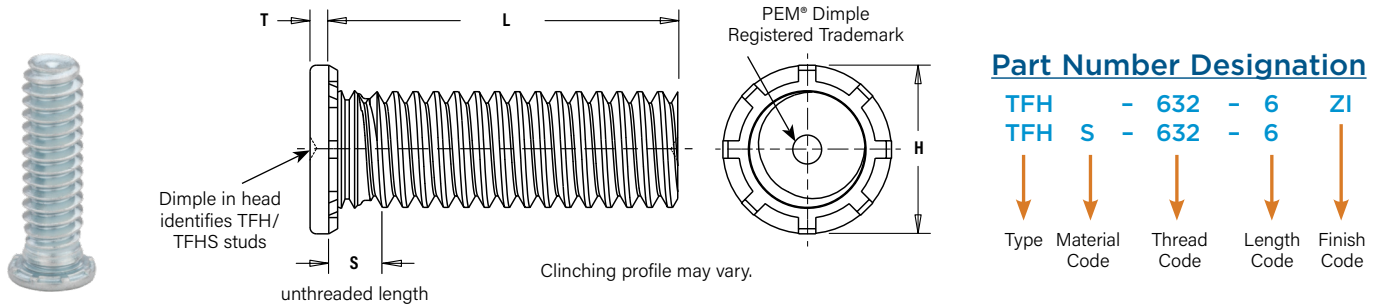

All dimensions are in inches.

Unified	Thread Size	Type		Thread Code	Length Code "L" ±.015 (Length Code in 16ths of an inch)									Min. Sheet Thickness (1)	Hole Size in Sheet +.003 -0.000	H ±.015	S Max. (2)	T Max.	Max. Hole in Attached Parts	Min. Dist. Hole C/L to Edge (3)	
		Fastener Material																			
		Steel	Stainless Steel																		
	.086-56 (#2-56)	TFH	TFHS	256	.250	.312	.375	.500	.625	.750	.875	1.00	1.25	1.50	.020	.085	.141	.070	.025	.105	.187
	.112-40 (#4-40)	TFH	TFHS	440	.250	.312	.375	.500	.625	.750	.875	1.00	1.25	1.50	.020	.111	.176	.070	.025	.131	.219
	.138-32 (#6-32)	TFH	TFHS	632	.250	.312	.375	.500	.625	.750	.875	1.00	1.25	1.50	.020	.137	.203	.070	.025	.157	.250
	.164-32 (#8-32)	TFH	TFHS	832	.250	.312	.375	.500	.625	.750	.875	1.00	1.25	1.50	.020	.163	.234	.070	.025	.183	.281
	.190-24 (#10-24)	TFH	TFHS	024	.250	.312	.375	.500	.625	.750	.875	1.00	1.25	1.50	.020	.189	.250	.090	.025	.209	.281
	.190-32 (#10-32)	TFH	TFHS	032	.250	.312	.375	.500	.625	.750	.875	1.00	1.25	1.50	.020	.189	.250	.090	.025	.209	.281

All dimensions are in millimeters.

Metric	Thread Size x Pitch	Type		Thread Code	Length Code "L" ±0.4 (Length Code in millimeters)									Min. Sheet Thickness (1)	Hole Size in Sheet +0.08	H ±0.4	S Max. (2)	T Max.	Max. Hole in Attached Parts	Min. Dist. Hole C/L to Edge (3)	
		Fastener Material																			
		Steel	Stainless Steel																		
	M3 x 0.5	TFH	TFHS	M3	6	8	10	12	15	18	20	25	-	-	0.51	3	4.5	1.8	0.64	3.3	5.6
	M4 x 0.7	TFH	TFHS	M4	-	8	10	12	15	18	20	25	30	35	0.51	4	5.8	1.8	0.64	4.7	7.2
	M5 x 0.8	TFH	TFHS	M5	-	8	10	12	15	18	20	25	30	35	0.51	5	6.4	2.3	0.64	5.3	7.2

- (1) See page 20 for installation tool requirements.
- (2) Threads are gaugeable to within 2 pitches of the "S" Max. dimension. A class 3B/5H maximum material commercial nut shall pass up to the "S" Max. dimension.
- (3) For more information on proximity to bends and distance to other clinch hardware, see [PEM® Tech Sheet C/L To Edge](#).

HFH™/HFHS™/HFHB™ Heavy-Duty Studs

- HFH studs are for high-strength applications in sheets as thin as .050" / 1.3 mm.
- HFHS studs offer high corrosion resistance.
- HFHB studs are for superior electrical/mechanical attachment in copper.
- HFH studs are recommended for use in steel or aluminum sheets HRB (Rockwell "B" Scale) 85 / HB (Hardness Brinell) 165 or less.
- HFHS studs are recommended for use in steel or aluminum sheets HRB (Rockwell "B" Scale) 70 / HB (Hardness Brinell) 125 or less.
- HFHB studs are recommended for use in copper sheets HRB (Rockwell "B" Scale) 55 / HB (Hardness Brinell) 83 or less.

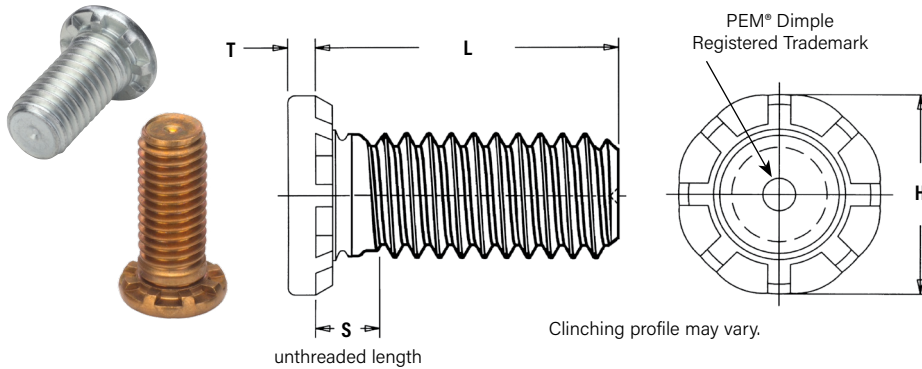

Part Number Designation

HFH	-	032	-	12	ZI
HFH	S	-	032	-	12
HFH	B	-	032	-	12
↓	↓	↓	↓	↓	↓
Type	Material Code	Thread Code	Length Code	Finish Code	

All dimensions are in inches.

Unified	Thread Size	Type			Thread Code	Length Code "L" ±.015 (Length Code in 16ths of an inch)							Min. Sheet Thickness (2)	Hole Size in Sheet +.005 - .000	H ±.01	S Max. (3)	T Max.	Max. Hole in Attached Parts	Min. Dist. Hole C/L to Edge (4)
		Fastener Material																	
		Steel	Stainless Steel	Phosphor Bronze (1)		.500	.750	1.00	1.25	1.50	1.75	2.00							
	.190-32 (#10-32)	HFH	HFHS	HFHB	032	8	12	16	20	24	28	32	.050	.190	.300	.105	.040	.252	.415
	.250-20 (1/4-20)	HFH	HFHS	HFHB	0420	8	12	16	20	24	28	32	.060	.250	.380	.125	.050	.312	.460
	.313-18 (5/16-18)	HFH	HFHS	HFHB	0518	8	12	16	20	24	28	32	.075	.312	.480	.140	.070	.374	.500
	.375-16 (3/8-16)	HFH	HFHS	HFHB	0616	-	12	16	20	24	28	32	.090	.375	.580	.155	.085	.437	.530

Tensile strength: HFH - 120 ksi / HFHS - 75 ksi / HFHB - 60 ksi.

All dimensions are in millimeters.

Metric	Thread Size x Pitch	Type			Thread Code	Length code "L" ±0.4 (Length Code in millimeters)							Min. Sheet Thickness (2)	Hole Size in Sheet +0.13	H ±0.25	S Max. (3)	T Max.	Max. Hole in Attached Parts	Min. Dist. Hole C/L to Edge (4)
		Fastener Material																	
		Steel	Stainless Steel	Phosphor Bronze(1)		15	20	25	30	35	40	50							
	M5 x 0.8	HFH	HFHS	HFHB	M5	15	20	25	30	35	40	50	1.3	5	7.8	2.7	1.14	6.4	10.7
	M6 x 1	HFH	HFHS	HFHB	M6	15	20	25	30	35	40	50	1.5	6	9.4	2.8	1.27	7.5	11.5
	M8 x 1.25	HFH	HFHS	HFHB	M8	15	20	25	30	35	40	50	2	8	12.5	3.5	1.78	9.5	12.7
	M10 x 1.5	HFH	HFHS	HFHB	M10	15	20	25	30	35	40	50	2.3	10	15.7	4.1	2.29	11.5	13.7

Tensile strength: HFH - 900 MPa / HFHS - 515 MPa / HFHB - 415 MPa.

- (1) The electrical resistance (tested at 10 amps DC) between phosphor bronze studs and copper busbars is below 104μ ohms and 62μ ohms for the #10-32 / M5 and 3/8-16 / M10 thread sizes respectively, after repeated thermal and mechanical cycling. For complete electrical resistance test data for type HFHB studs installed in copper, see bulletin entitled "Electrical Resistance of HFHB Studs Installed in Copper" on our website.
- (2) See page 20 for installation tool requirements.
- (3) Threads are gaugeable to within 2 pitches of the "S" Max. dimension. A class 3B/5H maximum material commercial nut shall pass up to the "S" Max. dimension.
- (4) For more information on proximity to bends and distance to other clinch hardware, see [PEM® Tech Sheet C/L To Edge](#).

HFE™/THFE™ Heavy Duty Studs For Thin Sheets

- Enlarged head diameter reduces stress on panel.
- Thicker head allows for larger hole in attached panels.
- Clinch design provides high-strength in sheets as thin as .031" / 0.8 mm.
- Recommended for use in steel or aluminum sheets HRB (Rockwell "B" Scale) 85 / HB (Hardness Brinell) 165 or less.

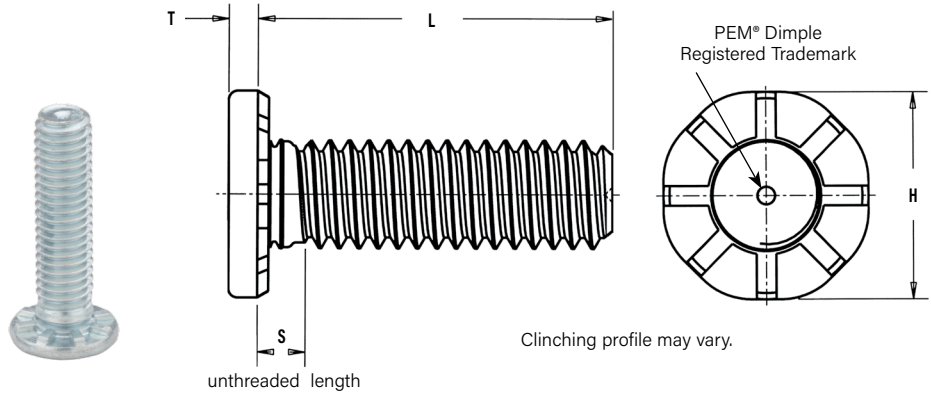

Part Number Designation

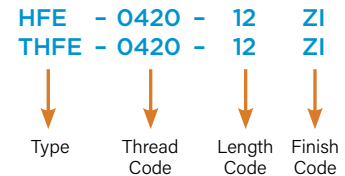

All dimensions are in inches.

Unified	Thread Size	Type	Thread Code	Length Code "L" ±.015 (Length Code in 16ths of an inch)						Min. Sheet Thickness (1)	Hole Size In Sheet +.005 -.000	H ±.01	S Max. (2)	T Max.	Max. Hole in Attached Parts	Min. Dist. Hole C/L to Edge (3)
		Fastener Material		.500	.750	1.00	1.25	1.50	1.75							
	Steel															
.190-32 (#10-32)	HFE	032	8	12	16	20	24	28	32	.040	.190	.357	.102	.048	.280	.360
	THFE	0420	8	12	16	20	24	28	32	.040 .031	.250	.462	.118 .109	.060 .069	.340	.470 .446
.313-18 (5/16-18)	HFE	0518	8	12	16	20	24	28	32	.060	.312	.586	.133	.083	.402	.560
	THFE	0518	8	12	16	20	24	28	32	.060 .031	.312	.586	.117 .099	.099	.402	.596

Tensile strength: 120 ksi

All dimensions are in millimeters.

Metric	Thread Size x Pitch	Type	Thread Code	Length Code "L" ±0.4 (Length Code in millimeters)						Min. Sheet Thickness (1)	Hole Size In Sheet +0.13	H ±0.25	S Max. (2)	T Max.	Max. Hole in Attached Parts	Min. Dist. Hole C/L to Edge (3)
		Fastener Material		15	20	25	30	35	40							
	Steel															
M5 x 0.8	HFE	M5	15	20	25	30	35	40	50	1	5	9.6	2.6	1.35	7.3	10
	THFE	M6	15	20	25	30	35	40	50	1 0.8	6	11.35	2.8 2.62	1.52 1.7	8.3	11.5 10.5
M8 x 1.25	HFE	M8	15	20	25	30	35	40	50	1.5	8	15.3	3.3	2.13	10.3	14.5
	THFE	M8	15	20	25	30	35	40	50	1.5 0.8	8	15.3	2.9 2.54	2.54	10.3	15

Tensile strength: 900 MPa

- (1) See page 21 for installation tool requirements.
- (2) Threads are gaugeable to within 2 pitches of the "S" Max. dimension. A class 3B/5H maximum material commercial nut shall pass up to the "S" Max. dimension.
- (3) For more information on proximity to bends and distance to other clinch hardware, see [PEM® Tech Sheet C/L To Edge](#).

HFG8™/HF109™ Heavy Duty, High Tensile Strength Studs

- HFG8 and HF109 studs are for heavy-duty applications in sheets as thin as .040" / 1 mm.
- Grade 8 and property class 10.9 studs meeting 150 ksi/1040 MPa minimum.
- Recommended for use in steel or HSLA steel sheets HRB (Rockwell "B" Scale) 89 / HB (Hardness Brinell) 180 or less.
- Large head diameter spreads compressive stress on panel.

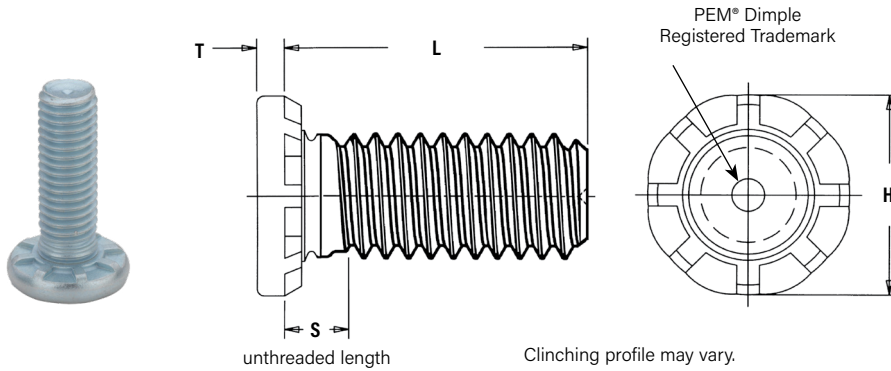

Part Number Designation

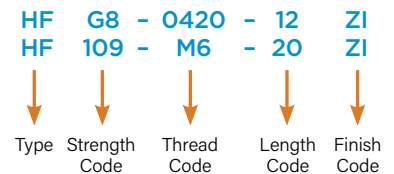

All dimensions are in inches.

Unified	Thread Size	Type	Thread Code	Length Code "L" ±.015 (1) (Length Code in 16ths of an inch)			Min. Sheet Thickness (2)	Hole Size in Sheet +.005 -.000	H ±.01	S Max. (3)	T Max.	Max. Hole in Attached Parts	Min. Dist. Hole C/L to Edge (4)
		Steel											
	.500	.750	1.00										
	.190-32 (#10-32)	HFG8	032	8	12	16	.040	.190	.391	.105	.077	.280	.469
	.250-20 (1/4-20)	HFG8	0420	8	12	16	.040	.250	.507	.125	.090	.340	.709
	.313-18 (5/16-18)	HFG8	0518	—	12	16	.060	.312	.645	.140	.126	.402	.827

Tensile strength: 150 ksi

All dimensions are in millimeters.

Metric	Thread Size x Pitch	Type	Thread Code	Length Code "L" ±0.4 (1) (Length Code in millimeters)			Min. Sheet Thickness (2)	Hole Size in Sheet +0.13	H ±0.25	S Max. (3)	T Max.	Max. Hole in Attached Parts	Min. Dist. Hole C/L to Edge (4)
		Steel											
	M5 x 0.8	HF109	M5	15	20	25	1	5	10.3	2.6	2.06	7.3	11.5
M6 x 1	HF109	M6	15	20	25	1	6	12.1	2.7	2.29	8.3	18.0	
M8 x 1.25	HF109	M8	—	20	25	1.5	8	16.6	3.4	3.25	10.3	21.0	

Tensile strength: 1040 MPa

- (1) Other lengths available up to a maximum of 1.5" (unified) and 40 mm (metric) on special order.
- (2) See page 22 for installation tool requirements.
- (3) Threads are gaugeable to within 2 pitches of the "S" Max. dimension. A class 3B/5H maximum material commercial nut shall pass up to the "S" Max. dimension.
- (4) For more information on proximity to bends and distance to other clinch hardware, see PEM® Tech Sheet C/L To Edge.

To be sure that you are getting genuine PEM products, look for the PEM stamp. Studs within the size range of the SAE and ISO 898-1 and DIN EN ISO 898-1 specs are also identified with the Grade 8 and 10.9 head markings respectively.

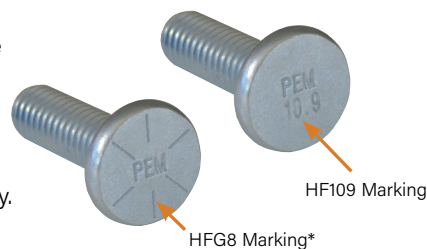

* Thread size #10-32 does not have SAE head marking since it is technically not within the size range of the specification.

HFLH™ Hard Panel Studs

- Installs into thinner, harder, high strength steel materials
- Recommended for use in HSLA sheets up to 700 MPa ultimate (hardness up to 96 HRB) such as s500⁽¹⁾

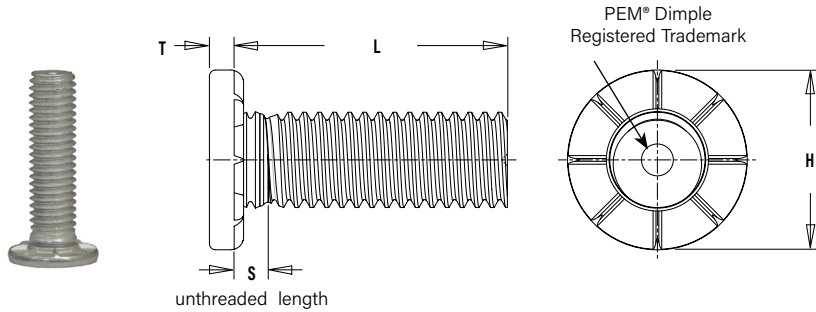

Part Number Designation

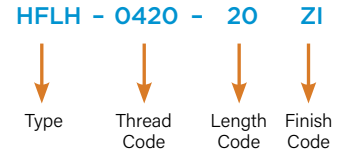

All dimensions are in inches.

Unified	Thread Size	Type	Thread Code	Length Code "L" ±.015 (Length Code in 16ths of an inch)						Min. Sheet Thickness (2)	Hole Size In Sheet +.005 -.000	H ±.01	S Max. (3)	T Max.	Max. Hole in Attached Parts	Min. Dist. Hole C/L to Edge (4)	
		Fastener Material															
	Hardened Alloy Steel																
	.190-32 (#10-32)	HFLH	032	.500	.750	1.00	1.25	1.50	1.75	2.00	.040	.190	.357	.102	.048	.280	.360
	.250-20 (1/4-20)	HFLH	0420	.500	.750	1.00	1.25	1.50	1.75	2.00	.040	.250	.462	.118	.060	.340	.470
	.313-18 (5/16-18)	HFLH	0518	.500	.750	1.00	1.25	1.50	1.75	2.00	.060	.312	.586	.133	.083	.402	.560

Tensile strength: 120 ksi

All dimensions are in millimeters.

Metric	Thread Size x Pitch	Type	Thread Code	Length Code "L" ±.04 (Length Code in millimeters)						Min. Sheet Thickness (2)	Hole Size In Sheet +0.13	H ±0.25	S Max. (3)	T Max.	Max. Hole in Attached Parts	Min. Dist. Hole C/L to Edge (4)	
		Fastener Material															
	Hardened Alloy Steel																
	M5 x 0.8	HFLH	M5	15	20	25	30	35	40	50	1	5	9.6	2.6	1.35	7.3	10
	M6 x 1	HFLH	M6	15	20	25	30	35	40	50	1	6	11.35	2.8	1.52	8.3	11.5
	M8 x 1.25	HFLH	M8	15	20	25	30	35	40	50	1.5	8	15.3	3.3	2.13	10.3	14.5

Tensile strength: 900 MPa

- (1) Material meeting specification DIN EN 10149-2, grade S500MC with minimum yield of 500 MPa and max tensile of 700 MPa is a typical panel material in which type HFLH studs can be used.
- (2) See page 21 for installation tool requirements.
- (3) Threads are gaugeable to within 2 pitches of the "S" Max. dimension. A class 3B/5H maximum material commercial nut shall pass up to the "S" Max. dimension.
- (4) For more information on proximity to bends and distance to other clinch hardware, see [PEM® Tech Sheet C/L To Edge](#).

SGPC™ Swaging Collar Studs

- Installs into sheets as thin as .024" / 0.6 mm.
- Can be used to attach dissimilar materials.
- Can captivate multiple panels as long as the total thickness does not exceed the maximum sheet thickness.⁽¹⁾
- Can be installed into most materials, including stainless steel and rigid non-metallic panels.
- Allows for close centerline-to-edge distance.

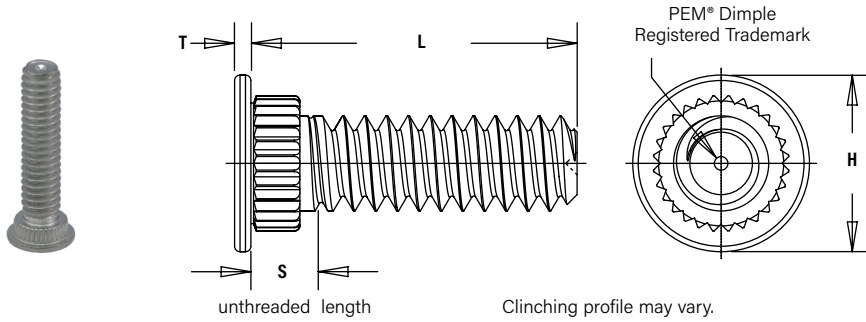

Part Number Designation

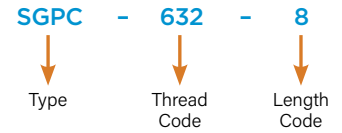

All dimensions are in inches.

Unified	Thread Size	Type	Thread Code	Length Code "L" ±.015 (Length Code in 16ths of an inch)								Sheet Thickness (2)	Hole Size in Sheet +.003 -0.000	H ±.010	S Max. (3)	T ±.004	Hole Dia. of Attached Panel +.005 -0.000	Min. Dist. Hole C/L to Edge (4)
		Fastener Material																
	Stainless Steel	.312	.375	.500	.625	.750	.875	1.00	1.25	1.50								
.086-56 (#2-56)	SGPC	256	5	6	8	10	12	—	—	—	—	.024 - .047	.145	.189	.093	.020	.182	.130
.112-40 (#4-40)	SGPC	440	5	6	8	10	12	14	16	20	—	.024 - .047	.171	.228	.101	.024	.205	.160
.138-32 (#6-32)	SGPC	632	5	6	8	10	12	14	16	20	24	.024 - .047	.196	.256	.109	.024	.229	.180
.164-32 (#8-32)	SGPC	832	5	6	8	10	12	14	16	20	24	.024 - .047	.223	.279	.109	.024	.259	.200
.190-32 (#10-32)	SGPC	032	5	6	8	10	12	14	16	20	24	.024 - .047	.249	.307	.109	.024	.280	.210
.250-20 (1/4-20)	SGPC	0420	—	6	8	10	12	14	16	20	24	.024 - .047	.309	.366	.131	.028	.343	.250

All dimensions are in millimeters.

Metric	Thread Size x Pitch	Type	Thread Code	Length Code "L" ±0.4 (Length Code in millimeters)								Sheet Thickness (2)	Hole Size in Sheet +0.08	H ±0.25	S Max. (3)	T ±0.1	Hole Dia. of Attached Panel +0.13	Min. Dist. Hole C/L to Edge (4)
		Fastener Material																
	Stainless Steel	8	10	12	15	18	—	—	—	—								
M2.5 x 0.45	SGPC	M2.5	8	10	12	15	18	—	—	—	—	0.6 - 1.2	4	5	2.4	0.5	4.95	3.9
M3 x 0.5	SGPC	M3	8	10	12	15	18	20	25	—	—	0.6 - 1.2	4.5	6	2.5	0.6	5.45	4.3
M4 x 0.7	SGPC	M4	8	10	12	15	18	20	25	30	—	0.6 - 1.2	5.5	7	2.7	0.6	6.3	4.9
M5 x 0.8	SGPC	M5	8	10	12	15	18	20	25	30	35	0.6 - 1.2	6.5	8	2.8	0.6	7.45	5.5
M6 x 1	SGPC	M6	—	10	12	15	18	20	25	30	35	0.6 - 1.2	7.5	9	3	0.7	8.3	6.2

- (1) When using the fastener to attach more than one sheet or panel, the stud may seem slightly loose after installation. This is a normal condition in some applications and will not effect the stud's performance.
- (2) See page 23 for installation tooling requirements. Contact Technical Support (techsupport@pemnet.com) for other thicknesses.
- (3) Threads are gaugeable to within 2 pitches on the "S" Max. dimension. A class 3B/5H maximum material commercial nut shall pass up to the "S" Max. dimension.
- (4) For more information on proximity to bends and distance to other clinch hardware, see [PEM® Tech Sheet C/L To Edge](#).

FHX™ Flush-Head Studs With X-Press™ Thread Profile

For Use With Push On Plastic Mating Fasteners

- Offers fast, reliable attachment.
- Coarse thread design of the thread reduces assembly time and provides high retention force.
- Allows for lighter assembly.
- Self-clinching stud mounts flush in metal sheets as thin as 1mm.
- Thread design accommodates paints and coatings without compromising performance.
- Self-clinching technology is cleaner and has a more attractive finished appearance than welding.
- Can be installed during the stamping process with PEMSERTER® in-die technology.

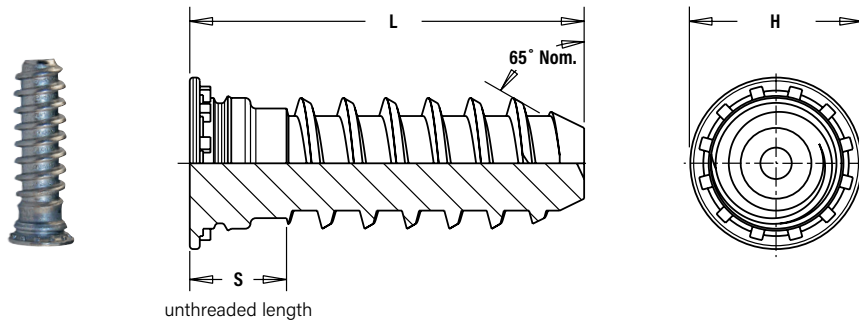

Part Number Designation

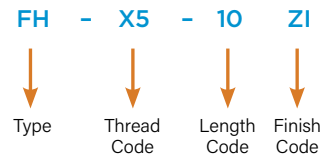

All dimensions are in millimeters.

Thread Size x Pitch	Type	Thread Code	Length Code "L" ±0.4 (Length Code in millimeters)				Min. Sheet Thickness	Hole Size in Sheet +0.08	H ±0.4	S Max.
			10	15	20	25				
5 mm x 1.6	FH	X5	10	15	20	25	1	5.2	6.5	4
6 mm x 1.6	FH	X6	10	15	20	25	1.6	6.2	8.2	4

(1) See page 23 for installation tool requirements.

Examples of plastic nuts and wire tie products that can be used with PEM® X-Press™ studs.



Contact Tech Support for more information.

Press-on (kwik) nut can be used to hold down soft materials such as foam, cloth or insulation.

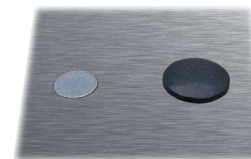

Standard head mounts flush in sheet. Domed head available on special order.

FH™/FHS™/FHA™ Flush-Head Pins

- Flush-head for sheet thickness of .040" / 1 mm and greater.
- FH pins are recommended for use in steel or aluminum sheets HRB (Rockwell "B" Scale) 80 / HB (Hardness Brinell) 150 or less.
- FHS pins are recommended for use in steel or aluminum sheets HRB (Rockwell "B" Scale) 70 / HB (Hardness Brinell) 125 or less.
- FHA pins are recommended for use in aluminum sheets HRB (Rockwell "B" Scale) 50 / HB (Hardness Brinell) 82 or less.

These PEM® pins are only available on special order. See TPS, TP4, and TPXS pins on page 16 for standard diameter pins.

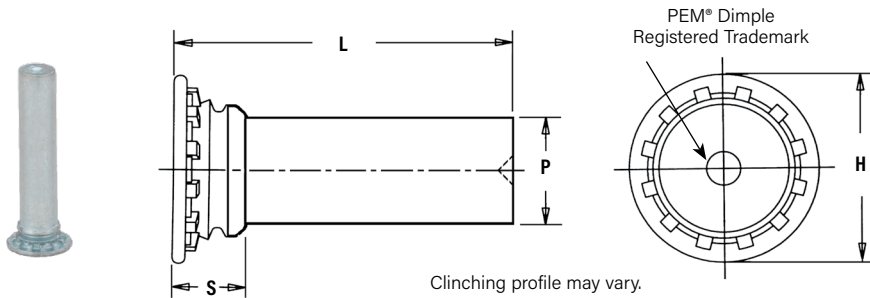

Part Number Designation

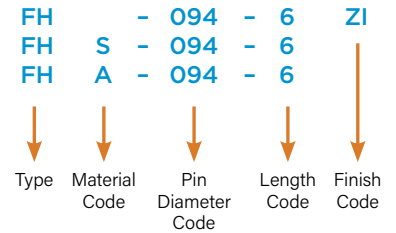

All dimensions are in inches.

Unified	Nominal Pin Diameter P±.002	Type Fastener Material			Pin Dia. Code	Length Code "L" ±.015 (Length Code in 16ths of an inch)										Min. Sheet Thickness (1)	Hole Size in Sheet +.003 -.000	H ± .015	S Max. (2)	Min. Dist. Hole C/L to Edge (3)
		Steel	Stainless Steel	Aluminum		.250	.312	.375	.500	.625	.750	.875	1.00	1.25	1.50					
		FH	FHS	FHA																
.073	FH	FHS	FHA	073	4	5	6	8	10	—	—	—	—	—	.040	.085	.15	.075	.19	
.084	FH	FHS	FHA	084	4	5	6	8	10	12	—	—	—	—	.040	.099	.16	.085	.22	
.094	FH	FHS	FHA	094	4	5	6	8	10	12	—	—	—	—	.040	.111	.18	.085	.22	
.103	FH	FHS	FHA	103	4	5	6	8	10	12	—	—	—	—	.040	.118	.18	.085	.22	
.106	FH	FHS	FHA	106	4	5	6	8	10	12	14	16	20	—	.040	.125	.19	.090	.22	
.116	FH	FHS	FHA	116	4	5	6	8	10	12	14	16	20	—	.040	.137	.21	.090	.25	
.120	FH	FHS	FHA	120	4	5	6	8	10	12	14	16	20	24	.040	.137	.21	.090	.25	
.137	FH	FHS	FHA	137	4	5	6	8	10	12	14	16	20	24	.040	.157	.23	.090	.28	
.141	FH	FHS	FHA	141	4	5	6	8	10	12	14	16	20	24	.040	.163	.24	.090	.28	
.160	FH	FHS	FHA	160	4	5	6	8	10	12	14	16	20	24	.040	.189	.26	.100	.28	
.167	FH	FHS	FHA	167	—	5	6	8	10	12	14	16	20	24	.040	.189	.26	.100	.28	
.173	FH	FHS	FHA	173	—	5	6	8	10	12	14	16	20	24	.040	.197	.26	.100	.28	
.207	FH	FHS	FHA	207	—	5	6	8	10	12	14	16	20	24	.062	.236	.32	.135	.31	
.215	FH	FHS	FHA	215	—	—	—	8	10	12	14	16	20	24	.062	.250	.34	.135	.31	
.223	FH	FHS	FHA	223	—	—	—	8	10	12	14	16	20	24	.062	.250	.34	.135	.31	
.273	FH	FHS	FHA	273	—	—	—	8	10	12	14	16	20	24	.093	.312	.38	.160	.38	
.281	FH	FHS	FHA	281	—	—	—	8	10	12	14	16	20	24	.093	.312	.38	.160	.38	

All dimensions are in millimeters.

Metric	Nominal Pin Diameter P±0.05	Type Fastener Material			Pin Dia. Code	Length Code "L" ±0.4 (Length Code in millimeters)										Min. Sheet Thickness (1)	Hole Size in Sheet +0.08	H ± 0.4	S Max. (2)	Min. Dist. Hole C/L to Edge (3)
		Steel	Stainless Steel	Aluminum		6	8	10	12	15	18	20	25	30	—					
		FH	FHS	FHA																
3	FH	FHS	FHA	3MM	6	8	10	12	15	18	20	25	30	—	1	3.5	5.3	2.3	6.4	
4	FH	FHS	FHA	4MM	—	8	10	12	15	18	20	25	30	35	1	4.1	6	2.3	7.1	
5	FH	FHS	FHA	5MM	—	8	10	12	15	18	20	25	30	35	1	5.5	7.5	2.55	7.6	

- (1) See page 24 for installation tool requirements.
- (2) Pin diameter may exceed max. in this region.
- (3) For more information on proximity to bends and distance to other clinch hardware, see [PEM® Tech Sheet C/L To Edge](#).

TPS™/TP4™ Flush-Head Pilot Pins

- Flush-head for sheet thickness of .040" / 1 mm and greater.
- Satisfies a wide range of positioning, pivot, and alignment applications.
- Chamfered end makes mating hole location easy.
- TPS pins are recommended for use in steel or aluminum sheets HRB (Rockwell "B" Scale) 70 / HB (Hardness Brinell) 125 or less.
- TP4 pins are recommended for use in stainless steel sheets HRB (Rockwell "B" Scale) 92 / HB (Hardness Brinell) 195 or less.

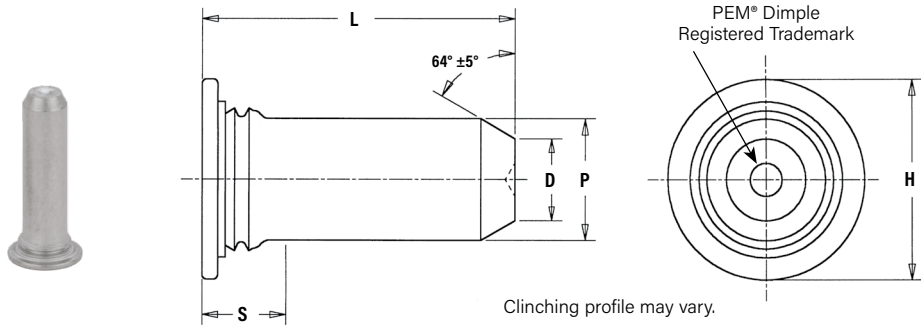

Part Number Designation

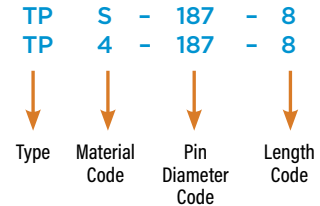

All dimensions are in inches.

Unified	Pin Diameter P ±.002	Type		Pin Diameter Code	Length Code "L" ± .015 (Length Code in 16ths of an inch)					Min. Sheet Thickness (1)	Hole Size in Sheet +.003 -.000	D ±.006	H ±.015	S Max. (2)	Min. Dist. Hole C/L to Edge (3)
		Fastener Material			.375	.500	.625	.750	1.00						
		300 Series Stainless Steel	400 Series Stainless Steel												
	.125	TPS	TP4	125	6	8	10	12	—	.040	.144	.090	.205	.090	.250
	.187	TPS	TP4	187	6	8	10	12	16	.040	.205	.132	.270	.090	.280
	.250	TPS	TP4	250	—	8	10	12	16	.040	.272	.177	.335	.090	.310

All dimensions are in millimeters.

Metric	Pin Diameter P ±0.05	Type		Pin Diameter Code	Length Code "L" ± 0.4 (Length Code in millimeters)					Min. Sheet Thickness (1)	Hole Size in Sheet +0.08	D ±0.15	H ±0.4	S Max. (2)	Min. Dist. Hole C/L to Edge (3)	
		Fastener Material			6	8	10	12	16							—
		300 Series Stainless Steel	400 Series Stainless Steel													
	3	TPS	TP4	3MM	6	8	10	12	16	—	1	3.5	2.11	5.2	2.29	6.4
	4	TPS	TP4	4MM	6	8	10	12	16	—	1	4.5	2.82	6.12	2.29	7.1
	5	TPS	TP4	5MM	—	—	10	12	16	20	1	5.5	3.53	7.19	2.29	7.6
	6	TPS	TP4	6MM	—	—	—	12	16	20	1	6.5	4.24	8.13	2.29	7.9

- (1) See page 25 for installation tool requirements.
- (2) Pin diameter may exceed max. in this region.
- (3) For more information on proximity to bends and distance to other clinch hardware, see [PEM® Tech Sheet C/L To Edge](#).

If your application requires corrosion resistant fasteners, non-magnetic fasteners, or will be exposed to temperatures above 300° F (149° C), see note at bottom of page 6 about "400 series fasteners for stainless steel panels".

TPXS™ Self-Clinching Pilot Pins

- Meets the ATCA PICMG 3.0 specification.
- 15° tapered point makes engaging the mating hole easy.



Min. Sheet Thickness: 1 mm
 Hole Size In Sheet: 3.5 mm +0.08
 Min. Dist. Hole C/L To Edge: 6.4 mm

PEM® Part Number: TPXS-3MM-16

Contact techsupport@pemnet.com for other sizes and materials

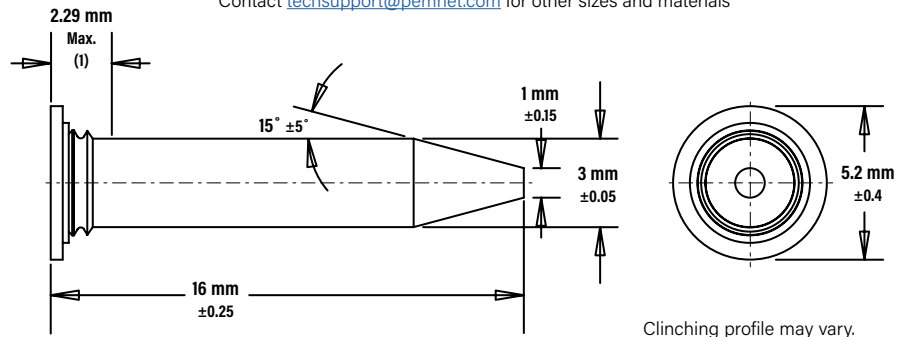

(1) Pin diameter may exceed max. in this region.

Material And Finish Specifications

Type	Threads (1)	Fastener Materials							Standard Finishes			Optional Finishes (2)		
	External, ASME B1.1, 2A / ASME B1.13M, 6g	Hardened Carbon Steel	Hardened Medium Carbon Alloy Steel	Aluminum (plain finish)	CDA 510 Phosphor Bronze	Age Hardened A286 Stainless Steel	300 Series Stainless Steel	400 Series Stainless Steel	No Finish (4)	Zinc plated per ASTM B633, SC1 (5µm), Type III, Colorless, (5)	Passivated and/or Tested Per ASTM A380	Zinc Plated per ASTM B633, SC1 (5µm), Type II, Yellow, (5)	No Finish (4)	Rust Preventative Oil
FH	▪	▪								▪	▪			
FHS	▪						▪				▪			
FHA	▪			▪					▪ (3)					
FH4	▪							▪			▪			
FHP	▪					▪					▪			
FHL	▪	▪								▪	▪			
FHLS	▪						▪				▪			
TFH	▪	▪								▪	▪			
TFHS	▪						▪				▪			
HFE	▪	▪								▪	▪			
THFE	▪	▪								▪	▪			
HFH	▪	▪								▪	▪			
HFHB	▪				▪				▪		▪			
HFHS	▪						▪				▪			
HFG8	▪		▪							▪	▪			
HF109	▪		▪							▪	▪			
HFLH	▪		▪							▪		▪ (6)		
SGPC	▪						▪			▪				
FHX		▪								▪			▪	
TPS							▪				▪			
TP4								▪			▪			
TPXS							▪				▪			
Part Number Codes for Finishes									X	ZI	None	ZC	X	X

Type	For use in Sheet Hardness (7)								
	HRB 50 / HB 82 or Less	HRB 55 / HB 83 or Less	HRB 70 / HB 125 or Less	HRB 80 / HB 150 or Less	HRB 85 / HB 165 or Less	HRB 89 / HB 180 or Less	HRB 92 / HB 195 or Less	HRB 96 / HB 216 or Less	Any Sheet Hardness
FH				▪					
FHS			▪						
FHA	▪								
FH4							▪		
FHP							▪		
FHL				▪					
FHLS			▪						
TFH				▪					
TFHS			▪						
HFE					▪				
THFE					▪				
HFH					▪				
HFHB		▪							
HFHS			▪						
HFG8						▪			
HF109						▪			
HFLH								▪	
SGPC									▪
FHX				▪					
TPS			▪						
TP4							▪		
TPXS			▪						

- (1) For plated studs, Class 2A/6g, the maximum major and pitch diameter, after plating, may equal basic sizes and be gauged to Class 3A/4h. Per ASME B1.1, Section 7, Paragraph 7.2 and ASME B1.13M, Section 8, paragraph 8.2.
- (2) Special order with additional charge.
- (3) Part numbers for aluminum studs have no finish suffix.
- (4) "X" suffix studs may have pitch diameters and major diameters below 2A/6g minimum size, per ANSI B1.1, Section 7, and B1.13M, Section 8 to allow for minimum of 0.0002" / 0.0051 mm of plating.
- (5) See PEM Technical Support section of our web site for related plating standards and specifications.
- (6) With rust preventative oil.
- (7) HRB - Hardness Rockwell "B" Scale. HB - Hardness Brinell.

Installation - FH™/FHS™/FHA™ Threaded Studs

1. Prepare properly sized mounting hole in sheet. Do not perform any secondary operations such as deburring.
2. Insert stud through mounting hole (punch side) of sheet and into anvil hole.
3. With punch and anvil surfaces parallel, apply squeezing force to embed the head of the stud flush in the sheet. In most cases, when using sheets .060"/1.51 mm and thicker, the anvil requires only a straight thru hole to accommodate the stud. For sheets less than .060/1.51 mm, the hole requires a countersink for metal flow around the shank of the stud.

Tooling for sheet thicknesses less than .060 / 1.51 mm with #2 thru #10 / M2.5 thru M5 thread sizes and less than .093" / 2.36 mm for 1/4" / M6 threads.

Tooling for sheet thicknesses .060" / 1.51 mm and greater with #2 thru #10 / M2.5 thru M5 thread sizes and .093" / 2.36 mm and greater for 1/4" and 5/16" / M6 and M8 threads.

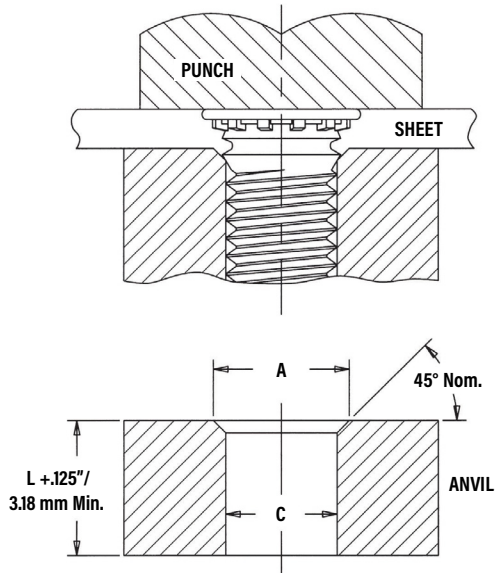

See page 5 for "L."

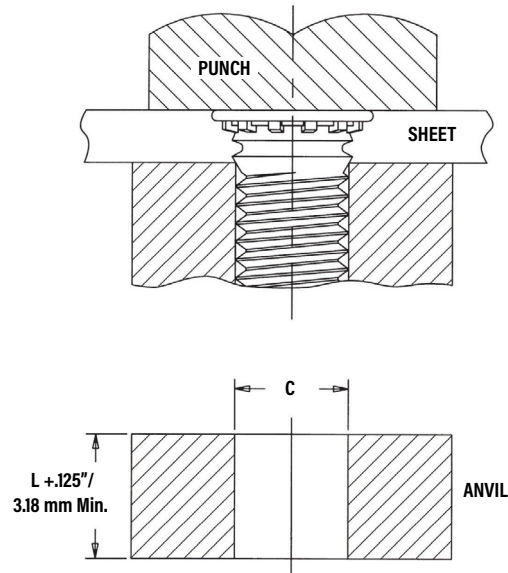

Installation Tooling

Unified	Thread Code	HAEGER® Part No.			PEMSERTER® Part No.			Anvil Dimensions (in.)	
		Anvil for Sheets > .060"	Anvil for Sheets ≤ .059"	Punch	Anvil for Sheets > .060"	Anvil for Sheets ≤ .059"	Punch	A	C
	256	H-103-2L	H-103-2LC	H-108-0020L	970200005300	970200240300	975200048	.110 - .114	.087 - .090
440	H-103-4L	H-103-4LC	H-108-0020L	970200006300	970200241300	975200048	.136 - .140	.113 - .116	
632	H-103-6L	H-103-6LC	H-108-0020L	970200007300	970200243300	975200048	.162 - .166	.139 - .142	
832	H-103-8L	H-103-8LC	H-108-0020L	970200008300	970200245300	975200048	.188 - .192	.165 - .168	
024/032	H-103-10L	H-103-10LC	H-108-0020L	970200009300	970200246300	975200048	.216 - .220	.191 - .194	
		Anvil for Sheets > .093"	Anvil for Sheets ≤ .092"		Anvil for Sheets > .093"	Anvil for Sheets ≤ .092"			
0420	H-103-04L	H-103-04LC	H-108-0020L	970200010300	970200249300	975200048	.295 - .300	.250 - .253	
0518	H-103-05L	H-103-05LC	H-108-0020L	970200011300	—	975200048	—	.3125 - .3155	

Metric	Thread Code	HAEGER® Part No.			PEMSERTER® Part No.			Anvil Dimensions (mm)	
		Anvil for Sheets > 1.51mm	Anvil for Sheets ≤ 1.51mm	Punch	Anvil for Sheets > 1.51mm	Anvil for Sheets ≤ 1.51mm	Punch	A + 0.1	C + 0.08
	M2.5	H-103-M2.5L	H-103-M2.5LC	H-108-0020L	970200300300	970200493300	975200048	3.1	2.53
M3	H-103-M3L	H-103-M3LC	H-108-0020L	970200229300	970200242300	975200048	3.6	3.03	
M3.5	H-103-M3.5L	H-103-M3.5LC	H-108-0020L	970200007300	970200243300	975200048	4.1	3.53	
M4	H-103-M4L	H-103-M4LC	H-108-0020L	970200019300	970200244300	975200048	4.6	4.03	
M5	H-103-M5L	H-103-M5LC	H-108-0020L	970200020300	970200247300	975200048	5.6	5.03	
		Anvil for Sheets > 2.36mm	Anvil for Sheets ≤ 2.36mm		Anvil for Sheets > 2.36mm	Anvil for Sheets ≤ 2.36mm			
M6	H-103-M6L	H-103-M6LC	H-108-0020L	970200230300	970200248300	975200048	6.6	6.03	
M8	H-103-M8L	H-103-M8LC	H-108-0020L	970200231300	—	975200048	—	8.03	

Installation - FH4™/FHP™ Studs For Stainless Steel Sheets

1. Prepare properly sized mounting hole in sheet. Do not perform any secondary operations such as deburring.
2. Insert stud through mounting hole (punch side) of sheet and into anvil hole.
3. With punch and anvil surfaces parallel, apply squeezing force to embed the head of the stud flush in the sheet.

For FH4/FHP studs, a special anvil with a raised ring is required to create a proper installation. The raised ring acts as a second displacer of the stainless sheet material, thereby ensuring that the annular groove is filled. Please see page 6 for recommended sheet thickness range.

The special anvils are available from PEM stock or can be machined from suitable tool steel. A hardness of HRC 55 / HB 547 minimum is required to provide long anvil life. We recommend measuring the "P" dimension every 5000 installations to ensure that the anvil remains within specification.

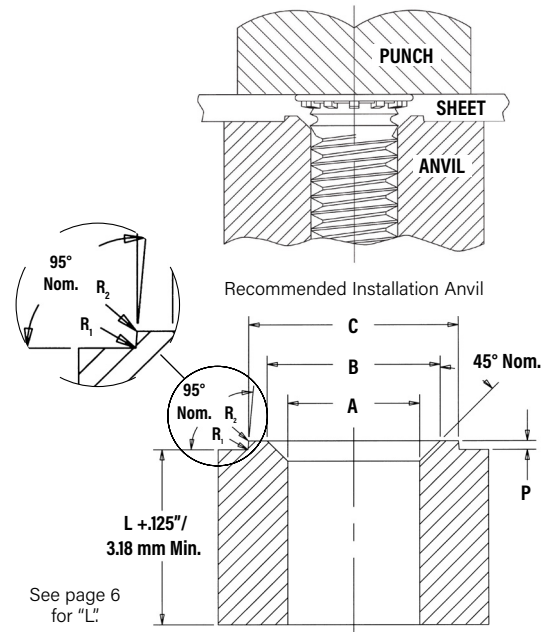

Installation Tooling

Unified	Thread Code	HAEGER® Part Number		PEMSERTER® Part Number		Anvil Dimensions (in.)					
		Anvil	Punch	Anvil	Punch	A +0.003 -0.000	B ±0.002	C ±0.002	P ±0.001	R1 Max.	R2 Max.
	440	H-181-4L	H-108-0020L	8001645	975200048	.113	.144	.174	.101	.003	.005
632	H-181-6L	H-108-0020L	8001644	975200048	.140	.170	.200	.100	.003	.005	
832	H-181-8L	H-108-0020L	8001643	975200048	.166	.202	.236	.100	.003	.005	
032	H-181-10L	H-108-0020L	8001642	975200048	.191	.235	.275	.100	.003	.005	
0420	H-181-04L	H-108-0020L	8002535	975200048	.252	.324	.360	.020	.003	.005	

Metric	Thread Code	HAEGER® Part Number		PEMSERTER® Part Number		Anvil Dimensions (mm)					
		Anvil	Punch	Anvil	Punch	A ±0.08	B ±0.05	C ±0.05	P ±0.025	R1 Max.	R2 Max.
	M3	H-181-M3L	H-108-0020L	8001678	975200048	3.05	3.81	4.57	0.25	0.08	0.13
M4	H-181-M4L	H-108-0020L	8001677	975200048	4.04	4.95	5.82	0.25	0.08	0.13	
M5	H-181-M5L	H-108-0020L	8001676	975200048	5.08	6.15	7.16	0.25	0.08	0.13	
M6	H-181-M6L	H-108-0020L	8002536	975200048	6.05	7.87	8.79	0.51	0.08	0.13	

Installation - FHL™/FHLS™ Studs

1. Prepare properly sized mounting hole in sheet. Do not perform any secondary operations such as deburring.
2. Insert stud through mounting hole (punch side) of sheet and into anvil hole.
3. With punch and anvil surfaces parallel, apply squeezing force to embed the head of the stud flush in the sheet. For sheets .060" / 1.51 mm and thicker, the anvil requires only a straight thru hole to accommodate the stud. For sheets less than .060" / 1.51 mm, the hole requires a countersink with dimension A at the top to provide for metal flow around the shank of the stud.

Tooling for sheet thicknesses less than .060" / 1.51 mm.

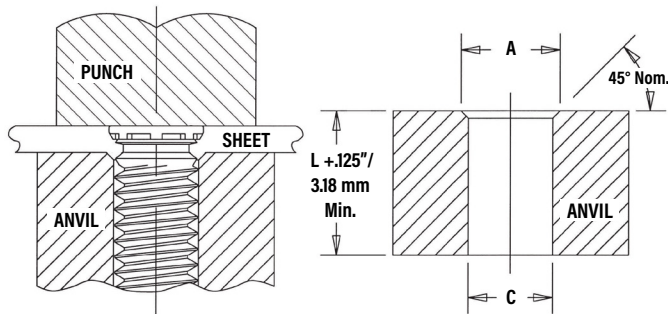

See page 7 for "L"

Tooling for sheet thicknesses .060" / 1.51 mm and greater.

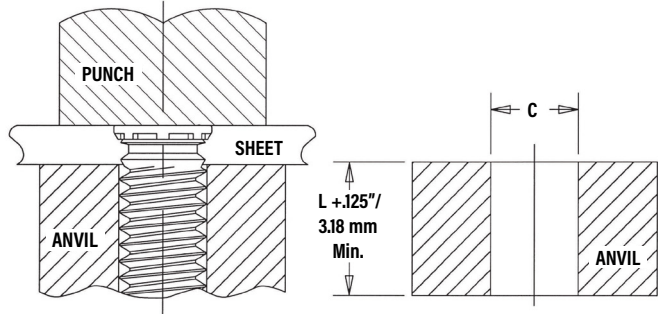

See page 7 for "L"

Installation Tooling

UNIFIED	Thread Code	HAEGER® Part No.			PEMSERTER® Part No.			Anvil Dimensions (in.)	
		Anvil for Sheets > .060"	Anvil for Sheets ≤ .059"	Punch	Anvil for Sheets > .060"	Anvil for Sheets ≤ .059"	Punch	A	C
	256	H-103-2L	H-103-2LC	H-108-0020L	8003313	8003297	975200997	.110 - .114	.087 - .090
440	H-103-4L	H-103-4LC	H-108-0020L	8003618	8003298	975200997	.136 - .140	.113 - .116	
632	H-103-6L	H-103-6LC	H-108-0020L	8003314	8003299	975200997	.162 - .166	.139 - .142	
832	H-103-8L	H-103-8LC	H-108-0020L	8003315	8003300	975200997	.188 - .192	.165 - .168	
032	H-103-10L	H-103-10LC	H-108-0020L	8003619	8003301	975200997	.216 - .220	.191 - .194	

Metric	Thread Code	HAEGER® Part No.			PEMSERTER® Part No.			Anvil Dimensions (mm)	
		Anvil for Sheets > 1.51mm	Anvil for Sheets ≤ 1.5mm	Punch	Anvil for Sheets > 1.51mm	Anvil for Sheets ≤ 1.5mm	Punch	A ±0.05	C ±0.08
	M2.5	H-103-M2.5L	H-103-M2.5LC	H-108-0020L	8003316	8003302	975200997	3.1	2.53
M3	H-103-M3L	H-103-M3LC	H-108-0020L	8003317	8003303	975200997	3.6	3.03	
M3.5	H-103-M3.5L	H-103-M3.5LC	H-108-0020L	8003318	8003304	975200997	4.1	3.53	
M4	H-103-M4L	H-103-M4LC	H-108-0020L	8003620	8003305	975200997	4.6	4.03	
M5	H-103-M5L	H-103-M5LC	H-108-0020L	8003319	8003306	975200997	5.6	5.03	

Installation - TFH™/TFHS™ Non-Flush Studs

1. Prepare properly sized mounting hole in sheet. Do not perform any secondary operations such as deburring.
2. Insert stud through mounting hole (punch side) of sheet and into anvil hole.
3. With punch and anvil surfaces parallel, apply squeezing force until the punch contacts the sheet. When installed, the stud head is not flush but will protrude approximately .025" / 0.64 mm. For sheets .030" / 0.76 mm and thicker, the anvil requires only a straight thru hole to accommodate the stud. For sheets less than .030" / 0.76 mm down to .020" / 0.51 mm, the hole requires a countersink with dimension A at the top to provide for metal flow around the shank of the stud. The standard punch design below provides clearance for the stud head and reduces chances of over squeezing the head of the stud into the sheet metal.

Tooling for sheet thicknesses less than .030" / 0.76 mm down to .020" / 0.51 mm.

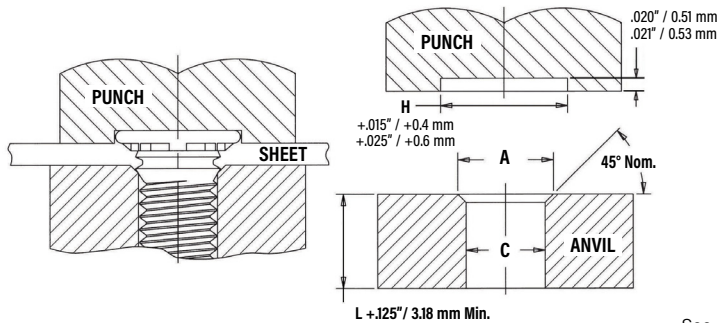

Tooling for sheet thicknesses .030" / 0.76 mm and greater.

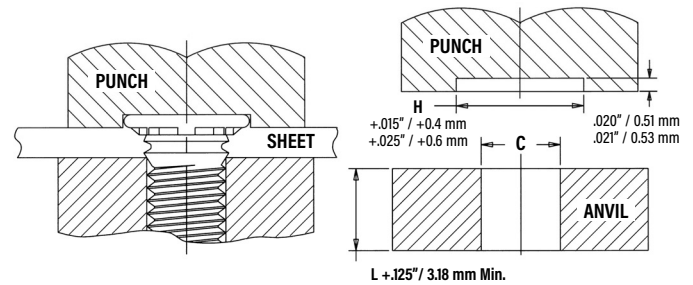

See page 8 for "L"

Installation Tooling

Unified	Thread Code	HAEGER® Part No.			PEMSERTER® Part No.			Anvil Dimension (in.)	
		Anvil for Sheets > .030"	Anvil for Sheets .020" to .029"	Punch (1)	Anvil for Sheets > .030"	Anvil for Sheets .020" to .029"	Punch	A	C
	256	H-103-2L	H-103-2LC	H-108-0020L	970200005300	970200240300	970200235400	.110 - .114	.087 - .090
	440	H-103-4L	H-103-4LC	H-108-0020L	970200006300	970200241300	970200236400	.136 - .140	.113 - .116
	632	H-103-6L	H-103-6LC	H-108-0020L	970200007300	970200243300	970200237400	.162 - .166	.139 - .142
	832	H-103-8L	H-103-8LC	H-108-0020L	970200008300	970200245300	970200238400	.188 - .192	.165 - .168
	032	H-103-10L	H-103-10LC	H-108-0020L	970200009300	970200246300	970200239400	.216 - .220	.191 - .194
	0420	H-103-04L	H-103-04LC	H-108-0020L	970200010300	970200249300	970200496400	.295 - .300	.250 - .253

Metric	Thread Code	HAEGER® Part No.			PEMSERTER® Part No.			Anvil Dimensions (mm)	
		Anvil for Sheets > 0.76mm	Anvil for Sheets 0.51mm to 0.75mm	Punch (1)	Anvil for Sheets > 0.76mm	Anvil for Sheets 0.51mm to 0.75mm	Punch	A +0.1	C +0.08
	M3	H-103-M3L	H-103-M3LC	H-108-0020L	970200229300	970200242300	970200236400	3.6	3.03
	M3.5	H-103-M3.5L	H-103-M3.5LC	H-108-0020L	970200007300	970200243300	970200237400	4.1	3.53
	M4	H-103-M4L	H-103-M4LC	H-108-0020L	970200019300	970200244300	970200238400	4.6	4.03
	M5	H-103-M5L	H-103-M5LC	H-108-0020L	970200020300	970200247300	970200239400	5.6	5.03
	M6	H-103-M6L	H-103-M6LC	H-108-0020L	970200230300	970200248300	970200496400	6.6	6.03

(1) Flat punch. Pocket punch available on special order.

Installation - HFH™/HFHB™/HFHS™ Studs

1. Prepare properly sized mounting hole in sheet. Do not perform any secondary operations such as deburring.
2. Insert stud through mounting hole (punch side) of sheet and into anvil hole.
3. With punch and anvil surfaces parallel, apply squeezing force on the punch sufficient only to embed the ribs on the head of the stud into the sheet.

- .035" - .036" (032)
- .045" - .046" (0420)
- .063" - .064" (0518)
- .077" - .078" (0616)
- 0.94 mm - 0.96 mm (M5)
- 1.14 mm - 1.16 mm (M6)
- 1.62 mm - 1.64 mm (M8)
- 2.1 mm - 2.12 mm (M10)

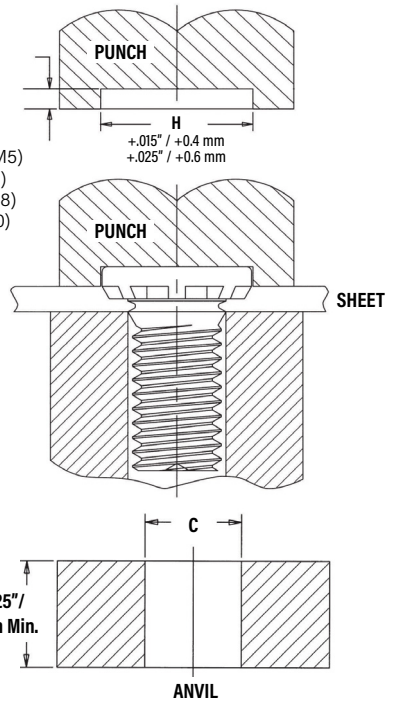

See page 9 for "L."

Installation Tooling

Unified	Thread Code	HAEGER® Part No.		PEMSERTER® Part No.		Anvil Dimensions (in.) C
		Anvil	Punch	Anvil	Punch	
	032	H-103-10L	H-184-10L	970200009300	970200311400	.191 - .194
	0420	H-103-04L	H-184-04L	970200010300	970200312400	.250 - .253
	0518	H-103-05L	H-184-05L	970200011300	970200313400	.3125 - .3155
	0616	H-103-06L	H-184-06L	970200004300	970200314400	.375 - .378

Metric	Thread Code	HAEGER® Part No.		PEMSERTER® Part No.		Anvil Dimensions (mm) C +0.08
		Anvil	Punch	Anvil	Punch	
	M5	H-103-M5L	H-184-10L	970200020300	970200311400	5.03
	M6	H-103-M6L	H-184-04L	970200230300	970200312400	6.03
	M8	H-103-M8L	H-184-05L	970200231300	970200313400	8.03
	M10	H-103-M10L	H-184-M10L	970200402300	970200491400	10.03

Installation - HFE™/THFE™/HFLH™ Studs

HFE™/HFLH™ Studs

1. Prepare properly sized mounting hole in sheet. Do not perform any secondary operations such as deburring.
2. Insert stud through mounting hole (punch side) of sheet and into anvil hole.
3. With punch and anvil surfaces parallel, apply squeezing force on the punch sufficient only to embed the ribs on the head of the stud into the sheet.

Tooling for sheet thicknesses less than .060" / 1.51 mm with #10 / M5 and 1/4" / M6 thread sizes and less than .075" / 1.9 mm with 5/16" / M8 threads.

Tooling for sheet thicknesses .060" / 1.51 mm and greater with #10 / M5 and 1/4" / M6 thread sizes and .075" / 1.9 mm and greater with 5/16" / M8 threads.

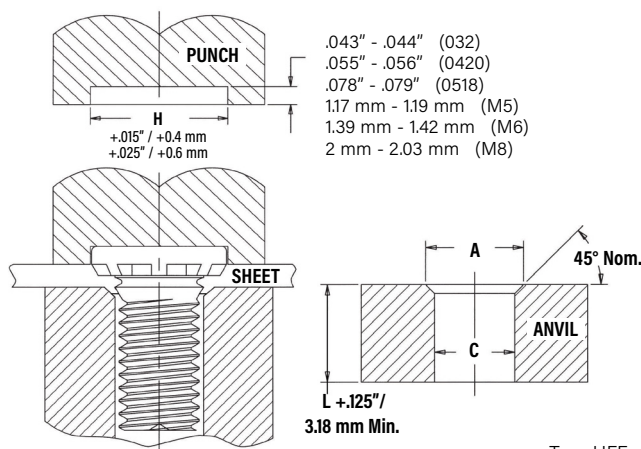

Type HFE see page 10 for "L."
Type HFLH see page 12 for "L."

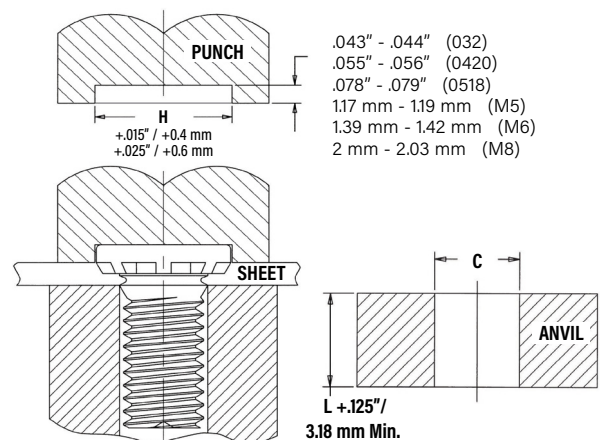

Installation Tooling - HFE™/HFLH™ Studs

Unified	Thread Code	HAEGER® Part No.			PEMSERTER® Part No.			Anvil Dimensions (in.)	
		Anvil for Sheets > .060"	Anvil for Sheets .040" - .060"	Punch (1)	Anvil for Sheets > .060"	Anvil for Sheets .040" - .060"	Punch	A	C
	032	H-103-10L	H-103-10LC	H-108-0020L	970200009300	970200246300	8003707	.216 - .220	.191 - .194
0420	H-103-04L	H-103-04LC	H-108-0020L	970200010300	8003702	8003708	.295 - .300	.250 - .253	
	Anvil for Sheets > .075"	Anvil for Sheets .060" - .075"		Anvil for Sheets > .075"	Anvil for Sheets .060" - .075"				
0518	H-103-05L	H-103-05LC	H-108-0020L	970200011300	8003703	8003709	.334 - .338	.3125 - .3155	

Metric	Thread Code	HAEGER® Part No.			PEMSERTER® Part No.			Anvil Dimensions (mm)	
		Anvil for Sheets > 1.51 mm	Anvil for Sheets 1 mm - 1.51 mm	Punch (1)	Anvil for Sheets > 1.51 mm	Anvil for Sheets 1 mm - 1.51 mm	Punch	A +0.1	C +0.08
	M5	H-103-M5L	H-103-M5LC	H-108-0020L	970200020300	8003704	8003710	5.6	5.03
M6	H-103-M6L	H-103-M6LC	H-108-0020L	970200230300	8003705	8003711	6.6	6.03	
	Anvil for Sheets > 1.9 mm	Anvil for Sheets 1.5 mm - 1.9 mm		Anvil for Sheets > 1.9 mm	Anvil for Sheets 1.5 mm - 1.9 mm				
M8	H-103-M8L	H-103-M8LC	H-108-0020L	970200231300	8003706	8003712	8.6	8.03	

(1) Flat punch. [Pocket punch](#) available on special order.

THFE™ Studs

Tooling for sheet thicknesses less than .052" / 1.31 mm with 1/4" / M6 thread sizes, and less than .067" / 1.71 mm with 5/16" / M8 thread sizes.

Tooling for sheet thicknesses .052" / 1.31 mm and greater with 1/4" / M6 and .067" / 1.71 mm thread sizes and greater with 5/16" / M8 threads.

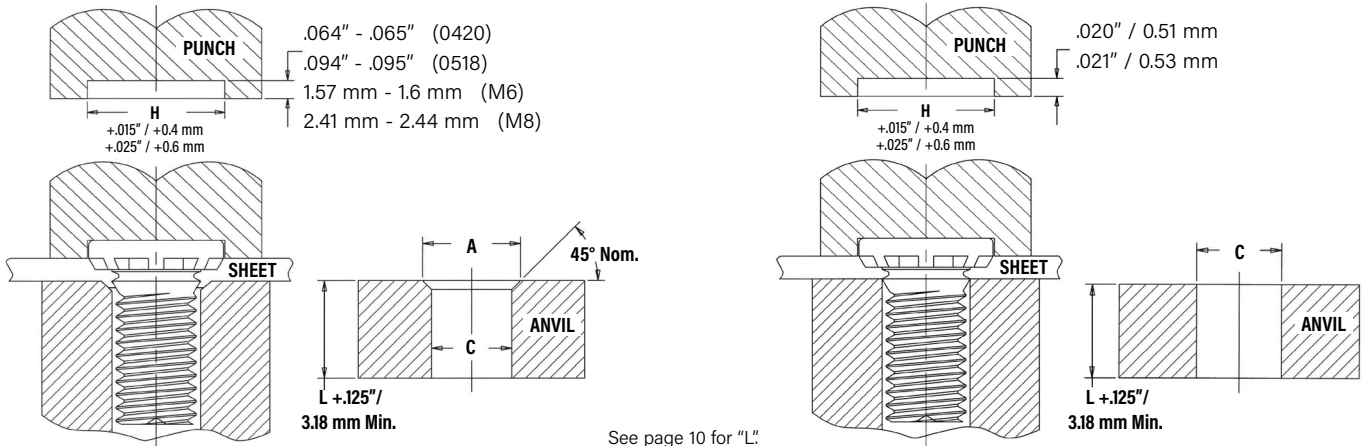

See page 10 for "L."

Installation Tooling

Unified	Thread Code	HAEGER® Part No.			PEMSERTER® Part No.			Anvil Dimensions (in.)	
		Anvil for Sheets > .051"	Anvil for Sheets .031" - .051"	Punch (1)	Anvil for Sheets > .051"	Anvil for Sheets .031" - .051"	Punch	A	C
	0420	H-103-04L	H-103-04LC	H-108-0020L	970200010300	8019886	8019890	.302 - .306	.250 - .253
	Anvil for Sheets > .066"	Anvil for Sheets .031" - .066"		Anvil for Sheets > .066"	Anvil for Sheets .031" - .066"				
0518	H-103-05L	H-103-05LC	H-108-0020L	970200011300	8019887	8019891	.374 - .378	.3125 - .3155	

Metric	Thread Code	HAEGER® Part No.			PEMSERTER® Part No.			Anvil Dimensions (mm)	
		Anvil for Sheets > 1.3 mm	Anvil for Sheets 0.8 mm - 1.3 mm	Punch (1)	Anvil for Sheets > 1.3 mm	Anvil for Sheets 0.8 mm - 1.3 mm	Punch	A +0.1	C + 0.08
	M6	H-103-M6L	H-103-M6LC	H-108-0020L	970200230300	8019888	8019892	7.25	6.03
	Anvil for Sheets > 1.7 mm	Anvil for Sheets 0.08 mm - 1.7 mm		Anvil for Sheets > 1.7 mm	Anvil for Sheets 0.08 mm - 1.7 mm				
M8	H-103-M8L	H-103-M8LC	H-108-0020L	970200231300	8019889	8019893	9.55	8.03	

(1) Flat punch. [Pocket punch](#) available on special order.

Installation - HFG8™/HF109™ Studs

1. Prepare properly sized mounting hole in sheet. Do not perform any secondary operations such as deburring.
2. Insert stud through mounting hole (punch side) of sheet and into anvil hole.
3. With punch and anvil surfaces parallel, apply squeezing force on the punch sufficient only to embed the ribs on the head of the stud into the sheet. Note that for sheets .060" / 1.51 mm and thicker, the anvil requires only a straight thru hole to accommodate the stud. For sheets less than .060" / 1.51 mm to less than .075" / 1.9 mm, the hole requires a countersink with dimension A at the top to provide for metal flow around the shank of the stud.

Tooling for sheet thicknesses less than .060" / 1.51 mm with #10 / M5 and 1/4" / M6 thread sizes and less than .075" / 1.9 mm with 5/16" / M8 threads.

Tooling for sheet thicknesses .060" / 1.51 mm and greater with #10 / M5 and 1/4" / M6 thread sizes and .075" / 1.9 mm and greater with 5/16" / M8 threads.

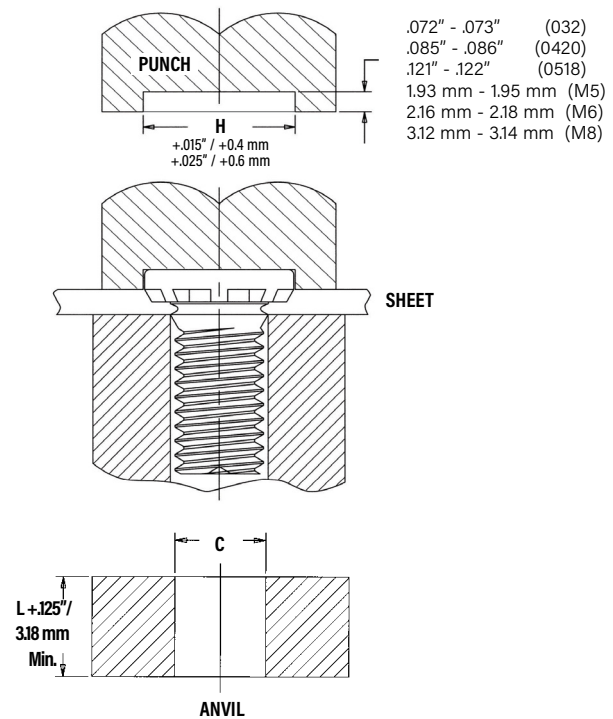
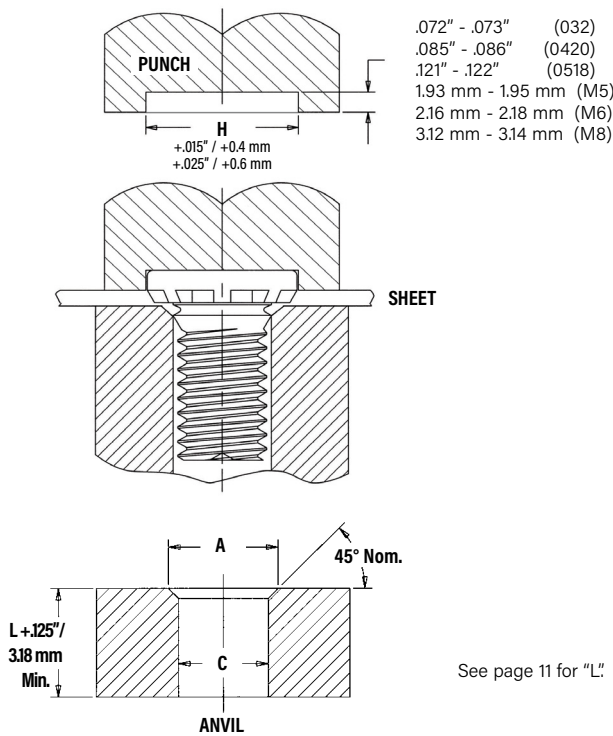

PEMSERTER® Installation Tooling

Unified	Thread Code	HAEGER® Part No.			PEMSERTER® Part No.			Anvil Dimensions (in.)	
		Anvil (Standard Sheets)	Anvil (Thin Sheets)	Punch (1)	Anvil (Standard Sheets)	Anvil (Thin Sheets)	Punch	A	C
	032	H-103-10L	H-103-10LC	H-108-0020L	970200009300	970200246300	8014456	.216 - .220	.191 - .194
0420	H-103-04L	H-103-04LC	H-108-0020L	8021609	8021613	8014458	.273 - .278	.250 - .253	
0518	H-103-05L	H-103-05LC	H-108-0020L	8021610	8021614	8014460	.334 - .338	.3125 - .3155	

Metric	Thread Code	HAEGER® Part No.			PEMSERTER® Part No.			Anvil Dimensions (mm)	
		Anvil (Standard Sheets)	Anvil (Thin Sheets)	Punch (1)	Anvil (Standard Sheets)	Anvil (Thin Sheets)	Punch	A +0.1	C +0.08
	M5	H-103-M5L	H-103-M5LC	H-108-0020L	970200020300	8003704	8014457	5.6	5.03
M6	H-103-M6L	H-103-M6LC	H-108-0020L	8021611	8021615	8014459	6.6	6.03	
M8	H-103-M8L	H-103-M8LC	H-108-0020L	8021612	8021616	8014461	8.6	8.03	

(1) Flat punch. [Pocket punch](#) available on special order.

Installation - SGPC™ Swaging Collar Studs

1. Prepare properly sized mounting hole in sheet.
2. Insert fastener through mounting hole (punch side) as shown in drawing.
3. With installation punch and anvil surfaces parallel, apply squeezing force until the punch pushes over the protruding knurls of the stud.

Installation Tooling

Unified	Thread Code	Punch Dimensions (in.)		Punch Part Number ⁽¹⁾	Anvil Dimensions (in.)		Anvil Part Number ⁽¹⁾
		A +.004 -.000	B +.000 -.001	PEMSERTER®	C +.001	P +.000 -.002	PEMSERTER®
	256	.209	.019	8015111	.087	.014	8016983
440	.248	.022	8015112	.113	.014	8016984	
632	.276	.022	8015113	.139	.014	8016985	
832	.299	.022	8015114	.165	.014	8016986	
032	.327	.022	8015115	.191	.014	8016987	
0420	.386	.026	8015116	.251	.014	8016988	

Metric	Thread Code	Punch Dimensions (mm)		Punch Part Number ⁽¹⁾	Anvil Dimensions (mm)		Anvil Part Number ⁽¹⁾
		A +0.1	B -0.025	PEMSERTER®	C +0.025	P -0.05	PEMSERTER®
	M2.5	5.5	0.47	8015117	2.53	0.35	8016989
M3	6.5	0.57	8015118	3.03	0.35	8016990	
M4	7.5	0.57	8015119	4.03	0.35	8016991	
M5	8.5	0.57	8015120	5.03	0.35	8016992	
M6	9.5	0.67	8015121	6.03	0.35	8016993	

(1) [Click here](#) for a quote on Haeger® custom installation tooling.

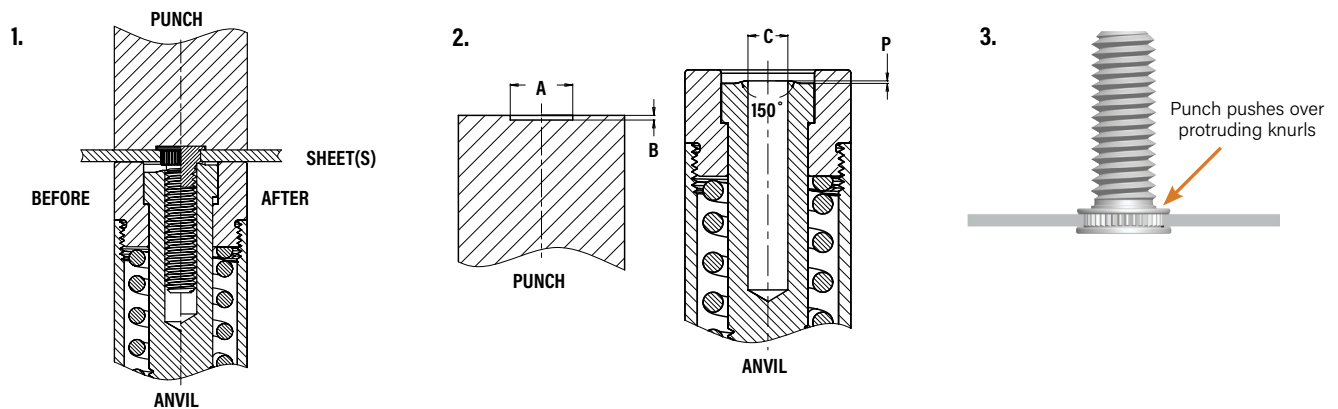

Installation - FHX™ Studs

1. Prepare properly sized mounting hole in sheet. Do not perform any secondary operations such as deburring.
2. Insert stud through mounting hole (punch side) of sheet and into anvil hole.
3. With punch and anvil surfaces parallel, apply squeezing force to embed the head of the stud flush in the sheet. In most cases, when using sheets 1.51 mm and thicker, the anvil requires only a straight thru hole to accommodate the stud (see illustrations below for details). For sheets less than 1.51 mm, the hole requires a countersink with dimension A at the top to provide for metal flow around the shank of the stud.

Tooling for sheet thicknesses less than 1.51 mm with 5 mm thread size and less than 2.4 mm for 6 mm thread size.

Tooling for sheet thicknesses 1.51 mm and greater with 5 mm thread size and 2.4 mm and greater for 6 mm thread size.

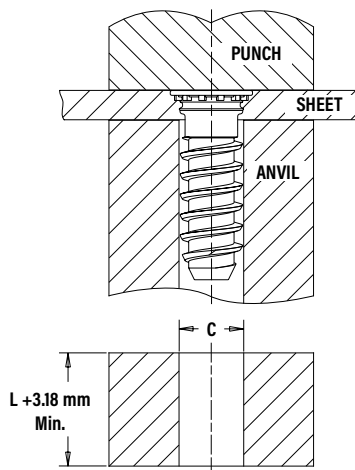
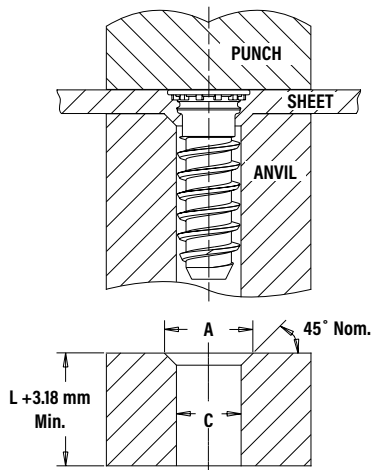

See page 14 for "L."

Installation Tooling

Metric	Thread Code	PEMSERTER® Part No. (1)			Anvil Dimensions (mm)	
		Anvil for Sheets < 1.51	Anvil for Sheets ≥ 1.51	Punch Part Number	A	C
	X5	8021189	8021188	975200048	6.12 - 6.22	5.23 - 5.31
			< 2.4	≥ 2.4		
	X6	8021191	8021190	975200048	7.04 - 7.14	6.25 - 6.33

(1) [Click here](#) for a quote on Haeger® custom installation tooling.

Installation - FH™/FHS™/FHA™ Pins

1. Prepare properly sized mounting hole in sheet. Do not perform any secondary operations such as deburring.
2. Insert pin through mounting hole (punch side) of sheet and into anvil hole.
3. With punch and anvil surfaces parallel, apply squeezing force to embed the head of the pin flush in the sheet. In most cases, when using sheets .060" / 1.51 mm and thicker, the anvil requires only a straight thru hole to accommodate the pin (see illustrations below for details). For sheets less than .060" / 1.51 mm, the hole requires a countersink with dimension A at the top to provide for metal flow around the shank of the pin.

Tooling for sheet thicknesses less than .060" / 1.51 mm with 073 thru 173 / 3 mm thru 5 mm pin diameter codes and for sheet thicknesses less than .093" / 2.36 mm with 207 thru 223 pin diameter codes.

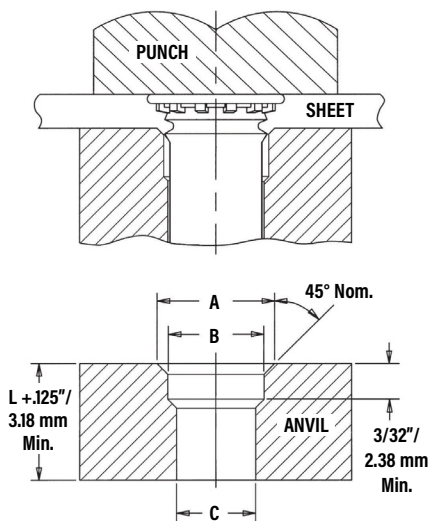

Tooling for sheet thicknesses greater than .060" / 1.51 mm with 073 thru 173 / 3 mm thru 5 mm pin diameter codes and for sheet thicknesses greater than .093" / 2.36 mm with 207 thru 281 pin diameter codes.

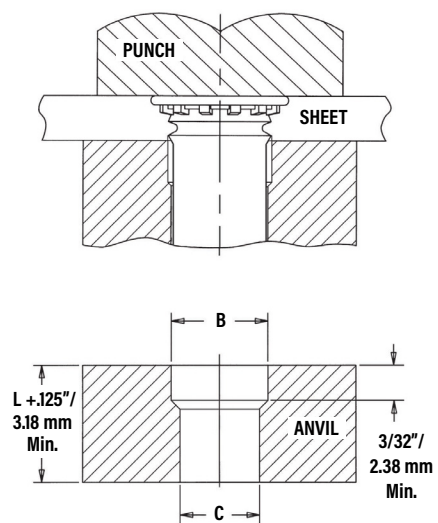

See page 15 for "L"

Installation Tooling

Unified	Pin Dia. Code	Anvil Dimensions (in.)		
		A +.004 -.000	B ±.002	C ±.002
	073	.116	.089	.078
084	.133	.103	.089	
094	.162	.115	.099	
103	.166	.122	.109	
106	.168	.129	.111	
116	.191	.141	.121	
120	.191	.141	.125	
137	.215	.161	.144	
141	.216	.167	.147	
160	.244	.193	.166	
167	.244	.193	.172	
173	.250	.201	.180	
207	.286	.240	.213	
215	.290	.254	.221	
223	.298	.254	.228	
273	.325	.316	.277	
281	.320	.316	.290	

Metric	Pin Dia. Code	Anvil Dimensions (mm)		
		A +0.1	B ±0.05	C ±0.05
3MM	4.9	3.61	3.1	
4MM	5.44	4.19	4.1	
5MM	6.93	5.61	5.1	

Installation - TPS™/TP4™/TPXS™ Pilot Pins

1. Prepare properly sized mounting hole in sheet. Do not perform any secondary operations such as deburring.
2. Insert pin through mounting hole (punch side) of sheet and into anvil hole.
3. With punch and anvil surfaces parallel, apply squeezing force to embed the head of the pin flush in the sheet.

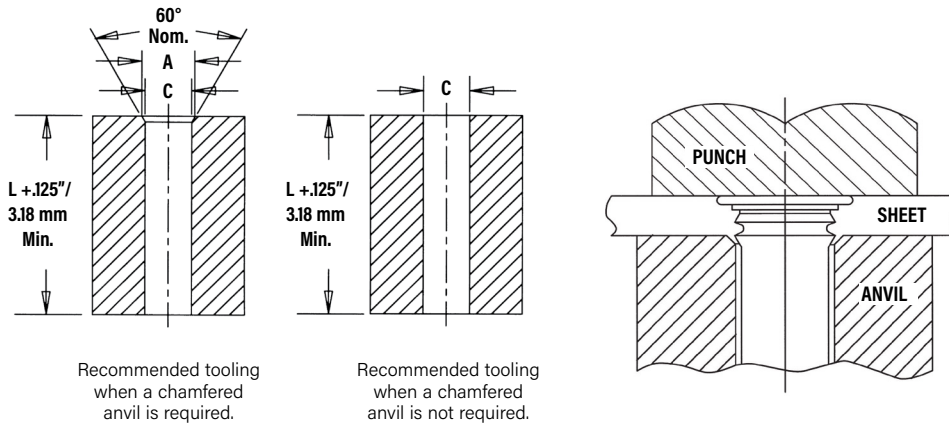

Installation Tooling

Unified	Pin Dia. Code	Test Sheet Thickness (in.)	Anvil Dimensions (in.)		HAEGER® Part Number		PEMSERTER® Part Number	
			A ±.002	C ±.002	Anvil	Punch	Anvil	Punch
	125	.040 - .060	.160	.130	H-106-125L-C	H-108-0020L	8003284	975200048
Over .060		(1)	H-106-125L		H-108-0020L	8003278	975200048	
187	.040 - .065	.220	.192	H-106-187L-C	H-108-0020L	8003285	975200048	
	Over .065	(1)		H-106-187L	H-108-0020L	8003279	975200048	
250	.040 - .075	.285	.255	H-106-250L-C	H-108-0020L	8003286	975200048	
	Over .075	(1)		H-106-250L	H-108-0020L	8003280	975200048	

Metric	Pin Dia. Code	Test Sheet Thickness (mm)	Anvil Dimensions (mm)		HAEGER® Part Number		PEMSERTER® Part Number	
			A ±0.05	C ±0.05	Anvil	Punch	Anvil	Punch
	3MM	1 - 1.7	3.88	3.11	H-106-3MML-C	H-108-0020L	8008096	975200048
Over 1.7		(1)	H-106-3MML		H-108-0020L	8008095	975200048	
4MM	1 - 1.7	4.88	4.11	H-106-4MML-C	H-108-0020L	8003287	975200048	
	Over 1.7	(1)		H-106-4MML	H-108-0020L	8003281	975200048	
5MM	1 - 1.8	5.89	5.13	H-106-5MML-C	H-108-0020L	8003288	975200048	
	Over 1.8	(1)		H-106-5MML	H-108-0020L	8003282	975200048	
6MM	1 - 1.9	6.89	6.12	H-106-6MML-C	H-108-0020L	8003289	975200048	
	Over 1.9	(1)		H-106-6MML	H-108-0020L	8003283	975200048	

(1) Chamfered anvil not required.

Installation Notes

- For best results we recommend using a Haeger® or PEMSERTER® machine for installation of PEM® self-clinching fasteners. Please check our website for more information.
- Visit the Animation Library on our website to view the installation process for select products.



For Additional HAEGER® and PEMSERTER® Tooling Information/Part Numbers visit our [tooling wizard](#)



Self-Clinching Studs And Pins

Published installation forces are for general reference. Actual set-up and confirmation of complete installation should be made by observing proper seating of fastener as described in the installation steps. Other performance values reported are averages when all proper installation parameters and procedures are followed. Variations in mounting hole size, sheet material, and installation procedure may affect performance. Performance testing this product in your application is recommended. We will be happy to provide technical assistance and/or samples for this purpose.

Performance Data - FH™/FHS™ Flush-Head Studs

Unified	Thread Code	Rec. Nut Tightening Torque (in. lbs.) (1)	Type	Test Sheet Thickness & Material	Sheet Hardness HRB	Installation (lbs.)	Pushout (lbs.)	Torque-out (in. lbs.)	Pull Thru (lbs.)
	256	4.4	FH	.062" Aluminum	29	2000	100	5	425
		2.7	FHS	.062" Aluminum	29	2000	100	4.5	300
		4.4	FH	.060" Steel	59	2500	180	5	425
		2.7	FHS	.060" Steel	59	2500	180	4.5	300
	440	8.7	FH	.064" Aluminum	29	3800	170	10	650
		5.9	FHS	.064" Aluminum	29	3200	170	8	500
		8.7	FH	.060" Steel	59	4300	275	10	650
		5.9	FHS	.060" Steel	59	4700	275	8	500
	632	14	FH	.064" Aluminum	29	3800	180	17	850
11		FHS	.064" Aluminum	29	3500	180	16	775	
14		FH	.060" Steel	59	4700	300	20	850	
11		FHS	.060" Steel	59	5000	300	16	775	
832	20	FH	.064" Aluminum	29	4800	220	28	1000	
	16	FHS	.064" Aluminum	29	4500	220	28	940	
	25	FH	.060" Steel	59	6800	375	40	1270	
	19	FHS	.060" Steel	59	5500	375	28	1130	
032/024	28	FH	.064" Aluminum	29	5500	270	30	1220	
	24	FHS	.064" Aluminum	29	5500	270	30	1220	
	32	FH	.060" Steel	59	7500	450	60	1410	
	28	FHS	.060" Steel	59	6800	450	50	1410	
0420	69	FH	.093" Aluminum	28	6500	310	65	2300	
	55	FHS	.093" Aluminum	28	6500	310	65	2100	
	77	FH	.088" Steel	46	9500	575	100	2550	
	67	FHS	.088" Steel	46	10000	575	100	2550	
0518	85	FH	.093" Aluminum	28	6500	430	100	2260	
	74	FHS	.093" Aluminum	28	6700	430	100	2260	
	130	FH	.093" Steel	46	10000	650	175	3475	
	102	FHS	.093" Steel	46	11200	650	175	3120	

Metric	Thread Code	Rec. Nut Tightening Torque (N-m) (1)	Type	Test Sheet Thickness & Material	Sheet Hardness HRB	Installation (kN)	Pushout (N)	Torque-out (N-m)	Pull Thru (N)
	M2.5	0.78	FH	1.6 mm Aluminum	29	8.9	465	1.0	2600
		0.48	FHS	1.6 mm Aluminum	29	11.6	465	0.8	1820
		0.84	FH	1.5 mm Steel	59	11.1	740	1.0	2800
		0.48	FHS	1.5 mm Steel	59	13.8	740	0.8	1820
	M3	1.1	FH	1.6 mm Aluminum	29	12.9	600	1.7	3150
		0.81	FHS	1.6 mm Aluminum	29	12.9	600	1.3	2570
		1.4	FH	1.5 mm Steel	59	14.7	820	1.7	3840
		0.77	FHS	1.5 mm Steel	59	14.7	820	1.3	2440
	M3.5	1.6	FH	1.6 mm Aluminum	29	15.6	800	1.7	3780
1.3		FHS	1.6 mm Aluminum	29	15.6	800	1.7	3445	
1.6		FH	1.5 mm Steel	59	22.3	1335	2.8	3780	
1.3		FHS	1.5 mm Steel	59	22.3	1335	2.0	3445	
M4	2.1	FH	1.6 mm Aluminum	29	20	975	2.9	4448	
	1.8	FHS	1.6 mm Aluminum	29	22.3	975	2.9	4180	
	2.7	FH	1.5 mm Steel	59	28.9	1780	4.2	5650	
	2	FHS	1.5 mm Steel	59	26.7	1780	2.9	4775	
M5	3.1	FH	1.6 mm Aluminum	29	24.5	1070	3.5	5170	
	2.5	FHS	1.6 mm Aluminum	29	24.5	1070	3.5	4760	
	3.8	FH	1.5 mm Steel	59	33.4	2000	6.5	6270	
	3.2	FHS	1.5 mm Steel	59	32.5	2000	6.3	6000	
M6	7.3	FH	2.4 mm Aluminum	28	28.9	1660	7.3	10200	
	5.7	FHS	2.4 mm Aluminum	28	28.9	1660	7.3	9090	
	8.1	FH	2.2 mm Steel	46	44.5	2560	11.3	11300	
	6.7	FHS	2.2 mm Steel	46	44.5	2560	10.1	10600	
M8	10	FH	2.4 mm Aluminum	28	29.8	1910	11.3	10500	
	8	FHS	2.4 mm Aluminum	28	29.8	1910	11.3	9540	
	15	FH	2.4 mm Steel	46	44.5	2890	19.2	15450	
	11	FHS	2.4 mm Steel	46	49.8	2890	17.5	13630	

(1) Tightening torque shown is a theoretical value calculated to induce a load of 75% of minimum axial yield strength of the stud with an assumed K value or nut factor equal to 0.20. In some applications tightening torque may need to be adjusted based on the actual K value.

Performance Data - FHA™ Flush-Head Studs

Unified	Thread Code	Rec. Nut Tightening Torque (in. lbs.) ⁽¹⁾	Type	Test Sheet Thickness & Material	Sheet Hardness HR15T	Installation (lbs.)	Pushout (lbs.)	Torque-out (in. lbs.)	Pull Thru (lbs.)
	440	3.6	FHA	.061" 5052-H34 Aluminum	75	2500	155	4	270
	632	6.3	FHA	.061" 5052-H34 Aluminum	75	2600	180	8	380
	832	9.8	FHA	.061" 5052-H34 Aluminum	73	3200	190	15	500
	032	14	FHA	.061" 5052-H34 Aluminum	75	3200	220	28	600
	0420	32	FHA	.062" 5052-H34 Aluminum	75	5500	300	55	1050

Metric	Thread Code	Rec. Nut Tightening Torque (N-m) ⁽¹⁾	Type	Test Sheet Thickness & Material	Sheet Hardness HR15T	Installation (kN)	Pushout (N)	Torque-out (N-m)	Pull Thru (N)
	M3	0.54	FHA	1.55 mm 5052-H34 Aluminum	74	10.7	575	0.5	1500
	M4	0.96	FHA	1.55 mm 5052-H34 Aluminum	75	14.3	775	1.35	2000
	M5	1.5	FHA	1.55 mm 5052-H34 Aluminum	75	15.2	900	2.6	2500
	M6	3.2	FHA	1.6 mm 5052-H34 Aluminum	75	24.5	1500	5.3	4500

Performance Data - FH4™ Studs⁽²⁾

Unified	Thread Code	Rec. Nut Tightening Torque (in. lbs.) ⁽¹⁾	Test Sheet Thickness and Material ⁽³⁾	Sheet Hardness HRB	Installation (lbs.)	Pushout (lbs.)	Torque-out (in. lbs.)	Pull Thru (lbs.)
	440	11	.060" Stainless Steel	87	9000	450	16	800
	632	22	.060" Stainless Steel	87	9500	540	27	1350
	832	35	.060" Stainless Steel	86	11200	780	58	1800
	032	51	.060" Stainless Steel	86	12000	800	95	2250
	0420	117	.062" Stainless Steel	88	23000	1000	156	3900

Metric	Thread Code	Rec. Nut Tightening Torque (N-m) ⁽¹⁾	Test Sheet Thickness and Material ⁽³⁾	Sheet Hardness HRB	Installation (kN)	Pushout (N)	Torque-out (N-m)	Pull Thru (N)
	M3	1.3	1.5 mm Stainless Steel	87	40	2220	1.8	3500
	M4	3.8	1.5 mm Stainless Steel	86	50	3210	6.5	8000
	M5	6	1.5 mm Stainless Steel	86	53	3560	10.7	10000
	M6	11	1.6 mm Stainless Steel	88	100	4200	15.9	14900

Performance Data - FHP™ Studs⁽²⁾

Unified	Thread Code	Rec. Nut Tightening Torque (in. lbs.) ⁽¹⁾	Test Sheet Thickness and Material ⁽³⁾	Sheet Hardness HRB	Installation (lbs.)	Pushout (lbs.)	Torque-out (in. lbs.)	Pull Thru (lbs.)
	440	8.1	.045" Stainless Steel	86	9000	520	10.6	605
	632	16	.045" Stainless Steel	86	9500	670	19.5	940
	832	28	.045" Stainless Steel	86	11200	785	37.5	1415
	032	34	.045" Stainless Steel	86	12000	800	59.5	1500

Metric	Thread Code	Rec. Nut Tightening Torque (N-m) ⁽¹⁾	Test Sheet Thickness and Material ⁽³⁾	Sheet Hardness HRB	Installation (kN)	Pushout (N)	Torque-out (N-m)	Pull Thru (N)
	M3	1.3	2 mm Stainless Steel	86	40	2500	1.6	3500
	M4	2.9	1.14 mm Stainless Steel	86	50	3000	3.9	6000
	M5	4.4	1.14 mm Stainless Steel	86	53	3560	7.35	7320

- (1) Tightening torque shown is a theoretical value calculated to induce a load of 75% of minimum axial yield strength of the stud with an assumed K value or nut factor equal to 0.20. In some applications tightening torque may need to be adjusted based on the actual K value.
- (2) Performance values shown are typical for fasteners properly installed using raised ring tooling in good condition. We recommend replacing installation tooling when the height of the "P" falls out of tolerance (see page 18). Reductions in performance may occur as the height of the protrusion wears. Variations in hole preparation, installation force, and sheet material type, thickness, and hardness will affect both performance and tooling life.
- (3) Performance may be reduced for studs installed into thicker sheets.

Self-Clinching Studs And Pins

Performance Data - FHL™/FHLS™ Studs

Unified	Thread Code	Rec. Nut Tightening Torque (in. lbs.) ⁽¹⁾	Type	Test Sheet Thickness and Material	Sheet Hardness HRB	Installation (lbs.)	Pushout (lbs.)	Torque-out (in. lbs.)	Pull Thru (lbs.)	Pull Thru Test Bushing Hole Size (in.)
	256	2.1	FHL / FHLS	.047" Aluminum	33	700	55	4	230	.106
		3.8	FHL / FHLS	.045" Steel	54	1200	85	8	425	.106
	440	3.5	FHL / FHLS	.047" Aluminum	33	1000	60	5	300	.132
		6.8	FHL / FHLS	.045" Steel	54	1200	105	11	580	.132
	632	4.7	FHL / FHLS	.047" Aluminum	33	1000	65	6.5	325	.158
		9	FHL / FHLS	.045" Steel	54	1500	110	15	650	.158
	832	6	FHL / FHLS	.047" Aluminum	33	1200	80	9	350	.184
		13	FHL / FHLS	.045" Steel	54	1500	125	18	740	.184
	032	7.9	FHL / FHLS	.047" Aluminum	33	2500	115	18	395	.210
16		FHL / FHLS	.045" Steel	54	4500	210	38	800	.210	

Metric	Thread Code	Rec. Nut Tightening Torque (N-m) ⁽¹⁾	Type	Test Sheet Thickness and Material	Sheet Hardness HRB	Installation (kN)	Pushout (N)	Torque-out (N-m)	Pull Thru (N)	Pull Thru Test Bushing Hole Size (mm)
	M2.5	0.32	FHL / FHLS	1.2 mm Aluminum	33	3.1	285	0.55	1200	3
		0.59	FHL / FHLS	1.1 mm Steel	54	5.3	450	1.1	2250	3
	M3	0.41	FHL / FHLS	1.2 mm Aluminum	33	4.4	285	0.65	1300	3.5
		0.79	FHL / FHLS	1.1 mm Steel	54	5.3	475	1.25	2500	3.5
	M3.5	0.51	FHL / FHLS	1.2 mm Aluminum	33	4.4	290	0.76	1400	4
		1.03	FHL / FHLS	1.1 mm Steel	54	6.6	500	1.75	2800	4
	M4	0.65	FHL / FHLS	1.2 mm Aluminum	33	5.3	365	1.1	1550	4.5
		1.39	FHL / FHLS	1.1 mm Steel	54	6.6	550	2.1	3300	4.5
	M5	0.97	FHL / FHLS	1.2 mm Aluminum	33	11.1	530	2.2	1850	5.5
1.97		FHL / FHLS	1.1 mm Steel	54	20	1000	4.4	3750	5.5	

Performance Data - TFH™/TFHS™ Non-Flush Studs

Unified	Thread Code	Rec. Nut Tightening Torque (in. lbs.) ⁽¹⁾	Type	Test Sheet Thickness and Material	Sheet Hardness HRB	Installation (lbs.) ⁽²⁾	Pushout (lbs.)	Torque-out (in. lbs.)	Pull Thru (lbs.)	Pull Thru Test Bushing Hole Size (in.)
	440	9.2	TFH	.025" Aluminum	38	1300	75	10	683	.132
		6.2	TFHS	.025" Aluminum	38	1200	75	8	527	.132
		9.2	TFH	.022" Steel	57	2800	85	10	684	.132
		6.2	TFHS	.022" Steel	57	1500	80	9	531	.132
	632	13	TFH	.025" Aluminum	41	2400	87	9	791	.158
		11	TFHS	.025" Aluminum	41	2400	88	12	748	.158
		15	TFH	.022" Steel	57	2800	97	14	906	.158
		11	TFHS	.022" Steel	57	2800	100	16	750	.158
	832	19	TFH	.025" Aluminum	41	2100	94	14	943	.184
		17	TFHS	.025" Aluminum	41	2200	94	17	963	.184
		21	TFH	.022" Steel	57	3500	111	23	1065	.184
		19	TFHS	.022" Steel	57	2700	113	26	1109	.184
	024/032	24	TFH	.025" Aluminum	38	2300	98	13	1033	.210
		21	TFHS	.025" Aluminum	38	2500	101	12	1040	.210
		28	TFH	.022" Steel	57	3900	121	25	1214	.210
24		TFHS	.022" Steel	57	3200	112	23	1184	.210	

Metric	Thread Code	Rec. Nut Tightening Torque (N-m) ⁽¹⁾	Type	Test Sheet Thickness and Material	Sheet Hardness HRB	Installation (kN) ⁽²⁾	Pushout (N)	Torque-out (N-m)	Pull Thru (N)	Pull Thru Test Bushing Hole Size (mm)
	M3	1.1	TFH	0.65 mm Aluminum	42	5.8	370	0.72	3091	3.51
		0.93	TFHS	0.65 mm Aluminum	43	5.8	255	0.19	2962	3.51
		1.3	TFH	0.57 mm Steel	57	8	419	1.32	3477	3.51
		0.94	TFHS	0.57 mm Steel	57	6.7	394	0.84	2971	3.51
	M4	1.9	TFH	0.65 mm Aluminum	42	14.2	396	1.29	3963	4.5
		1.7	TFHS	0.65 mm Aluminum	40	9.8	391	1.83	4126	4.5
		2.1	TFH	0.57 mm Steel	57	17.8	453	1.69	4380	4.5
		2	TFHS	0.57 mm Steel	57	13.4	460	2.49	4701	4.5
	M5	2.8	TFH	0.64 mm Aluminum	42	3.2	499	1.71	4720	5.51
		2.6	TFHS	0.64 mm Aluminum	42	3.2	518	2.29	4977	5.51
		3.4	TFH	0.56 mm Steel	57	12.1	570	2.77	5654	5.51
2.8		TFHS	0.57 mm Steel	57	12.9	582	2.9	5328	5.51	

(1) Tightening torque shown is a theoretical value calculated to induce a load of 75% of minimum axial yield strength of the stud with an assumed K value or nut factor equal to 0.20. In some applications tightening torque may need to be adjusted based on the actual K value.

(2) Installation controlled by proper cavity depth in punch.

Performance Data - HFE™ Studs

Unified	Thread Code	Rec. Nut Tightening Torque (ft. lbs.) (1)	Test Sheet Thickness and Material (2) (in.)	Sheet Hardness HRB	Installation (lbs.) (3)	Pushout (lbs.)	Torque-out (in. lbs.)	Tensile Strength (lbs.) (4)	Pull Thru (lbs.)	Test Bushing Hole Size For Pull Thru Tests
	032	3.6	.040" Aluminum	27	7500	170	60	2400	1900	.279
4.2		.040" Cold-rolled Steel	67	9500	300	60	2400	2200		
0420	8	.040" Aluminum	27	8000	180	120	3820	3200	.335	
	9	.040" Cold-rolled Steel	67	13500	340	130	3820	3600		
0518	19	.060" Aluminum	22	9000	275	240	6280	6000	.407	
	20	.060" Cold-rolled Steel	65	15500	575	290	6280	6280		

Metric	Thread Code	Rec. Nut Tightening Torque (N-m) (1)	Test Sheet Thickness and Material (2) (mm)	Sheet Hardness HRB	Installation (kN) (3)	Pushout (N)	Torque-out (N-m)	Tensile Strength (kN) (4)	Pull Thru (kN)	Test Bushing Hole Size For Pull Thru Tests
	M5	5.8	1 mm Aluminum	27	37.7	690	8.1	12.8	9.7	7.4
6.4		1 mm Cold-rolled Steel	67	51.1	1350	8.1	12.8	10.6		
M6	10	1 mm Aluminum	27	39	750	11.8	18.1	14.2	8.2	
	11	1 mm Cold-rolled Steel	67	60	1400	14.4	18.1	15.5		
M8	24	1.5 mm Aluminum	22	42	1230	23.5	32.9	25	10.3	
	26	1.5 mm Cold-rolled Steel	65	71.1	2400	33.9	32.9	27.5		

Performance Data - THFE™ Studs

Unified	Thread Code	Rec. Nut Tightening Torque (ft. lbs.) (1)	Test Sheet Thickness and Material (2) (in.)	Sheet Hardness HRB	Installation (lbs.) (3)	Pushout (lbs.)	Torque-out (in. lbs.)	Tensile Strength (lbs.) (4)	Pull Thru (lbs.)	Test Bushing Hole Size For Pull Thru Tests
	0420	8.1	.031" Aluminum	35	8800	116	71	3820	3249	.340
8.5		.031" Cold-rolled Steel	47	13500	197	116	3820	3388		
0518	18	.031" Aluminum	44	11700	131	103	6280	5701	.402	
	18	.031" Cold-rolled Steel	47	16000	187	124	6280	5772		

Metric	Thread Code	Rec. Nut Tightening Torque (N-m) (1)	Test Sheet Thickness and Material (2) (mm)	Sheet Hardness HRB	Installation (kN) (3)	Pushout (N)	Torque-out (N-m)	Tensile Strength (kN) (4)	Pull Thru (kN)	Test Bushing Hole Size For Pull Thru Tests
	M6	9	0.8 mm Aluminum	38	39.2	550	7.3	18.1	13	8.3
10		0.8 mm Cold-rolled Steel	47	60.1	886	13.4	18.1	14.3		
M8	27	0.8 mm Aluminum	44	56	582	12.2	32.9	27.8	10.3	
	27	0.8 mm Cold-rolled Steel	47	71.2	881	13.1	32.9	28.1		

- (1) Tightening torque shown is a theoretical value calculated to induce a load of 75% of minimum axial yield strength of the stud with an assumed K value or nut factor equal to 0.20. In some applications tightening torque may need to be adjusted based on the actual K value.
- (2) See tech sheet on our website for performance data of PEM® Types HFE™ and THFE™ studs installed into copper sheets.
- (3) Installation controlled by proper cavity depth in punch.
- (4) Head size is adequate to ensure failure in threaded area when tested with industry standard tensile bushing diameter.

Self-Clinching Studs And Pins

Performance Data - HFH™/HFHS™/HFHB™ Studs

Unified	Thread Code	Type	Rec. Nut Tightening Torque (ft. lbs.) ⁽¹⁾	Test Sheet Thickness and Material	Sheet Hardness HRB	Installation (lbs.) ⁽²⁾	Pushout (lbs.)	Torque-out (ft. lbs.)	Tensile Strength (lbs.)
	032	HFH	4.6	.060" Aluminum	15	3000	180	4	2400
		HFH	4.6	.060" Steel	65	6000	375	5	2400
		HFHS	2.5	.050" Aluminum	38	3000	180	4	1500
		HFHS	2.5	.058" Steel	52	4500	325	4	1500
		HFHB	1.7	.061" Copper CDA-110	28	3400	150	2.9	1200
	0420	HFH	9.6	.060" Aluminum	43	5500	285	11	3820
		HFH	9.6	.060" Steel	59	7000	480	11	3820
		HFHS	5.2	.064" Aluminum	32	4000	285	8	2385
		HFHS	5.2	.072" Steel	43	6500	480	8	2385
HFHB		3.6	.061" Copper CDA-110	28	6000	380	5	1908	
0518	HFH	20	.091" Aluminum	39	8000	380	22	6280	
	HFH	20	.090" Steel	58	10000	590	22	6280	
	HFHS	11	.087" Aluminum	41	5500	380	15	3930	
	HFHS	11	.099" Steel	44	7500	590	15	3930	
	HFHB	7	.126" Copper CDA-110	32	7500	500	11	3140	
0616	HFH	35	.091" Aluminum	39	12000	550	25	9300	
	HFH	35	.090" Steel	58	16000	780	36	9300	
	HFHS	19	.123" Aluminum	44	10000	560	25	5810	
	HFHS	19	.099" Steel	44	13000	780	25	5810	
	HFHB	13	.126" Copper CDA-110	32	12000	560	18	4650	

Metric	Thread Code	Type	Rec. Nut Tightening Torque (N-m) ⁽¹⁾	Test Sheet Thickness and Material	Sheet Hardness HRB	Installation (kN) ⁽²⁾	Pushout (N)	Torque-out (N-m)	Tensile Strength (kN)
	M5	HFH	7.7	1.5 mm Aluminum	15	13	800	5.4	12.8
		HFH	7.7	1.5 mm Steel	65	26	1500	7.6	12.8
		HFHS	3.8	1.62 mm Aluminum	35	12.4	800	5.4	7.3
		HFHS	3.8	1.47 mm Steel	54	21.7	1500	6.4	7.3
		HFHB	2.7	1.5 mm Copper CDA-110	28	15.6	1115	3.4	5.9
	M6	HFH	13	1.5 mm Aluminum	43	29	1270	14	18.1
		HFH	13	1.5 mm Steel	59	33	1750	14	18.1
		HFHS	6.5	1.62 mm Aluminum	35	15.4	1270	11	10.3
		HFHS	6.5	1.6 mm Steel	45	24.6	1750	11	10.3
HFHB		4.5	1.5 mm Copper CDA-110	28	25.3	1600	6.7	8.3	
M8	HFH	32	2.3 mm Aluminum	39	35.6	1700	30	32.9	
	HFH	32	2.3 mm Steel	58	44.5	2200	30	32.9	
	HFHS	16	2.23 mm Aluminum	44	24.4	1700	20	18.8	
	HFHS	16	2.48 mm Steel	43	37.8	2100	20	18.8	
	HFHB	11	3.2 mm Copper CDA-110	32	33	2250	15.3	15.1	
M10	HFH	63	2.3 mm Aluminum	39	53.3	2445	36	52.2	
	HFH	63	2.3 mm Steel	58	71.2	3470	49	52.2	
	HFHS	31	2.3 mm Aluminum	44	44.4	2445	36	29.9	
	HFHS	31	2.3 mm Steel	44	57.7	3470	36	29.9	
	HFHB	22	3.2 mm Copper CDA-110	32	53.3	2500	25	24	

Performance Data - HFG8™/HF109™ High Tensile Strength Studs

Unified	Thread Code	Rec. Nut Tightening Torque (ft. lbs.)	Tensile Strength (lbs.) ⁽³⁾	Test Sheet Material	Sheet Hardness HRB	Installation (lbs.) ⁽²⁾	Pushout (lbs.)	Torque-out (ft. lbs.)	Test Sheet Material	Sheet Hardness HRB	Installation (lbs.) ⁽²⁾	Pushout (lbs.)	Torque-out (ft. lbs.)
	032	6.4	3000	.047" HSLA Steel	85.5	14000	483	6.2	.040" Cold-rolled Steel	45.0	9900	249	5.9
	0420	13	4750	.047" HSLA Steel	85.7	21400	592	11.5	.040" Cold-rolled Steel	45.0	14100	248	11.5
	0518	28	7850	.060" HSLA Steel	84.9	32600	667	25.6	.060" Cold-rolled Steel	55.2	19100	447	25.2

Metric	Thread Code	Rec. Nut Tightening Torque (N-m)	Tensile Strength (kN) ⁽³⁾	Test Sheet Material	Sheet Hardness HRB	Installation (kN) ⁽²⁾	Pushout (N)	Torque-out (N-m)	Test Sheet Material	Sheet Hardness HRB	Installation (kN) ⁽²⁾	Pushout (N)	Torque-out (N-m)
	M5	10	14.8	1.2 mm HSLA Steel	86.1	60.1	2084	9	1 mm Cold-rolled Steel	45.3	43.2	978	9
	M6	17	20.9	1.2 mm HSLA Steel	85.6	90	2454	15.6	1 mm Cold-rolled Steel	45.5	60	1072	14.4
	M8	41	38.1	1.5 mm HSLA Steel	84	145	3026	38.4	1.5 mm Cold-rolled Steel	55	85	1992	37.7

(1) Tightening torque shown is a theoretical value calculated to induce a load of 75% of minimum axial yield strength of the stud with an assumed K value or nut factor equal to 0.20. In some applications tightening torque may need to be adjusted based on the actual K value.

(2) Installation controlled by proper cavity depth in punch.

(3) Head size is adequate to ensure failure in threaded area when tested with industry standard tensile bushing diameter.

Performance Data - HFLH™ Studs

Unified	Thread Code	Rec. Nut Tightening Torque (ft. lbs.) ⁽¹⁾	Test Sheet Thickness and Material (in.)	Sheet Hardness HRB	Installation (lbs.) ⁽²⁾	Pushout (lbs.)	Torque-out (in. lbs.)	Tensile Strength (lbs.) ⁽³⁾	Pull Thru (lbs.)	Test Bushing Hole Size For Pull Thru Tests
	032	4.2	.040" HC500LA	89	9500	300	60	2400	2200	.279
	0420	10	.040" HC500LA	89	13500	340	130	3820	3600	.335
	0518	23	.060" HC500LA	91	16000	575	290	6280	6280	.407

Metric	Thread Code	Rec. Nut Tightening Torque (N-m) ⁽¹⁾	Test Sheet Thickness and Material (mm)	Sheet Hardness HRB	Installation (kN) ⁽²⁾	Pushout (N)	Torque-out (N-m)	Tensile Strength (kN) ⁽³⁾	Pull Thru (kN)	Test Bushing Hole Size For Pull Thru Tests
	M5	6.4	1 mm HC500LA	89	51.1	1350	8.1	12.8	10.6	7.4
	M6	11	1 mm HC500LA	89	60	1400	14.4	18.1	15.5	8.2
	M8	26	1.5 mm HC500LA	91	71.1	2400	33.9	32.9	27.5	10.3

Performance Data - SGPC™ Swaging Collar Studs

Unified	Thread Code	Rec. Nut Tightening Torque (in. lbs.) ⁽¹⁾	Test Sheet Material			
			Single sheet of .039" 300 Series Stainless Steel			
			Installation (lbs.)	Pushout (lbs.)	Torque-out (in. lbs.)	Pull-thru (lbs.)
	256	3.7	4000	425	5.2	415
440	6	5000	450	8	512	
632	12	5500	460	15.8	811	
832	20	6500	480	29.3	1133	
032	25	7300	545	42.8	1273	
0420	45	10000	565	76.7	1721	

Metric	Thread Code	Rec. Nut Tightening Torque (N-m) ⁽¹⁾	Test Sheet Material			
			Single sheet of 1 mm 300 Series Stainless Steel			
			Installation (kN)	Pushout (N)	Torque-out (N-m)	Pull-thru (N)
	M2.5	0.67	20.1	2546	0.86	2561
M3	0.9	21.8	2051	1.35	2851	
M4	2.5	28.5	2396	2.66	4000	
M5	3.3	35.6	3200	5.96	4284	
M6	3.3	42.3	3262	9.19	6311	

Performance Data - FHX™ Studs With X-Press™ Thread Profile

Thread Code	Test Sheet Material ⁽⁴⁾	Installation kN	Pushout N	Torque-out N-m
X5	1.1 mm Steel HRB 58 / HB 104	24.9	1519	4.7
	1.2 mm Aluminum HRB 44 / HB 66	19.2	1070	3.2
X6	1.6 mm Steel HRB 58 / HB 104	35.6	2964	13.3
	1.6 mm Aluminum HRB 44 / HB 66	29.4	1623	7

- (1) Tightening torque shown is a theoretical value calculated to induce a load of 75% of minimum axial yield strength of the stud with an assumed K value or nut factor equal to 0.20. In some applications tightening torque may need to be adjusted based on the actual K value.
- (2) Installation controlled by proper cavity depth in punch.
- (3) Head size is adequate to ensure failure in threaded area when tested with industry standard tensile bushing diameter.
- (4) HRB - Hardness Rockwell "B" Scale. HB - Hardness Brinell.

Performance Data - TPS™ Pilot Pins

Unified	Pin Dia. Code	Test Sheet Material	Sheet Hardness HRB	Installation (lbs.)	Pushout (lbs.)
	125	Aluminum	20	4500	150
Steel		62	6500	250	
187	Aluminum	18	6500	230	
	Steel	60	8000	400	
250	Aluminum	18	7000	270	
	Steel	62	9000	500	

Metric	Pin Dia. Code	Test Sheet Material	Sheet Hardness HRB	Installation (kN)	Pushout (kN)
	3MM	Aluminum	22	12	0.56
Steel		65	22	0.98	
4MM	Aluminum	19	22	0.89	
	Steel	66	26.4	1.54	
5MM	Aluminum	18	28.6	1.01	
	Steel	60	35.2	1.76	
6MM	Aluminum	18	30.8	1.1	
	Steel	62	39.6	2.1	

Performance Data - TP4™ Pilot Pins

Unified	Pin Dia. Code	Test Sheet Material	Installation (lbs.)	Pushout (lbs.)
	125	300 Series Stainless Steel	8000	350
	187	300 Series Stainless Steel	12000	570
	250	300 Series Stainless Steel	14000	650

Metric	Pin Dia. Code	Test Sheet Material	Installation (kN)	Pushout (N)
	3MM	300 Series Stainless Steel	35	1556
	4MM	300 Series Stainless Steel	45	2335
	5MM	300 Series Stainless Steel	54	2535
	6MM	300 Series Stainless Steel	60	2891

Performance Data - TPXS™ Pilot Pins

Metric	Pin Dia. Code	Test Sheet Material	Sheet Hardness HRB	Installation (kN)	Pushout (kN)
	3MM	Aluminum	22	12	0.56
		Steel	65	22	0.98

Custom sizes are available on special order.
[Contact us](#) for more information.

PEM® Dimple
(Registered Trademark)



Fastener drawings and
models are available at
www.pemnet.com

All PEM® products meet our stringent quality standards. If you require additional industry or other specific [quality certifications](#), special procedures and/or part numbers are required. Please contact your local sales office or representative for further information.

Regulatory [compliance information](#) is available in Technical Support section of our website. Specifications subject to change without notice. See our website for the most current version of this bulletin.



North America: Danboro, Pennsylvania USA | E-mail: info@pemnet.com | Tel: +1-215-766-8853 | 800-237-4736 (USA)

Europe: Galway, Ireland | E-mail: europa@pemnet.com | Tel: +353-91-751714

Asia/Pacific: Singapore | E-mail: singapore@pemnet.com | Tel: +65-6-745-0660

Kunshan, China: E-mail: salesgreaterchina@pemnet.com | Tel: +86-512-5276-9300

Visit our PEMNET™ Resource Center at www.pemnet.com • Technical support e-mail: techsupport@pemnet.com