

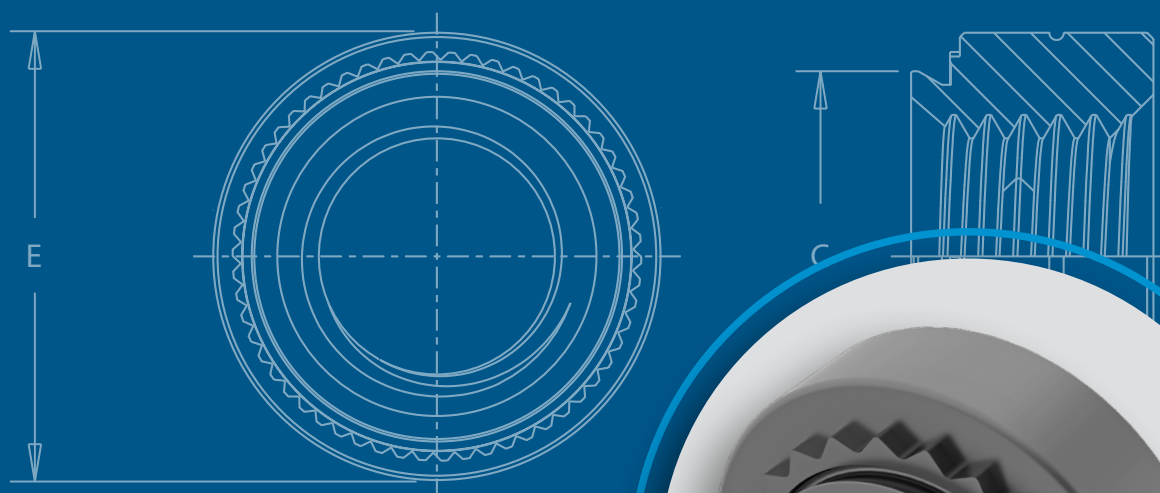

CLTM SELF-CLINCHING NUTS



PEM® brand self-clinching nuts install permanently in aluminum, steel or stainless steel sheets.



Self-clinching nuts are installed by placing them in properly sized holes in sheets and applying a parallel squeezing force to the head of the nut. The sheet metal surrounding the head cold flows into an undercut thereby making the fastener an integral part of the sheet. A serrated clinching ring prevents the fastener from rotating after installation.

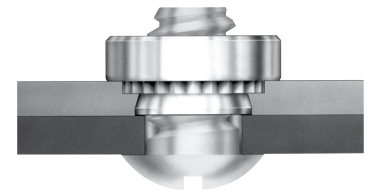

Fastener drawings and models are available at www.pemnet.com. Custom sizes are available on special order. [Contact us](#) for more information.

ST™/SS™/CLA™/CLS™/CLSS™ nuts

provide load-bearing threads in thin sheets with high pushout and torque-out resistance — PAGES 4 and 5



H™ (non-locking) and HNL™ (locking) nuts

have threads that provide high pushout and torque-out resistance — PAGE 8



SP™, PEM 300® nuts

provide strong load-bearing threads in stainless steel sheets as thin as .030"/0.8 mm — PAGES 4 and 5



SH™ hard panel nuts

install into thin, harder, high strength steel materials — PAGE 8



PEM RT® free-running locknuts

are free-running until clamp load is induced. A modified thread angle on the loaded flank provides the vibration resistant locking feature — PAGE 6



SMPS™/SMPP™ nuts

are for thinner sheet/close-to-edge applications — PAGE 9



Material and finish specifications

— PAGE 9

SL™ self-locking nuts

are designed with a unique and economical TRI-DENT® locking feature, meeting 3 cycle locking performance requirements — PAGE 7



Installation

— PAGES 10 and 13

Performance data

— PAGES 14 - 17

Many PEM self-clinching nuts in this bulletin are dimensionally equivalent to nuts manufactured to NASM45938/1 specifications. Consult our Marketing department for a complete Military Specifications and National Aerospace Standards guide (Bulletin NASM) on our website.

Screws for use with PEM self-clinching locking fasteners should be Class 3A/4h fit or no smaller than Class 2A/6g.

PEM® Stamp
(Registered Trademark)



PEM® Two Groove
(Registered Trademark)

PEM® RT Stamp
(Registered Trademark)



SH
(Registered Trademark)

Fasteners For Stainless Steel

SMPP
Identification Mark

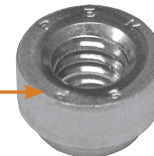

SMPP
Identification Mark

Custom sizes are available on special order. [Contact us](#) for more information.

PEM® Self-Clinching Nut Selector Guide

PEM Nut Type	Application Requires:									
	Recommended panel material (1)	Thinnest sheet .025" / 0.64 mm	Locking Threads		Closest centerline-to-edge distance	Superior corrosion resistance	Recommended for installation into stainless steel sheets	Compatible with aluminum anodizing	Harder high strength steel material	Non-magnetic
			Free-running	Prevailing torque						
S/SS/H	steel / aluminum									
CLS/CLSS	steel / aluminum					▪				▪
CLA	aluminum					▪	▪			▪
SP	stainless steel					▪	▪			▪
PEM RT®	steel / aluminum		▪							
SL	steel / aluminum			▪						
HNL	aluminum			▪						
SH	hardened alloy steel							▪		
SMPS	steel / aluminum	▪			▪	▪				▪
SMPP	stainless steel	▪			▪	▪	▪			▪

(1) Describes "best practice" for typical applications. Fasteners can be used in other panel materials not listed here if specified hardness limits are met. In all cases "For Use in Sheet Hardness" information is shown in chart on page 9.

PEM® PreTect™ Thread Masking Plugs

PEM® PreTect™ thread masking plugs have been redesigned for improved thread protection during the paint or powder coating process. PreTect™ plugs are available for standard type self-clinching nuts in a variety of thread sizes and materials. [Click here](#) for more information.

Add the suffix "TP" to PEM® part number to order fastener with pre-installed thread masking plug.



Available Pem® Varimount® Fastening System

The PEM® VariMount® fastening system (see PEM® Bulletin VM) utilizes a self-clinching nut paired with a round steel or stainless steel base plate to offer a clean and ready-made assembly for mounting into any rigid material or panel, including composites, plastics, and metals. Multiple radial holes in the base plate and a generous footprint provide effective mounting of the assembly. Mounting can be performed either on the front or through the back of a panel.



Self-Clinching Nuts

- S/SS nuts are recommended for use in steel or aluminum sheets HRB 80 / HB 150 or less.
- CLS/CLSS nuts are recommended for use in steel or aluminum sheets HRB 70 / HB 125 or less.
- SP nuts are recommended for use in stainless steel sheets HRB 90 / HB 192 or less.
- CLA nuts are recommended for use in steel or aluminum sheets HRB 50 / HB 82 or less.

Part Number Designation

S	-	632	-	1	ZI
SS	-	032	-	1	ZI
CL	S	632	-	1	
CLS	S	032	-	1	
S	P	632	-	1	
CL	A	632	-	1	

↓
↓
↓
↓
↓

Type Material Code Thread Size Code Shank Code Finish

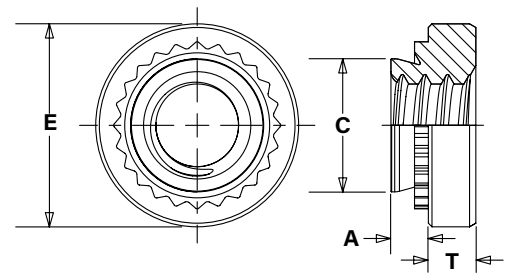

(Clinching profile may vary)
Due to manufacturing procedure, parts may have a counterbore at shank end.

S™/SS™/CLS™/CLSS™/SP™ Nuts

All dimensions are in inches.

Unified	Thread Size	Type			Thread Code	Shank Code	A (Shank) Max.	Rec. Min. Sheet Thickness (1)	Hole Size In Sheet +.003 -.000	C Max.	E ±.010	T ±.010	Min. Dist. Hole C/L to Edge (4)
		Fastener Material											
		Carbon Steel	Stainless Steel	Hardened Stainless Steel									
.086-56 (#2-56)	S	CLS	SP	256	0	.030	.030	.166	.165	.250	.070	.19	
					1	.038	.040						
					2	.054	.056						
					3 ⁽²⁾	.087	.090						
.099-48 (#3-48)	S	CLS	—	348	0	.030	.030	.166	.165	.250	.070	.19	
					1	.038	.040						
					2	.054	.056						
					3 ⁽²⁾	.087	.090						
.112-40 (#4-40)	S	CLS	SP	440	0	.030	.030	.166	.165	.250	.070	.19	
					1	.038	.040						
					2	.054	.056						
					3 ⁽²⁾	.087	.090						
.138-32 (#6-32)	S	CLS	SP	632	0	.030	.030	.1875	.187	.280	.070	.22	
					1	.038	.040						
					2	.054	.056						
					3 ⁽²⁾	.087	.090						
.164-32 (#8-32)	S	CLS	SP	832	0	.030	.030	.213	.212	.310	.090	.27	
					1	.038	.040						
					2	.054	.056						
					3 ⁽²⁾	.087	.090						
.190-24 (#10-24)	SS	CLSS	SP	024	0	.030	.030	.250	.249	.340	.090	.28	
					1	.038	.040						
					2	.054	.056						
					3 ⁽²⁾	.087	.090						
.190-32 (#10-32)	SS	CLSS	SP	032	0	.030	.030	.250	.249	.340	.090	.28	
					1	.038	.040						
					2	.054	.056						
					3 ⁽²⁾	.087	.090						
.216-24 (#12-24)	S	CLS	—	1224	1	.038	.040	.277	.276	.370	.130	.31	
					2	.054	.056						
					3	.087	.090						
					3 ⁽²⁾	.120	.125						
.250-20 (1/4-20)	S ⁽³⁾	CLS	SP	0420	0	.045	.047	.344	.343	.440	.170	.34	
					1	.054	.056						
					2	.087	.090						
					3 ⁽²⁾	.120	.125						
.250-28 (1/4-28)	S	CLS	—	0428	1	.054	.056	.344	.343	.440	.170	.34	
					2	.087	.090						
					3	.120	.125						
					3 ⁽²⁾	.120	.125						
.313-18 (5/16-18)	S ⁽³⁾	CLS	SP	0518	1	.054	.056	.413	.412	.500	.230	.38	
					2	.087	.090						
					3 ⁽²⁾	.120	.125						
					3 ⁽²⁾	.120	.125						
.313-24 (5/16-24)	S	CLS	SP	0524	1	.054	.056	.413	.412	.500	.230	.38	
					2	.087	.090						
					3 ⁽²⁾	.120	.125						
					3 ⁽²⁾	.120	.125						
.375-16 (3/8-16)	S	CLS	SP	0616	1	.087	.090	.500	.499	.560	.270	.44	
					2	.120	.125						
					3 ⁽²⁾	.235	.250						
					3 ⁽²⁾	.235	.250						
.375-24 (3/8-24)	S	CLS	SP	0624	1	.087	.090	.500	.499	.560	.270	.44	
					2	.120	.125						
					3 ⁽²⁾	.235	.250						
					3 ⁽²⁾	.235	.250						
.438-20 (7/16-20)	S	—	—	0720	1	.087	.092	.562	.561	.687	.311	.562	
					2	.120	.125						
.500-13 (1/2-13)	S	CLS	—	0813	1	.120	.125	.656	.655	.810	.360	.63	
					2	.235	.250						
.500-20 (1/2-20)	S	CLS	—	0820	1	.120	.125	.656	.655	.810	.360	.63	
					2	.235	.250						

- For maximum performance, we recommend that you use the maximum shank length for your sheet thickness.
- This shank code not available for SP nuts.
- This thread size S nut, with a -2 shank code, can be installed successfully without the need to pre punch a mounting hole in a separate operation. See page 18 for more information.
- For more information on proximity to bends and distance to other clinch hardware, see PEM® Tech Sheet C/L To Edge.

The increased hardness of stainless steel panels requires careful consideration when installing self-clinching fasteners. See page 16 or refer to Fastener Installation Dos and Don'ts on our website.

Self-Clinching Nuts

STTM/SSTM/CLSTM/CLSSTM/SPTM Nuts

(See drawing at top of page 4) All dimensions are in millimeters.

Metric	Thread Size	Type			Thread Code	Shank Code	A (Shank) Max.	Rec. Min. Sheet Thickness (1)	Hole Size In Sheet +0.08	C Max.	E ±0.25	T ±0.25	Min. Dist. Hole C/L To Edge (4)
		Fastener Material											
		Carbon Steel	Stainless Steel	Hardened Stainless Steel									
M2 x 0.4	S	CLS	SP	M2	0 ⁽²⁾	0.77	0.8	4.22	4.2	6.35	1.5	4.8	
					1	0.97	1						
					2	1.38	1.4						
M2.5 x 0.45	S	CLS	SP	M2.5	0	0.77	0.8	4.22	4.2	6.35	1.5	4.8	
					1	0.97	1						
					2	1.38	1.4						
M3 x 0.5	S	CLS	SP	M3	0	0.77	0.8	4.22	4.2	6.35	1.5	4.8	
					1	0.97	1						
					2	1.38	1.4						
M3.5 x 0.6	S	CLS	—	M3.5	0	0.77	0.8	4.75	4.73	7.11	1.5	5.6	
					1	0.97	1						
					2	1.38	1.4						
M4 x 0.7	S	CLS	SP	M4	0	0.77	0.8	5.41	5.38	7.87	2	6.9	
					1	0.97	1						
					2	1.38	1.4						
M5 x 0.8	SS	CLSS	SP	M5	0	0.77	0.8	6.35	6.33	8.64	2	7.1	
					1	0.97	1						
					2	1.38	1.4						
M6 x 1	S ⁽³⁾	CLS	SP	M6	00 ⁽²⁾	0.89	0.92	8.75	8.73	11.18	4.08	8.6	
					0 ⁽²⁾	1.15	1.2						
					1	1.38	1.4						
					2	2.21	2.29						
M8 x 1.25	S ⁽³⁾	CLS	SP	M8	1	1.38	1.4	10.5	10.47	12.7	5.47	9.7	
					2	2.21	2.29						
M10 x 1.5	S	CLS	SP	M10	1	2.21	2.29	14	13.97	17.35	7.48	13.5	
					2 ⁽²⁾	3.05	3.18						
M12 x 1.75	S	—	—	M12	1	3.05	3.18	17	16.95	20.57	8.5	16	

CLATM Nuts

(See drawing at top of page 4) All dimensions are in inches.

Unified	Thread Size	Type		Thread Code	Shank Code	A (Shank) Max.	Min. Sheet Thickness (1)	Hole Size In Sheet ±.003 -.000	C Max.	E ±.010	T ±.010	Min. Dist. Hole C/L to Edge (4)
		Fastener Material										
		Aluminum										
.086-.56 (#2-.56)	CLA	256	1	.038	.040	.166	.165	.250	.070	.19		
			2	.054	.056							
.112-.40 (#4-.40)	CLA	440	1	.038	.040	.1875	.187	.250	.090	.22		
			2	.054	.056							
.138-.32 (#6-.32)	CLA	632	1	.038	.040	.213	.212	.280	.090	.27		
			2	.054	.056							
.164-.32 (#8-.32)	CLA	832	1	.038	.040	.234	.233	.310	.130	.28		
			2	.054	.056							
.190-.24 (#10-.24)	CLA	024	1	.038	.040	.296	.295	.370	.160	.31		
			2	.054	.056							
.190-.32 (#10-.32)	CLA	032	1	.038	.040	.296	.295	.370	.160	.31		
			2	.054	.056							
.250-.20 (1/4-.20)	CLA	0420	1	.054	.056	.344	.343	.440	.170	.34		
			2	.087	.091							
			3	.120	.125							

(See drawing at top of page 4) All dimensions are in millimeters.

Metric	Thread Size x Pitch	Type		Thread Code	Shank Code	A (Shank) Max.	Min. Sheet Thickness (1)	Hole Size In Sheet +0.08	C Max.	E ±0.25	T ±0.25	Min. Dist. Hole C/L to Edge (4)
		Fastener Material										
		Aluminum										
M2 x 0.4	CLA	M2	1	0.98	1	4.22	4.2	6.35	1.5	4.8		
			2	1.38	1.4							
M3 x 0.5	CLA	M3	1	0.98	1	4.75	4.73	6.35	2	5.6		
			2	1.38	1.4							
M3.5 x 0.6	CLA	M3.5	1	0.98	1	5.41	5.38	7.11	2	6.9		
			2	1.38	1.4							
M4 x 0.7	CLA	M4	1	0.98	1	5.94	5.92	7.8	3	7.1		
			2	1.38	1.4							
M5 x 0.8	CLA	M5	1	0.98	1	7.52	7.49	9.4	3.8	7.9		
			2	1.38	1.4							
M6 x 1	CLA	M6	1	1.38	1.4	8.75	8.73	11.18	4.08	8.6		
			2	2.21	2.3							

- (1) For maximum performance, we recommend that you use the maximum shank length for your sheet thickness.
- (2) This shank code not available for SP nuts.
- (3) This thread size S nut, with a -2 shank code, can be installed successfully without the need to pre punch a mounting hole in a separate operation. See page 18 for more information.
- (4) For more information on proximity to bends and distance to other clinch hardware, see [PEM® Tech Sheet C/L To Edge](#).

PEM RT® Free-Running Locknuts

Free-running locking feature allows screw to turn freely until clamp load is applied. If the tightening force is removed, these nuts no longer provide any torsional resistance to rotation until clamp load is reapplied.

- Resistant to vibrational loosening.
- Back side of panel is flush or sub-flush for screw installation.
- Locking feature reusability is not affected by number of on/off cycles.
- Uses same mounting hole and installation tooling as standard S™ nuts.
- Recommended for use in steel or aluminum sheets HRB 80 / HB 150 or less.

Part Number Designation

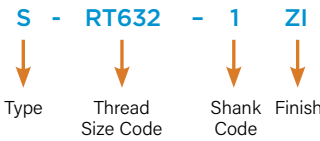

PEM RT® free-running locking feature can be added to other PEM® internally threaded nuts.

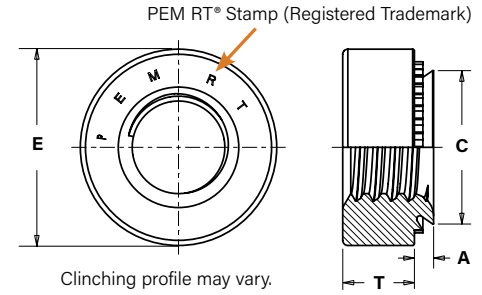

All dimensions are in inches.

Unified	Thread Size	Type	Thread Code	Shank Code	A (Shank) Max.	Rec. Min. Sheet Thickness (1)	Hole Size In Sheet +.003 -.000	C Max.	E ±.010	T ±.010	Min. Dist Hole C/L to Edge (2)
	.112-40 (#4-40)	S	RT440	0	.030	.030	.166	.165	.250	.070	.19
1	.038			.040							
2	.054			.056							
.138-32 (#6-32)	S	RT632	0	.030	.030	.1875	.187	.280	.070	.22	
1			.038	.040							
2			.054	.056							
.164-32 (#8-32)	S	RT832	0	.030	.030	.213	.212	.310	.090	.27	
1			.038	.040							
2			.054	.056							
.190-32 (#10-32)	SS	RT032	0	.030	.030	.250	.249	.340	.090	.28	
1			.038	.040							
2			.054	.056							
.250-20 (1/4-20)	S	RT0420	0	.045	.047	.344	.343	.440	.170	.34	
1			.054	.056							
2			.087	.090							
.313-18 (5/16-18)	S	RT0518	1	.054	.056	.413	.412	.500	.230	.38	
2			.087	.090							

All dimensions are in millimeters

Metric	Thread Size x Pitch	Type	Thread Code	Shank Code	A (Shank) Max.	Rec. Min. Sheet Thickness (1)	Hole Size In Sheet +0.08	C Max.	E ±0.25	T ±0.25	Min. Dist Hole C/L to Edge (2)
	M3 x 0.5	S	RTM3	0	0.77	0.8	4.22	4.2	6.35	1.5	4.8
1				0.97	1						
2				1.38	1.4						
M4 x 0.7	S	RTM4	0	0.77	0.8	5.41	5.38	7.87	2	6.9	
			1	0.97	1						
			2	1.38	1.4						
M5 x 0.8	SS	RTM5	0	0.77	0.8	6.35	6.33	8.64	2	7.1	
			1	0.97	1						
			2	1.38	1.4						
M6 x 1	S	RTM6	00	0.89	0.92	8.75	8.73	11.18	4.08	8.6	
			0	1.15	1.2						
			1	1.38	1.4						
			2	2.21	2.29						
M8 x 1.25	S	RTM8	1	1.38	1.4	10.5	10.47	12.7	5.47	9.7	
			2	2.21	2.29						

(1) For maximum performance, we recommend that you use the maximum shank length for your sheet thickness.

(2) For more information on proximity to bends and distance to other clinch hardware, see PEM® Tech Sheet C/L To Edge.

The graph represents the clamp load of the joint versus the amount of cycles during transverse vibration testing for an PEM RT® free-running locknut, a standard S nut, a split ring lock washer and Loctite Red 271.

Testing conditions:

Transverse vibration testing.

M6 thread size nuts, average of 30 pieces.

Clamp load applied using metric property class 12.9 screws.

Nuts tested until loss of clamp load or 2,000 cycles is reached.

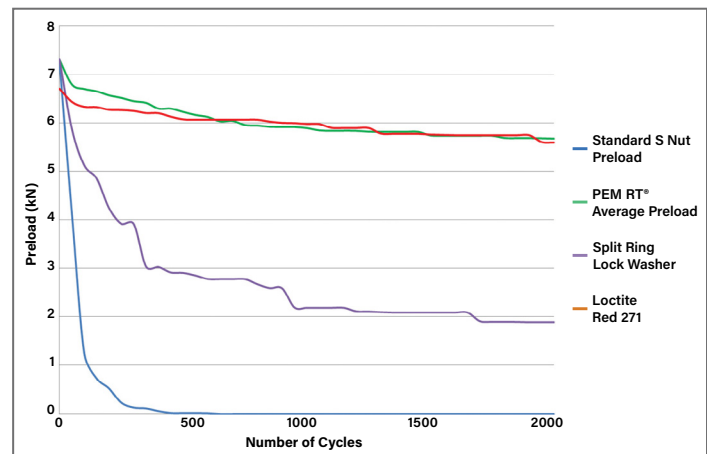

Details on PEM RT® vibration resistant thread technology can be found on our [website](http://www.pemnet.com).

SL™ Tri-Dent® Prevailing Torque Locknuts

Prevailing torque locking feature produces friction between threads of mated components thereby increasing the force needed to tighten as well as loosen the nut. Prevailing torque locknuts provide essentially the same torque value regardless of the amount axial load applied.

- 3 cycle locking performance. (1)
- Resistant to vibrational loosening.
- Back side of panel is flush or sub-flush for screw installation.
- Uses same mounting hole and installation tooling as standard S™ nuts.
- Recommended for use in sheets HRB 80 / HB 150 or less.

Part Number Designation

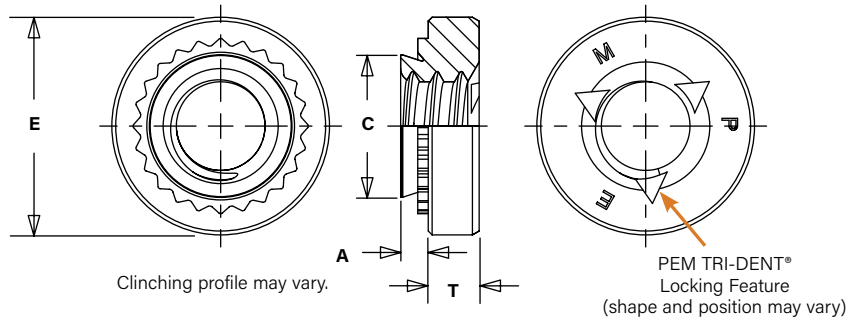
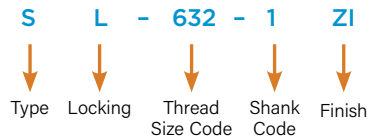

All dimensions are in inches.

Unified	Thread Size	Type	Thread Code	Shank Code	A (Shank) Max.	Min. Sheet Thickness	Hole Size In Sheet +.003 -.000	C Max.	E ±.010	T ±.010	Min. Dist. Hole C/L to Edge (2)
	.112-40 (#4-40)	SL	440	1	.038	.040	.166	.165	.250	.070	.19
.054					.056						
.138-32 (#6-32)	SL	632	1	.038	.040	.1875	.187	.280	.070	.22	
				.054	.056						
.164-32 (#8-32)	SL	832	1	.038	.040	.213	.212	.310	.090	.27	
				.054	.056						
.190-32 (#10-32)	SL	032	1	.038	.040	.250	.249	.340	.090	.28	
				.054	.056						
.250-20 (1/4-20)	SL	0420	1	.054	.056	.344	.343	.440	.170	.34	
				.087	.091						
.313-18 (5/16-18)	SL	0518	1	.054	.056	.413	.412	.500	.230	.38	
				.087	.091						

All dimensions are in millimeters.

Metric	Thread Size x Pitch	Type	Thread Code	Shank Code	A (Shank) Max.	Min. Sheet Thickness	Hole Size In Sheet +0.08	C Max.	E ±0.25	T ±0.25	Min. Dist. Hole C/L to Edge (2)
	M3 x 0.5	SL	M3	1	0.98	1	4.22	4.2	6.35	1.5	4.8
1.38					1.4						
M3.5 x 0.6	SL	M3.5	1	0.98	1	4.75	4.73	7.11	1.5	5.6	
				1.38	1.4						
M4 x 0.7	SL	M4	1	0.98	1	5.41	5.38	7.87	2	6.9	
				1.38	1.4						
M5 x 0.8	SL	M5	1	0.98	1	6.35	6.33	8.64	2	7.1	
				1.38	1.4						
M6 x 1	SL	M6	1	1.38	1.4	8.75	8.73	11.18	4.08	8.6	
				2.21	2.3						
M8 x 1.25	SL	M8	1	1.38	1.4	10.5	10.47	12.7	5.47	9.7	
				2.21	2.3						
M10 x 1.5	SL	M10	1	2.21	2.29	14	13.97	17.35	7.48	13.5	
				3.05	3.18						

(1) Achieved using steel socket head cap screws, 180 ksi / property class 12.9 with standard finish of thermal oxide and light oil.
 (2) For more information on proximity to bends and distance to other clinch hardware, see PEM® Tech Sheet C/L To Edge.

H™ Nuts And HNL™ Prevailing Torque Locknuts

- Meets prevailing torque requirements for IFI 100/107 Grade B (unified) and ANSI B18.16.1M (metric) locknuts.
- H nut is recommended for use in sheets HRB 80 / HB 150 or less.
- HNL nut is recommended for use in sheets HRB 60 / HB 107 or less.

Part Number Designation

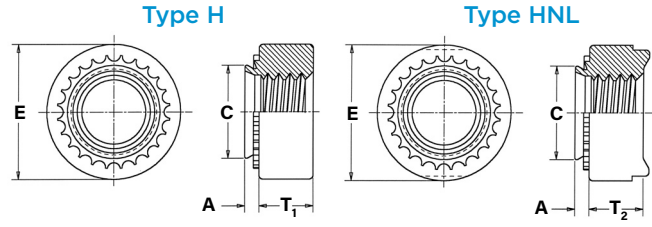
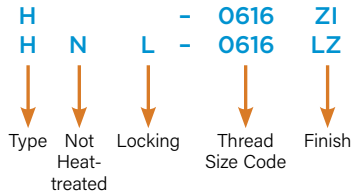

Clinching profile may vary.

All dimensions are in inches.

Unified	Thread Size	Type		Thread Code	A (Shank) Max.	Min. Sheet Thickness	Hole Size In Sheet +.005 -.000	C Max.	E ±.010	T ₁	T ₂	Min. dist. Hole C/L to Edge (2)
		Non-Locking	Self-Locking (1)							Non-locking	Self-locking	
										±.005	±.010	
	.250-20 (1/4-20)	—	HNL	0420	.058	.058	.344	.343	.500	.189		.380
	.313-18 (5/16-18)	—	HNL	0518	.058	.058	.413	.412	.575	.240		.420
	.375-16 (3/8-16)	H	HNL	0616	.058	.058	.500	.499	.650	.300		.480

All dimensions are in millimeters.

Metric	Thread Size x Pitch	Type		Thread Code	A (Shank) Max.	Min. Sheet Thickness	Hole Size In Sheet +0.13	C Max.	E ±0.25	T ₁	T ₂	Min. Dist. Hole C/L to Edge (2)
		Non-Locking	Self-Locking (1)							Non-locking	Self-locking	
										±0.13	±0.25	
	M6 x 1	—	HNL	M6	1.48	1.48	8.75	8.72	12.7	5		10
	M8 x 1.25	—	HNL	M8	1.48	1.48	10.5	10.47	14.6	6.3		11
	M10 x 1.5	H	HNL	M10	1.48	1.48	12.7	12.67	16.5	7.9		12

SH™ Hard Panel Nuts

- Installs into harder, high strength steel materials (high strength steel sheets up to 975MPa tensile strength).
- Hardened nut material provides stronger thread strength.

Part Number Designation

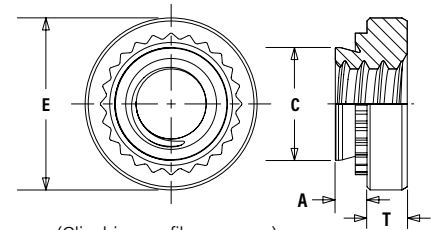
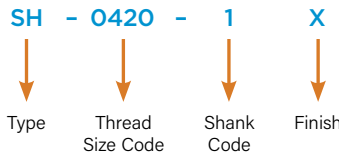

(Clinching profile may vary)
Due to manufacturing procedure, parts may have a counterbore at shank end.

All dimensions are in inches.

Unified	Thread Size	Type	Thread Code	Shank Code	A (Shank) Max.	Min. Sheet Thickness (3)	Hole Size in Sheet +.003 -.000	C Max.	E ±.010	T ±.010	Min. Dist Hole C/L To Edge (2)
		Fastener Material									
		Hardened Alloy Steel									
	.250-20 (1/4-20)	SH	0420	1	.054	.056	.344	.343	.440	.170	.34
2				.087	.090						
	.313-18 (5/16-18)	SH	0518	1	.054	.056	.413	.412	.500	.230	.38
2				.087	.090						
	.375-16 (3/8-16)	SH	0616	1	.087	.090	.500	.499	.623	.270	.44

All dimensions are in millimeters.

Metric	Thread Size x Pitch	Type	Thread Code	Shank Code	A (Shank) Max.	Min. Sheet Thickness (3)	Hole Size in Sheet +0.08	C Max.	E ±0.25	T ±0.25	Min. Dist Hole C/L To Edge (2)
		Fastener Material									
		Hardened Alloy Steel									
	M6 x 1	SH	M6	1	1.38	1.4	8.75	8.73	11.18	4.08	8.6
2				2.21	2.29						
	M8 x 1.25	SH	M8	1	1.38	1.4	10.5	10.47	12.7	5.47	9.7
2				2.21	2.29						
	M10 x 1.5	SH	M10	1	2.21	2.29	14	13.97	17.35	7.48	13.5

- During installation, the projections on the heads of HNL self-locking nuts may be flattened. This is not detrimental in any way and will not affect self-locking or self-clinching performance.
- For more information on proximity to bends and distance to other clinch hardware, see [PEM® Tech Sheet C/L To Edge](#).
- For maximum performance, we recommend that you use the maximum shank length for your sheet thickness.

SMPS™/SMPP™ Nuts

- Installs into sheets as thin as .025" / 0.64 mm.
- Reduced outer dimensions and thinner sheet capabilities compared to Type S/SP thread sizes.
- SMPS nut is recommended for use in sheets HRB 70 / HB 125 or less.
- SMPP nut is recommended for use in stainless steel sheets HRB 90 / HB 192 or less.

Part Number Designation

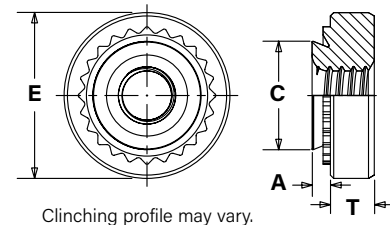
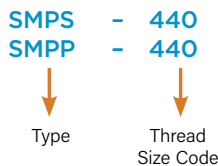

All dimensions are in inches.

Unified	Thread Size (#2-56)	Type		Thread Code	A (Shank) Max.	Min. Sheet Thickness	Hole Size In Sheet +.003 -.000	C Max.	E ±.010	T ±.010	Min. Dist. Hole C/L to Edge (1)	
		Fastener Material									SMPS	SMPP
		Stainless Steel	Hardened Stainless Steel									
	.086-56 (#2-56)	SMPS	SMPP	256	.024	.025	.136	.135	.220	.065	.15	.16
	.112-40 (#4-40)	SMPS	SMPP	440	.024	.025	.166	.165	.220	.065	.17	.20
	.138-32 (#6-32)	SMPS	SMPP	632	.024	.025	.187	.186	.252	.065	.20	.22

All dimensions are in millimeters.

Metric	Thread Size x Pitch	Type		Thread Code	A (Shank) Max.	Min. Sheet Thickness	Hole Size In Sheet +0.08	C Max.	E ±0.25	T ±0.25	Min. Dist. Hole C/L to Edge (1)	
		Fastener Material									SMPS	SMPP
		Stainless Steel	Hardened Stainless Steel									
	M2.5 x 0.45	SMPS	SMPP	M2.5	0.61	0.64	3.8	3.79	5.6	1.4	3.7	3.9
	M3 x 0.5	SMPS	SMPP	M3	0.61	0.64	4.24	4.22	5.6	1.4	4.3	5.1
	M3.5 x 0.6	SMPS	SMPP	M3.5	0.61	0.64	4.75	4.73	6.4	1.4	5.1	5.5

(1) For more information on proximity to bends and distance to other clinch hardware, see [PEM® Tech Sheet C/L To Edge](#).

Material And Finish Specifications

Type	Threads			Fastener Materials					Standard Finishes				Optional Finish	For use in Sheet Hardness (8)						
	Internal ASME B1.1 2B/ASME B1.13M, 6H	Meets Torque Requirements for IFI 100/107 Grade B (unified) and ANSI B18.16.1M (metric) Locknuts	3 Cycle Locking Performance	Hardened Carbon Steel	300 Series Stainless Steel	Aluminum	Carbon Steel	Hardened Alloy Steel	Age Hardened A286 Stainless Steel	Passivated and/or Tested per ASTM A380	Zinc Plated, per ASTM B633, SCI (5µm), Type II, Colorless (4)	Zinc Plated per ASTM B633, SCI (5µm), Type III, Colorless Plus Sealant/Lubricant (4)	No Finish (3)	Zinc Plated per ASTM B633, SCI (5µm), Type II, Yellow (1) (4)	HRC 30/ HB 277 or less	HRB 90/ HB 192 or less	HRB 80/ HB 150 or less	HRB 70/ HB 125 or less	HRB 60/ HB 107 or less	HRB 50/ HB 82 or less
S	▪			▪							▪		▪							
SS	▪			▪							▪		▪							
CLS	▪				▪					▪									▪	
CLSS	▪				▪					▪									▪	
CLA	▪					▪							▪ (2)							▪
H	▪			▪									▪							
SP	▪							▪		▪										
PEM RT	▪ (9)			▪									▪							
SL	▪		▪																	
HNL	▪	▪					▪													▪
SH	▪												▪ (5)		▪					
SMPS	▪				▪					▪										▪
SMPP	▪							▪		▪										▪ (6)(7)
Part number codes for finishes										None	ZI	LZ	X	ZC						

- (1) Special order with additional charge.
- (2) Part numbers for aluminum nuts have no plating suffix.
- (3) Unplated threads are sized to accept a basic go gauge after .00025" / 0.0064 mm plating.
- (4) See PEM® Technical Support section of our web site for related plating standards and specifications.
- (5) With rust preventative oil.
- (6) Panel material should be in the annealed condition.
- (7) Fasteners should not be installed adjacent to bends or other highly cold-worked areas.
- (8) HRB - Hardness Rockwell "B" Scale. HRC - Hardness Rockwell "C" Scale. HB - Hardness Brinell.
- (9) Modified thread form on loaded flank. Will accept a maximum material 6g/2A screw.

Installation

1. Prepare properly sized mounting hole in sheet. Do not perform any secondary operations such as deburring.
2. Place fastener into the anvil hole and place the mounting hole (preferably the punch side) over the shank of the fastener.
3. With installation punch and anvil surfaces parallel, apply squeezing force until the head of the nut comes into contact with the sheet material.

Installation Tooling⁽¹⁾

CLS™/CLSS™/S™/SS™/PEM RT® Nuts

Unified	Thread Code	HAEGER® Part Number		PEMSERTER® Part Number		Anvil Dimensions (in.)	
		Anvil	Punch	Anvil	Punch	A ±.002	P ±.005
	256/440/RT440	H-101-2-4/M3L	H-108-0020L	975200034	975200048	.267	.045
	632/RT632	H-101-6/M3.5L	H-108-0020L	975200035	975200048	.298	.045
	832/RT832	H-101-8/M4L	H-108-0020L	975200036	975200048	.330	.070
	024/032/RT032	H-101-10-M5L	H-108-0020L	975200037	975200048	.361	.070
	1224	—	—	975200786300	975200048	.415	.080
	0420/RT0420	H-101-04/M6L	H-108-0020L	975200038	975200048	.454	.150
	0518/RT0518	H-101-05/M8L	H-108-0020L	975200039	975200048	.517	.200
	0616	10-00303	H-108-0020L	975200045 (1)	975200048	.280	.250
	0720	—	—	8020361 (1)	975200901400	.338	.295
	0813	10-00305	H-108-00020L	975200900300 (1)	975200901400	.375	.345

Metric	Thread Code	HAEGER® Part Number		PEMSERTER® Part Number		Anvil Dimensions (mm)	
		Anvil	Punch	Anvil	Punch	A ±0.05	P ±0.13
	M2/M2.5/M3/RTM3	H-101-2-4/M3L	H-108-0020L	975200034	975200048	6.78	1.14
	M3.5	H-101-6/M3.5L	H-108-0020L	975200035	975200048	7.57	1.14
	M4/RTM4	H-101-8/M4L	H-108-0020L	975200036	975200048	8.38	1.78
	M5/RTM5	H-101-10-M5L	H-108-0020L	975200037	975200048	9.17	1.78
	M6/RTM6	H-101-04/M6L	H-108-0020L	975200038	975200048	11.53	3.81
	M8/RTM8	H-101-05/M8L	H-108-0020L	975200039	975200048	13.08	5.08
	M10	10-00301	H-108-0020L	8005682 (1)	975200901400	7.62	6.35
	M12	10-00305	H-108-0020L	975200900300 (1)	975200901400	9.53	8.76

Counterbore Anvil

Thread Sizes #2-56 to 5/16 and M2 to M8

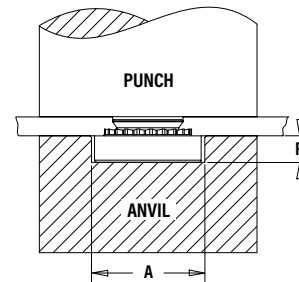

CLTA™ Nuts

Unified	Thread Code	HAEGER® Part Number		PEMSERTER® Part Number		Anvil Dimensions (in.)	
		Anvil	Punch	Anvil	Punch	A ±.002	P ±.005
	256	H-101-2-4/M3L	H-108-0020L	975200034	975200048	.267	.045
	440	H-101-2-4/M3L	H-108-0020L	975200034	975200048	.267	.045
	632	H-101-6/M3.5L	H-108-0020L	975200035	975200048	.298	.045
	832	H-101-8/M4L	H-108-0020L	975200036	975200048	.330	.070
	024	H-101-10-M5L	H-108-0020L	975200782300	975200048	.392	.140
	032	H-101-10-M5L	H-108-0020L	975200782300	975200048	.392	.140
	0420	H-101-04/M6L	H-108-0020L	975200038	975200048	.454	.150

Metric	Thread Code	HAEGER® Part Number		PEMSERTER® Part Number		Anvil Dimensions (mm)	
		Anvil	Punch	Anvil	Punch	A ±0.05	±0.13
	M3	H-101-2-4/M3L	H-108-0020L	975200034	975200048	6.78	1.14
	M3.5	H-101-6/M3.5L	H-108-0020L	975200035	975200048	7.57	1.14
	M4	H-101-8/M4L	H-108-0020L	975200036	975200048	8.38	1.78
	M5	H-101-10-M5L	H-108-0020L	975200782300	975200048	9.96	3.56
	M6	H-101-04/M6L	H-108-0020L	975200038	975200048	11.53	3.81

Protrusion Anvil (1)

CLS/S/SL/S-RT Thread Sizes 3/8, 7/16, 1/2, M10 and M12
H/HNL Thread Sizes 5/16, 3/8, M8 and M10

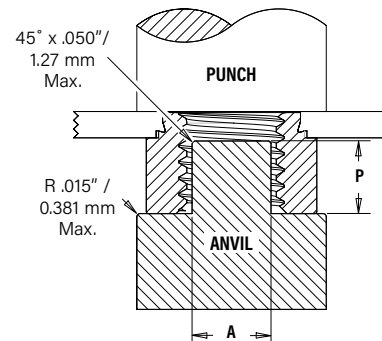

SMPS™ Nuts

Unified	Thread Code	HAEGER® Part Number		PEMSERTER® Part Number		Anvil Dimensions (in.)	
		Anvil	Punch	Anvil	Punch	A ±.002	P ±.005
	256	10-00278	H-108-0020L	975200904300	975200048	.236	.045
	440	10-00279	H-108-0020L	975200904300	975200048	.236	.045
	632	H-101-2-4/M3L	H-108-0020L	975200034	975200048	.267	.045

Metric	Thread Code	HAEGER® Part Number		PEMSERTER® Part Number		Anvil Dimensions (mm)	
		Anvil	Punch	Anvil	Punch	A ±0.05	P ±0.13
	M2.5	10-00292	H-108-0020L	975200904300	975200048	5.99	1.14
	M3	10-00293	H-108-0020L	975200904300	975200048	5.99	1.14
	M3.5	H-101-2-4/M3L	H-108-0020L	975200034	975200048	6.78	1.14

Installation Notes

- For best results we recommend using a HAEGER® or PEMSERTER® machine for installation of PEM® self-clinching fasteners. See our website for more information.
- Visit the [Animation Library](#) on our website to view the installation process.

(1) Large nut anvils use protrusion to locate part instead of counterbore.

SL™ Nuts

Unified	Thread Code	HAEGER® Part Number		PEMSERTER® Part Number		Anvil Dimensions (in.)	
		Anvil	Punch	Anvil	Punch	A ±.002	P ± .005
	440	H-101-2-4/M3L	H-108-0020L	975200034	975200048	.267	.045
632	H-101-6/M3.5L	H-108-0020L	975200035	975200048	.298	.045	
832	H-101-8/M4L	H-108-0020L	975200036	975200048	.330	.070	
032	H-101-10-M5L	H-108-0020L	975200037	975200048	.361	.070	
0420	H-101-04/M6L	H-108-0020L	975200038	975200048	.454	.150	
0518	H-101-05/M8L	H-108-0020L	975200039	975200048	.515	.200	

Metric	Thread Code	HAEGER® Part Number		PEMSERTER® Part Number		Anvil Dimensions (mm)	
		Anvil	Punch	Anvil	Punch	A ±0.05	P ±0.13
	M3	H-101-2-4/M3L	H-108-0020L	975200034	975200048	6.78	1.14
M3.5	H-101-6/M3.5L	H-108-0020L	975200035	975200048	7.57	1.14	
M4	H-101-8/M4L	H-108-0020L	975200036	975200048	8.38	1.78	
M5	H-101-10-M5L	H-108-0020L	975200037	975200048	9.17	1.78	
M6	H-101-04/M6L	H-108-0020L	975200038	975200048	11.53	3.81	
M8	H-101-05/M8L	H-108-0020L	975200039	975200048	13.08	5.08	
M10	10-00301	H-108-0020L	8005682 ⁽¹⁾	975200901400	7.62	6.35	

H™/HNL™ Nuts

Unified	Thread Code	HAEGER® Part Number		PEMSERTER® Part Number		Anvil Dimensions (in.)	
		Anvil	Punch	Anvil	Punch	A ±.002	P ±.005
	0420	10-00283	H-108-0020L	975200039	975200048	5.17	.200
0518	10-00284	H-108-0020L	975200783300 ⁽¹⁾	975200048	.220	.250	
0616	10-00303	H-108-0020L	975201240 ⁽¹⁾	8003076	.280	.250	

Metric	Thread Code	HAEGER® Part Number		PEMSERTER® Part Number		Anvil Dimensions (mm)	
		Anvil	Punch	Anvil	Punch	A ±0.05	P ±0.13
	M6	10-00297	H-108-0020L	975200039	975200048	13.13	5.08
M8	10-00298	H-108-0020L	975200783300 ⁽¹⁾	975200048	5.59	6.35	
M10	10-00301	H-108-0020L	8005682 ⁽¹⁾	8003076	7.62	6.35	

Counterbore Anvil

Thread Sizes 1/4-20 to 5/16 and M5 to M8

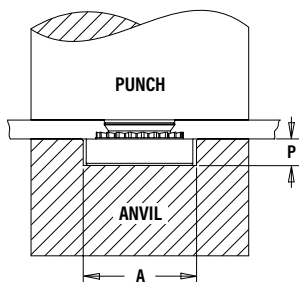

Protrusion Anvil

Thread Sizes 3/8 and M10

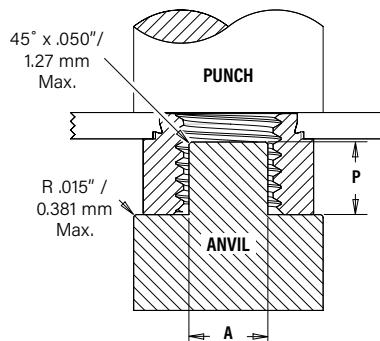

SH™ Nuts

Unified	Thread Code	HAEGER® Part Number		PEMSERTER® Part Number		Anvil Dimensions (in.)	
		Anvil	Punch	Anvil	Punch	A ±.002	P ± .005
	0420	H-101-04/M6L	H-108-0020L	975200038	975200048	.454	.150
0518	H-101-05/M8L	H-108-0020L	975200039	975200048	.517	.200	
0616	10-00303	H-108-0020L	8020084 ⁽¹⁾	9752000901400	.280	.250	

Metric	Thread Code	HAEGER® Part Number		PEMSERTER® Part Number		Anvil Dimensions (mm)	
		Anvil	Punch	Anvil	Punch	A ±0.05	P ±0.13
	M6	H-101-04/M6L	H-108-0020L	975200038	975200048	11.53	3.81
M8	H-101-05/M8L	H-108-0020L	975200039	975200048	13.13	5.08	
M10	10-00301	H-108-0020L	8005682 ⁽¹⁾	8003076	7.62	6.35	

(1) Large nut anvils use protrusion to locate part instead of counterbore.

SP™ NUTS

Unified	Thread Code	HAEGER® Part Number		PEMSERTER® Part Number		Anvil Dimensions (in.)			
		Lower Tool	Upper Tool	Anvil	Punch	A ±.002	P +.000 -.001	R Max.	R1 +.005
	440	H-183-4/M3-L	H-108-0020L	8012821	975200048	.255	.064	.010	.005
	632	H-183-6/M3.5-L	H-108-0020L	8012822	975200048	.286	.064	.010	.005
	832	H-183-8/M4-L	H-108-0020L	8012823	975200048	.317	.082	.010	.005
	024/032	H-183-10/M5-L	H-108-0020L	8012824	975200048	.348	.082	.010	.005
	0420	H-183-04/M6-L	H-108-0020L	8012825	8003076	.443	.163	.010	.005
	0518	—	—	8015359	8003076	.505	.230	.010	.005
	0616/0624	—	—	8015863	8003076	.570	.263	.010	.005

Metric	Thread Code	HAEGER® Part Number		PEMSERTER® Part Number		Anvil Dimensions (mm)			
		Lower Tool	Upper Tool	Anvil	Punch	A ±0.05	P -0.03	R Max.	R1 +0.13
	M2	—	—	8012821	975200048	6.48	1.63	0.25	0.13
	M2.5-0	—	—	8019477	975200048	6.48	1.42	0.25	0.13
	M2.5-1,-2	—	—	8012821	975200048	6.48	1.63	0.25	0.13
	M3	H-183-4/M3-L	H-108-0020L	8012821	975200048	6.48	1.63	0.25	0.13
	M3.5	H-183-6/M3.5-L	H-108-0020L	8012822	975200048	7.26	1.63	0.25	0.13
	M4	H-183-8/M4-L	H-108-0020L	8012823	975200048	8.05	2.08	0.25	0.13
	M5	H-183-10/M5-L	H-108-0020L	8012824	975200048	8.84	2.08	0.25	0.13
	M6	H-183-04/M6-L	H-108-0020L	8012825	8003076	11.25	4.14	0.25	0.13
	M8	—	—	8015360	8003076	12.83	5.41	0.25	0.13
	M10	—	—	8015886	8003076	17.58	7.47	0.25	0.13

Recommended Counterbore Anvil

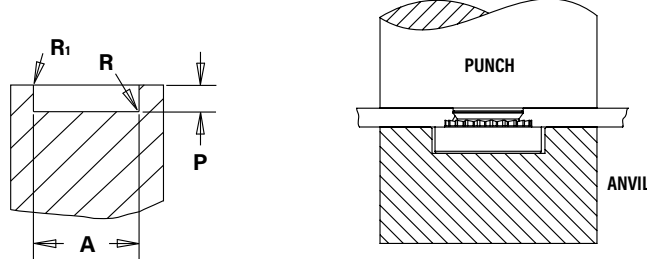

SMPP™ Nuts

Unified	Thread Code	HAEGER® Part Number		PEMSERTER® Part Number		Anvil Dimensions (in.)			
		Lower Tool	Upper Tool	Anvil	Punch	A ±.002	P +.000 -.001	R Max.	R1 +.005
	256	10-00278	H-108-0020L	8020023	975200048	.223	.060	.010	.005
	440	10-00279	H-108-0020L	8021386	975200048	.233	.060	.010	.005
	632	10-00280	H-108-0020L	8020024	975200048	.255	.060	.010	.005

Metric	Thread Code	HAEGER® Part Number		PEMSERTER® Part Number		Anvil Dimensions (mm)			
		Lower Tool	Upper Tool	Anvil	Punch	A ±0.05	P -0.03	R Max.	R1 +0.13
	M2.5	10-00292	H-108-0020L	8020025	975200048	5.66	1.27	0.25	0.13
	M3	10-00293	H-108-0020L	8021474	975200048	5.9	1.27	0.25	0.13
	M3.5	10-00294	H-108-0020L	8020026	975200048	6.48	1.27	0.25	0.13

(1) For best results, we recommend using the recommended installation punch and anvil. Deviations from recommended installation tooling may result in sheet distortion and reduced performance.

NOTE: Variations in hole preparation, installation tooling, installation force, and sheet material type, thickness, and hardness will affect both performance and tooling life.



For Additional HAEGER® and PEMSERTER® Tooling Information/Part Numbers visit our [tooling wizard](#)



Performance Data⁽¹⁾

Click here for Axial Strength and Mating Screw Recommended Tightening Torque data
See our [techsheet](#) for performance data of PEM fasteners installed into copper.

S™/CLS™/CLSS™ Nuts

Unified	Type	Thread Code	Shank Code	Test Sheet Material (2)	Installation (lbs.)	Pushout (lbs.)	Torque-out (in. lbs.)
	S CLS	256 348 440	5052-H34 Aluminum	0	1500-2000	63	8
1				90		10	
2				170		13	
3			170	13			
Cold-rolled Steel			0	105		13	
			1	125		15	
		2	230	18			
S CLS		632	5052-H34 Aluminum	0	2500-3000	63	16
				1		95	17
				2		190	22
			3	190		22	
			Cold-rolled Steel	0		110	16
	1			130		20	
	2	275		28			
	S CLS	832	5052-H34 Aluminum	0	2500-3000	68	21
				1		105	23
				2		220	35
			3	220		35	
			Cold-rolled Steel	0		110	26
1				145		35	
2		285		45			
SS CLSS		024 032	5052-H34 Aluminum	0	2500-3500	68	26
				1		110	32
				2		190	50
			3	225		50	
			Cold-rolled Steel	0		120	32
	1			180		40	
	2	320		60			
	S CLS	1224	5052-H34 Aluminum	1	2500-6500	120	63
				2		285	70
				3		285	70
			Cold-rolled Steel	1		200	74
				2		350	80
3				350		80	
S CLS		0420	5052-H34 Aluminum	0	4000-7000	220	70
				1			90
				2		360	125
			3				
			Cold-rolled Steel	0		315	115
				1			
	2	400		150			
	S CLS	0518 0524	5052-H34 Aluminum	1	4000-7000		120
				2			160
				3			165
			Cold-rolled Steel	1			180
				2			
3							
S CLS		0616 0624	5052-H34 Aluminum	1	5000-8000		270
				2			
				3			
		Cold-rolled Steel	1		320		
			2				
			3				
S	0720	1	Cold-rolled Steel	9000-13000	450	340	
S CLS	0813 0820	5052-H34 Aluminum	1	10000-15000		350	
			2				
		Cold-rolled Steel	1			735	
			2				

Metric	Type	Thread Code	Shank Code	Test Sheet Material (2)	Installation (kN)	Pushout (N)	Torque-out (N-m)			
	S CLS	M2 M2.5 M3	5052-H34 Aluminum	0	6.7-8.9	280	0.9			
1				400		1.13				
2				750		1.47				
Cold-rolled Steel			0	470		1.47				
			1	550		1.7				
			2	1010		2.03				
S CLS		M3.5	5052-H34 Aluminum	0	11.2-13.5	280	1.8			
				1		400	1.92			
				2		840	2.5			
		Cold-rolled Steel	0	480		1.8				
			1	570		2.3				
			2	1210		2.3				
S CLS		M4	5052-H34 Aluminum	0	11.2-13.4	300	2.37			
				1		470	2.6			
				2		970	4			
		Cold-rolled Steel	0	490		2.95				
			1	645		4				
			2	1250		5.1				
SS CLSS		M5	5052-H34 Aluminum	0	11.2-15.6	300	3			
				1		480	3.6			
				2		845	5.7			
			Cold-rolled Steel	0		530	3.6			
				1		800	4.5			
				2		1420	6.8			
	S CLS	M6	5052-H34 Aluminum	00	18-32	750	6.5			
				0		970	7.9			
				1		1580	10.2			
			Cold-rolled Steel	2		14.1				
				00		900	10			
				0		1380	13			
S CLS		M8	5052-H34 Aluminum	1	18-32	1570	13.6			
				2		18.1				
				1		18.7				
		Cold-rolled Steel	2	1870		20.3				
			S CLS	M10		5052-H34 Aluminum	1	22-36	1760	32.7
							2			
1	32-50	2020			36.2					
S	M12	5052-H34 Aluminum	1	31-40	2113	39.5				
			1		Cold-rolled Steel	44-67	4670		83.1	

CLA™ Nuts

Unified	Type	Thread Code	Shank Code	Test Sheet Material	Installation (lbs.)	Pushout (lbs.)	Torque-out (in. lbs.)
	CLA	440	5052-H34 Aluminum	1	800 - 1500	100	6
2				800 - 1500	120	9	
632		5052-H34 Aluminum	1	1000 - 1500	110	21	
			2	1200 - 1700	155	24	
832		5052-H34 Aluminum	1	1000 - 1500	120	27	
			2	1300 - 1800	170	29	
032		5052-H34 Aluminum	1	1700 - 2200	130	34	
			2	2600 - 3100	200	50	

Metric	Type	Thread Code	Shank Code	Test Sheet Material	Installation (kN)	Pushout (N)	Torque-out (N-m)
	CLA	M2	5052-H34 Aluminum	2	3.56 - 6.67	500	0.4
1				3.56 - 6.67	445	0.68	
M3		5052-H34 Aluminum	2	3.56 - 6.67	534	1.02	
			1	4.45 - 6.67	534	3.05	
M4		5052-H34 Aluminum	1	5.78 - 8.01	756	3.27	

(1) Published installation forces are for general reference. Actual set-up and confirmation of complete installation should be made by observing proper seating of fastener as described in the installation steps. Other performance values reported are averages when all proper installation parameters and procedures are followed. Variations in mounting hole size, sheet material, and installation procedure may affect performance. Performance testing this product in your application is recommended. We will be happy to provide technical assistance and/or samples for this purpose.
(2) See [tech sheet](#) on our website for performance data of PEM® Type S™ nuts installed into copper sheets.

Performance Data⁽¹⁾

Click here for Axial Strength and Mating Screw Recommended Tightening Torque data
See our [techsheet](#) for performance data of PEM fasteners installed into copper.

PEM RT® Nuts

Unified	Type	Thread Code	Shank Code	Test Sheet Material	Installation (lbs.)	Pushout (lbs.)	Torque-out (in. lbs.)
	S	RT440		0	5052-H34 Aluminum	1500-2000	63
1				90			10
2				170			13
0				Cold-rolled Steel	105		13
1					125		15
2					230		18
S	RT632		0	5052-H34 Aluminum	2500-3000	63	16
			1			95	17
			2			190	22
			0	Cold-rolled Steel		110	16
			1			130	20
			2			275	28
S	RT832		0	5052-H34 Aluminum	2500-3000	68	21
			1			105	23
			2			220	35
			0	Cold-rolled Steel		110	26
			1			145	35
			2			285	45
SS	RT032		0	5052-H34 Aluminum	2500-3500	68	26
			1			110	32
			2			190	50
			0	Cold-rolled Steel		120	32
			1			180	40
			2			320	60
S	RT0420		0	5052-H34 Aluminum	4000-7000	220	70
			1			360	90
			2			125	125
			0	Cold-rolled Steel		315	115
			1			400	150
			2				
S	RT0518		1	5052-H34 Aluminum	4000-7000	380	120
			2			160	160
			1			165	165
			2	Cold-rolled Steel		420	180
			1				
			2				

Metric	Type	Thread Code	Shank Code	Test Sheet Material	Installation (kN)	Pushout (N)	Torque-out (N-m)	
	S	RTM3		0	5052-H34 Aluminum	6.7-8.9	280	0.9
1				400			1.13	
2				750			1.47	
0				Cold-rolled Steel	470		1.47	
1					550		1.7	
2					1010		2.03	
S		RTM4		0	5052-H34 Aluminum	11.2-13.4	300	2.37
				1			470	2.6
				2			970	4
				0	Cold-rolled Steel		490	2.95
				1			645	4
				2			1250	5.1
SS	RTM5		0	5052-H34 Aluminum	11.2-15.6	300	3	
			1			480	3.6	
			2			845	5.7	
			0	Cold-rolled Steel		530	3.6	
			1			800	4.5	
			2			1420	6.8	
S	RTM6		00	5052-H34 Aluminum	18-32	750	6.5	
			0			970	7.9	
			1			1580	10.2	
			2	Cold-rolled Steel		900	10	
			0			1380	13	
			1			1760	17	
	S	RTM8		1	5052-H34 Aluminum	18-32	1690	13.6
				2			18.1	
				1			18.7	
				2	Cold-rolled Steel		1865	20.3
				1				
				2				

SL™ Nuts

Unified	Thread Code	Shank Code	Prevailing Torque Specifications (1)		Test Sheet Material					
			Max. Torque (1st thru 3rd) (in. lbs.)	Min. Torque (1st thru 3rd) (in. lbs.)	5052-H34 Aluminum			Cold-rolled Steel		
					Installation (lbs.)	Pushout (lbs.)	Torque-out (in. lbs.)	Installation (lbs.)	Pushout (lbs.)	Torque-out (in. lbs.)
440	1	2	5.75	0.4	1500 - 2000	90	10	2500 - 3500	125	15
						170	13		230	18
632	1	2	10.5	0.8	2500 - 3000	95	17	3000 - 6000	130	20
						190	22		275	28
832	1	2	18	1.2	2500 - 3000	105	23	4000 - 6000	145	35
						220	35		285	45
032	1	2	21	1.65	2500 - 3000	110	32	4000 - 9000	180	40
						190	50		250	60
0420	1	2	35	3.75	4000 - 7000	360	90	6000 - 9000	400	150
						360	125		400	150
0518	1	2	53	4.75	4000 - 7000	380	120	6000 - 8000	420	165
						380	160		420	180

Metric	Thread Code	Shank Code	Prevailing Torque Specifications (1)		Test Sheet Material					
			Max. Torque (1st thru 3rd) (N-m)	Min. Torque (1st thru 3rd) (N-m)	5052-H34 Aluminum			Cold-rolled Steel		
					Installation (kN)	Pushout (N)	Torque-out (N-m)	Installation (kN)	Pushout (N)	Torque-out (N-m)
M3	1	2	0.67	0.04	6.7 - 8.9	400	1.13	11.2 - 15.6	550	1.7
						750	1.47		1010	2.03
M3.5	1	2	1.2	0.08	11.2 - 13.5	400	1.92	13.4 - 26.7	570	2.3
						840	2.5		1210	2.3
M4	1	2	2.1	0.13	11.2 - 13.4	470	2.6	18 - 27	645	4
						970	4		1250	5.1
M5	1	2	2.4	0.18	11.2 - 15.6	480	3.6	18 - 38	800	4.5
						845	5.7		1112	6.8
M6	1	2	4	0.3	18 - 32	1580	10.2	27 - 36	1760	17
						1580	14.1		1760	17
M8	1	2	6	0.5	18 - 32	1570	13.6	27 - 36	1870	18.7
						1570	18.1		1870	20.3
M10	1	2	12	0.8	22 - 36	1760	32.7	32 - 50	2020	36.2
						1760	32.7		2020	36.2

(1) 3 cycle locking performance. Max. on / Min. off torque for 1st through 3rd cycles.

Performance Data⁽¹⁾

Click [here](#) for Axial Strength and Mating Screw Recommended Tightening Torque data
See our [techsheet](#) for performance data of PEM fasteners installed into copper.

SP™ Nuts

Unified	Type	Thread Code	Shank Code	Test Sheet Material	Installation (lbs.)	Pushout (lbs.)	Torque-out (in. lbs.)
	SP	256	0	304 Stainless Steel	8000	130	14
			1		9000	165	17
			2		10000	290	18
	SP	440	0	304 Stainless Steel	8000	130	14
			1		9000	165	17
			2		10000	290	18
	SP	632	0	304 Stainless Steel	8500	140	18
			1		9500	170	24
			2		10500	340	28
	SP	832	0	304 Stainless Steel	9000	145	30
			1		10000	180	37
			2		11000	360	45
	SP	024/032	0	304 Stainless Steel	9500	180	35
			1		10500	230	45
2			11500		400	60	
SP	0420	1	304 Stainless Steel	13500	450	150	
		2		13500	600	170	
SP	0518	1	304 Stainless Steel	14800	470	170	
		2		18000	750	250	
SP	0524	1	304 Stainless Steel	14800	470	170	
		2		18000	750	250	
SP	0616/0624	1	304 Stainless Steel	16000	600	300	
		2		20000	700	370	

Metric	Type	Thread Code	Shank Code	Test Sheet Material	Installation (kN)	Pushout (N)	Torque-out (N-m)
	SP	M2	1	304 Stainless Steel	40	725	1.92
			2		44.5	1290	2.03
	SP	M2.5	0	304 Stainless Steel	35.6	575	1.58
			1		40	725	1.92
			2		44.5	1290	2.03
	SP	M3	0	304 Stainless Steel	35.6	575	1.58
			1		40	725	1.92
			2		44.5	1290	2.03
	SP	M4	0	304 Stainless Steel	40	645	3.38
			1		44.5	800	4.18
			2		49	1600	5.08
	SP	M5	0	304 Stainless Steel	42.3	800	3.95
			1		46.7	1025	5.08
			2		51.2	1775	6.77
SP	M6	1	304 Stainless Steel	60	2000	17	
		2		60	2600	19	
SP	M8	1	304 Stainless Steel	66	2100	19	
		2		80	4500	23	
SP	M10	1	304 Stainless Steel	80	2150	38	

H™ Nuts

Unified	Type	Thread Code	Test Sheet Thickness and Sheet Material	Installation (lbs.)	Pushout (lbs.)	Torque-out (in. lbs.)
	H	0616	.090" 5052-H34 Aluminum	4900	380	190
			.088" Cold-rolled Steel	7400	460	240

Metric	Type	Thread Code	Test Sheet Thickness and Sheet Material	Installation (kN)	Pushout (N)	Torque-out (N-m)
	H	M10	2.29 mm 5052-H34 Aluminum	22	1760	21.5
			2.24 mm Cold-rolled Steel	33	2020	271

SH™ Nuts

Unified	Thread Code	Shank Code	Test Sheet Thickness and Material (in.)	Sheet Hardness HRC	Installation (lbs.)	Pushout (lbs.)	Torque-out (in. lbs.)
	0420	1	.098" S700MC	23	11700	950	150
		2	.098" S700MC	23	12900	1000	170
	0518	1	.098" S700MC	23	12600	1050	265
		2	.098" S700MC	23	12900	1100	265
0616	1	.098" S700MC	23	15300	1200	500	

Metric	Thread Code	Shank Code	Test Sheet Thickness and Material (mm)	Sheet Hardness HRC	Installation (kN)	Pushout (N)	Torque-out (N-m)
	M6	1	2.5 mm S700MC	23	52.1	4200	17
		2	2.5 mm S700MC	23	57.4	4500	19
	M8	1	2.5 mm S700MC	23	56.1	4600	30
		2	2.5 mm S700MC	23	57.4	4900	30
M10	1	2.5 mm S700MC	23	71.2	5400	56	

Performance Data⁽¹⁾

[Click here](#) for Axial Strength and Mating Screw Recommended Tightening Torque data
See our [techsheet](#) for performance data of PEM fasteners installed into copper.

SMPS™ Nuts

Unified	Type	Thread Code	Test Sheet Material		
			Cold-rolled Steel		
			Installation (lbs.)	Pushout (lbs.)	Torque-out (in. lbs.)
SMPS	256	1500	35	8	
SMPS	440	1800	60	12	
SMPS	632	2000	65	14	

Metric	Type	Thread Code	Test Sheet Material		
			Cold-rolled Steel		
			Installation (kN)	Pushout (N)	Torque-out (N-m)
SMPS	M2.5	6.7	156	1.13	
SMPS	M3	8	267	1.35	
SMPS	M3.5	8.8	289	1.58	

SMPP™ Nuts

Unified	Type	Thread Code	Test Sheet Material		
			.029" 304 Stainless Steel HRB 89		
			Installation ⁽¹⁾ (lbs.)	Pushout (lbs.)	Torque-out (in. lbs.)
SMPP	256	4500	50	10	
SMPP	440	4500	75	15	
SMPP	632	6000	75	20	

Metric	Type	Thread Code	Test Sheet Material		
			0.7 mm 304 Stainless Steel HRB 89		
			Installation ⁽¹⁾ (kN)	Pushout (N)	Torque-out (N-m)
SMPP	M2.5	20	200	1.35	
SMPP	M3	20	300	1.85	
SMPP	M3.5	27	300	1.9	

(1) Installation controlled by proper cavity depth in installation tooling.

See our [techsheet](#) for performance data of PEM fasteners installed into copper.

Pushout Test

Pushout tests shall be performed from the grip or shank side of the installed fastener. An axial load shall be applied to the fastener as shown using a hardened test screw, while evenly supporting the test strip around the fastener. The typical position rate is .25" / 6.35 mm per minute. Dimensions are identified per PEM Bulletins where "E" equals head diameter and "T" (or "L") equals head height. The pushout force is measured using a force or compression tester with a range that will cover the expected forces.

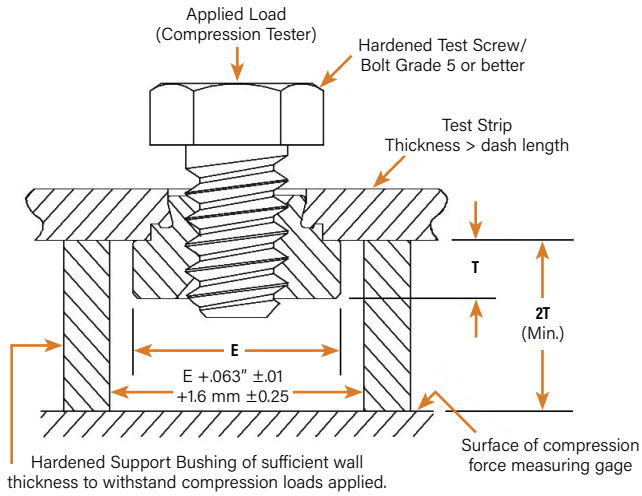

Torque-Out Test

Torque-out tests shall be performed from the shoulder or head side of the installed fastener. Torque shall be applied to the fastener in the manner illustrated, using a hardened test screw and washer, while firmly holding the test strip. Test screws should be of sufficient tensile strength to resist thread stripping. A minimum of two screw threads must extend beyond the fastener.

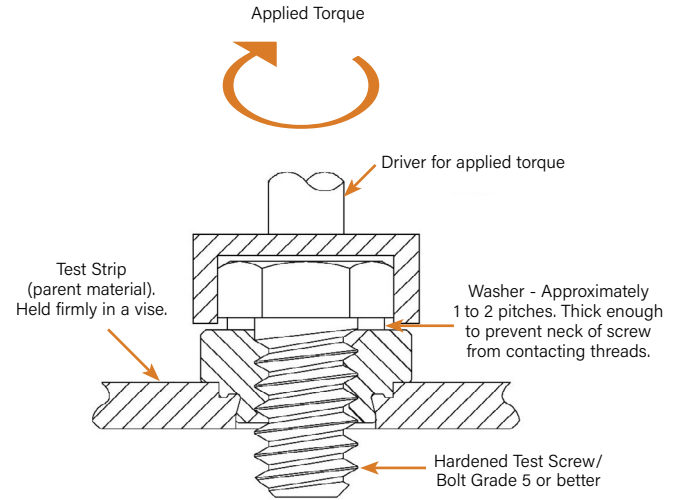

Self-Piercing, Self-Clinching Tooling

Specialized PEMSERTER® tooling allows installation of S self-clinching nuts into aluminum sheets (sizes 1/4", 5/16", M6 and M8) in one pierce/press operation.

For more information, see our web site for Tech Sheet [PEM® - Ref / Self-piercing, self-clinching tooling](#).
To locate, simply type "self-piercing" in site search box.

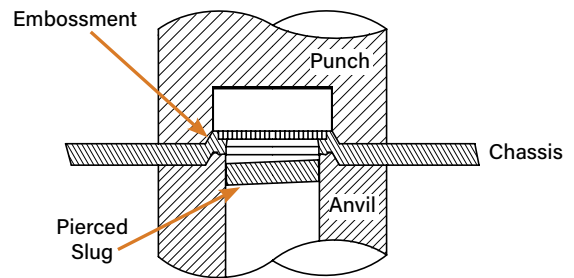

Self-Clinching Nut Installation Dos And Don'ts

"DOS"

- DO** select the proper fastener material to meet corrosion requirements.
- DO** make certain that panel material is in the annealed condition.
- DO** make certain that hole punch is kept sharp to minimize work hardening around hole.
- DO** provide mounting hole of specified size for each fastener.
- DO** maintain the hole punch diameter to no greater than $+.001"/.025$ mm over the minimum recommended mounting hole for type SP nuts into stainless steel sheets.
- DO** install fastener into hole punch side of sheet.
- DO** make certain that shank (or pilot) is within hole before applying installation force.
- DO** make certain that fastener is not installed adjacent to bends or other highly cold-worked areas.
- DO** apply squeezing force between parallel surfaces.
- DO** utilize recommended installation tooling when installing fasteners.
- DO** apply sufficient force to totally embed clinching ring around entire circumference and to bring shoulder squarely in contact with sheet.

"DON'TS"

- DON'T** attempt to install any self-clinching nut other than types SP/SMPP fasteners into a stainless steel sheet.
- DON'T** install steel or stainless steel fasteners in aluminum panels before anodizing or finishing.
- DON'T** deburr mounting holes on either side of sheet before installing fasteners – deburring will remove metal required for clinching fastener into sheet.
- DON'T** install fastener closer to edge of sheet than minimum edge distance indicated by manufacturer – unless a special fixture is used to restrict bulging of sheet edge.
- DON'T** over-squeeze. It will crush the head, distort threads, and buckle the sheet. Approximate installation forces are listed in performance data tables. Use this info as a guide. Be certain to determine optimum installation force by test prior to production runs.
- DON'T** attempt to insert fastener with a hammer blow – under any circumstances. A hammer blow won't permit the sheet metal to flow and develop an interlock with the fastener's contour.
- DON'T** install screw in the head side of fastener. Install from opposite side so that the fastener load is toward sheet. The clinching force is designed only to hold the fastener during handling and to resist torque during assembly.
- DON'T** install fastener on pre-painted side of panel.

All PEM® products meet our stringent quality standards. If you require additional industry or other specific [quality certifications](#), special procedures and/or part numbers are required. Please contact your local sales office or representative for further information.

Regulatory [compliance information](#) is available in Technical Support section of our website. Specifications subject to change without notice. See our website for the most current version of this bulletin.



North America: Danboro, Pennsylvania USA | E-mail: info@pemnet.com | Tel: +1-215-766-8853 | 800-237-4736 (USA)

Europe: Galway, Ireland | E-mail: europa@pemnet.com | Tel: +353-91-751714

Asia/Pacific: Singapore | E-mail: singapore@pemnet.com | Tel: +65-6-745-0660

Kunshan, China: E-mail: salesgreaterchina@pemnet.com | Tel: +86-512-5726-9300

Visit our PEMNET™ Resource Center at www.pemnet.com • Technical support e-mail: techsupport@pemnet.com