

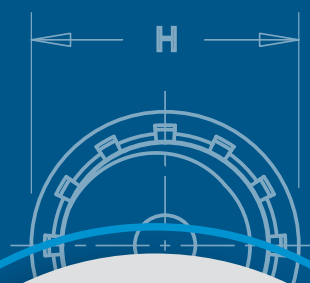

SSTM

FASTENERS FOR USE IN STAINLESS STEEL SHEETS

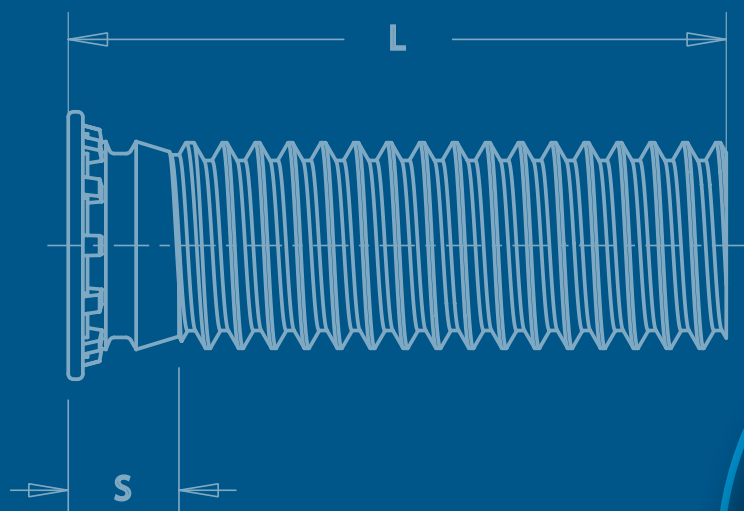

These PEM® fasteners install permanently; reduce hardware; and promote thinner and lighter designs in stainless applications.

One of the very basics of self-clinching is that the fastener must always be harder than the host sheet to ensure proper and permanent installation. This is particularly challenging when installing fasteners into stainless steel sheets. Therefore we have developed this line of specially hardened stainless steel fasteners for installation into stainless steel. **Refer to "Dos and Don'ts" on page 27 for further information.**

Fasteners made from precipitation hardened grade stainless including A286 stainless are particularly useful in applications such as outdoor equipment, medical devices and chemical and food processing equipment or anywhere corrosive element exposure is possible.

Fastener drawings and models are available at www.pemnet.com. Custom sizes are available on special order. [Contact us](#) for more information.

SP™ PEM 300® nuts provide **strong load-bearing internal threads** in stainless steel sheets as thin as .030"/0.8mm -
— [PAGE 3](#)



FH4™ and FHP™ studs offer **externally threaded attachment points** in two stainless materials, depending on the level of corrosion resistance required. (See page 24 for other non-clinching stud solutions) — [PAGE 10](#)



SMPP™ nuts install into stainless steel sheets as thin as .025"/0.64mm. Reduced outer dimensions and thinner sheet capabilities compared to Type SP thread sizes — [PAGE 4](#)



SGPC™ Swaging Collar Studs can install into most panel material and accommodate multiple panels as long as the total thickness does not exceed the maximum sheet thickness — [PAGE 11](#)



A4™ and LA4™ internally threaded floating nuts allow for **mating hole misalignment** and **locking threads** if desired. — [PAGE 5](#)



TP4™ pins provide an **unthreaded solution** for a wide range of positioning, pivot and alignment applications. — [PAGE 12](#)



F4™ fasteners are ideal for flush applications where a stainless steel sheet requires load-bearing threads — [PAGE 6](#)



PFC4™ captive panel screws provides a tool only, **captive screw solution** for stainless steel sheets. (See page 24 for other non-clinching captive screw solutions) — [PAGE 13](#)



SO4™ and BSO4™ standoffs provide internally threaded fasteners for **stacking or spacing** applications — [PAGE 7-8](#)

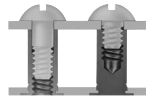

SFP™ SpotFast® fasteners provide a solution for **flush "face-on-face" sheet attachment** in stainless steel — [PAGE 14](#)



TSO4™ through hole threaded standoffs for **clinching into thinner sheets** than Type SO4. Install into sheets as thin as .025"/0.63mm. Also, threaded at the barrel end minimizing length of screw required — [PAGE 9](#)

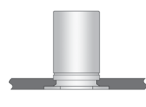

Material and finish specifications — [PAGE 15](#)

Installation — [PAGE 16-22](#)

Performance data — [PAGE 23-25](#)

For more information on these and other PEM® products, visit our PEMNET™ Resource Center at www.pemnet.com.

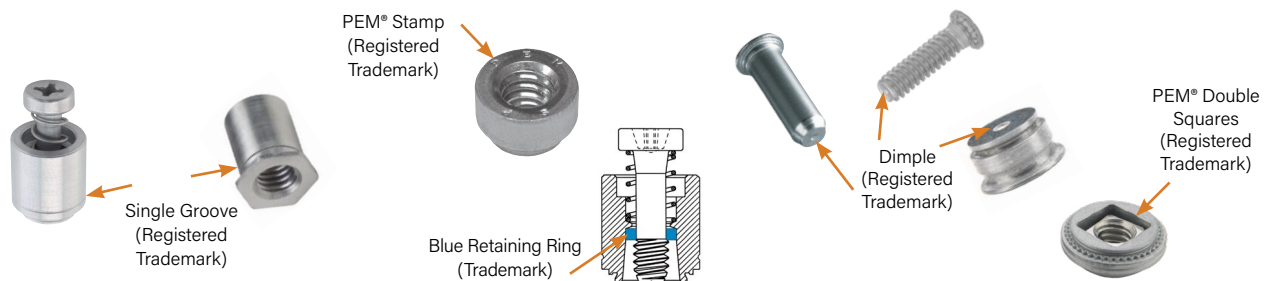

To be sure that you are getting genuine PEM® brand fasteners, look for the unique PEM® product markings and identifiers. On actual parts, location of groove on fastener may be different than shown in photo.

SP™ PEM 300® Self-Clinching Nuts

- After installation, reverse side of sheet remains flush and smooth.
- For use in stainless steel sheets HRB 90 / HB 192 or less.
- Corrosion resistance similar to 300 series stainless steel.



The PEM 300® Identification Marks

Part Number Designation

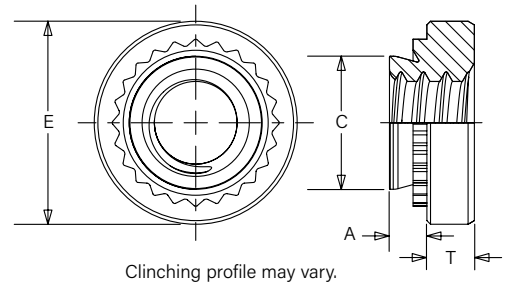
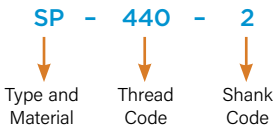

All dimensions are in inches.

Unified	Thread Size	Type	Thread Code	Shank Code	A (Shank) Max.	Rec. Min. Sheet Thickness	Hole Size In Sheet +.003 -.000	C Max.	E ±.010	T ±.010	Min. Dist. Hole C/L to Edge (1)
	.086-56 (#2-56)	SP	256		0	.030	.030	.166	.165	.250	.070
1					.038	.040					
2					.054	.056					
.112-40 (#4-40)	SP	440		0	.030	.030	.166	.165	.250	.070	.19
				1	.038	.040					
				2	.054	.056					
.138-32 (#6-32)	SP	632		0	.030	.030	.1875	.187	.280	.070	.22
				1	.038	.040					
				2	.054	.056					
.164-32 (#8-32)	SP	832		0	.030	.030	.213	.212	.310	.090	.27
				1	.038	.040					
				2	.054	.056					
.190-24 (#10-24)	SP	024		0	.030	.030	.250	.249	.340	.090	.28
				1	.038	.040					
				2	.054	.056					
.190-32 (#10-32)	SP	032		0	.030	.030	.250	.249	.340	.090	.28
				1	.038	.040					
				2	.054	.056					
.250-20 (1/4-20)	SP	0420		1	.054	.056	.344	.343	.440	.170	.34
				2	.087	.090					
.313-18 (5/16-18)	SP	0518		1	.054	.056	.413	.412	.500	.230	.38
				2	.087	.090					
.313-24 (5/16-24)	SP	0524		1	.054	.056	.413	.412	.500	.230	.38
				2	.087	.090					
.375-16 (3/8-16)	SP	0616		1	.087	.090	.500	.499	.560	.270	.44
				2	.120	.125					
.375-24 (3/8-24)	SP	0624		1	.087	.090	.500	.499	.560	.270	.44
				2	.120	.125					

All dimensions are in millimeters.

Metric	Thread Size x Pitch	Type	Thread Code	Shank Code	A (Shank) Max.	Rec. Min. Sheet Thickness	Hole Size In Sheet +0.08	C Max.	E ±0.25	T ±0.25	Min. Dist. Hole C/L to Edge (1)
	M2 x 0.4	SP	M2		1	0.97	1	4.22	4.2	6.35	1.5
2					1.38	1.4					
M2.5 x 0.45	SP	M2.5		0	0.77	0.8	4.22	4.2	6.35	1.5	4.8
				1	0.97	1					
				2	1.38	1.4					
M3 x 0.5	SP	M3		0	0.77	0.8	4.22	4.2	6.35	1.5	4.8
				1	0.97	1					
				2	1.38	1.4					
M4 x 0.7	SP	M4		0	0.77	0.8	5.41	5.38	7.87	2	6.9
				1	0.97	1					
				2	1.38	1.4					
M5 x 0.8	SP	M5		0	0.77	0.8	6.35	6.33	8.64	2	7.1
				1	0.97	1					
				2	1.38	1.4					
M6 x 1	SP	M6		1	1.38	1.4	8.75	8.73	11.18	4.08	8.6
				2	2.21	2.29					
M8 x 1.25	SP	M8		1	1.38	1.4	10.5	10.47	12.7	5.47	9.7
				2	2.21	2.29					
M10 x 1.5	SP	M10		1	2.21	2.29	14	13.97	17.35	7.48	13.5

(1) For more information on proximity to bends and distance to other clinch hardware, see [PEM® Tech Sheet C/L To Edge](#).

The increased hardness of stainless steel panels requires careful consideration when installing self-clinching fasteners. Refer to "Dos and Don'ts" on [page 27](#) for further information.

NOTE: Occasionally, users of our self-clinching fasteners encounter thread binding issues when assembling fasteners made from stainless steel. This problem is typically related to galling. Technical paper, [PEM® REF/THREAD GALLING](#), answers many of the typical questions that we receive surrounding this problem.

SMPP™ Self-Clinching Nuts

- Installs into stainless steel sheets as thin as .025"/0.64mm.
- Corrosion resistance similar to 300 series stainless steel.
- Reduced outer dimensions and thinner sheet capabilities compared to SP nut thread sizes.
- Recommended for use in stainless steel sheets HRB 90 / HB 192 or less.



Part Number Designation

SMPP - 440

Type and Material

Thread Code

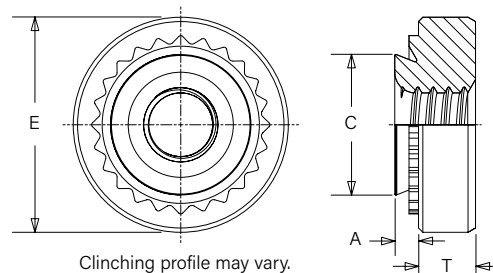

All dimensions are in inches.

Unified	Thread Size	Type	Thread Code	A (Shank) Max.	Min. Sheet Thickness	Hole Size In Sheet +.003 -.000	C Max.	E ±.010	T ±.010	Min. Dist. Hole C/L to Edge (1)
	.086-56 (#2-56)	SMPP	256	.024	.025	.136	.135	.220	.065	.16
	.112-40 (#4-40)	SMPP	440	.024	.025	.166	.165	.220	.065	.20
	.138-32 (#6-32)	SMPP	632	.024	.025	.187	.186	.252	.065	.22

All dimensions are in millimeters.

Metric	Thread Size x Pitch	Type	Thread Code	A (Shank) Max.	Min. Sheet Thickness	Hole Size In Sheet +0.08	C Max.	E ±0.25	T ±0.25	Min. Dist. Hole C/L to Edge (1)
	M2.5 x 0.45	SMPP	M2.5	0.61	0.64	3.8	3.79	5.6	1.4	3.9
	M3 x 0.5	SMPP	M3	0.61	0.64	4.24	4.22	5.6	1.4	5.1
	M3.5 x 0.6	SMPP	M3.5	0.61	0.64	4.75	4.73	6.4	1.4	5.5

(1) For more information on proximity to bends and distance to other clinch hardware, see [PEM® Tech Sheet C/L To Edge](#).

The increased hardness of stainless steel panels requires careful consideration when installing self-clinching fasteners. Refer to "Dos and Don'ts" on [page 27](#) for further information.

NOTE: Occasionally, users of our self-clinching fasteners encounter thread binding issues when assembling fasteners made from stainless steel. This problem is typically related to galling. Technical paper, [PEM® REF/THREAD GALLING](#), answers many of the typical questions that we receive surrounding this problem.

A4™/LA4™ Floating Self-Clinching Fasteners

- Speeds assembly by compensating for mating hole misalignment.
- Permanent installation into stainless steel sheets as thin as .038"/0.97mm and greater.
- Provides high torque-out and pushout resistance in stainless panels.
- LA4 nut thread locking torque performance is equivalent to applicable NASM25027 specifications.⁽¹⁾
- For use in stainless steel sheets HRB 88 / HB 183 or less.

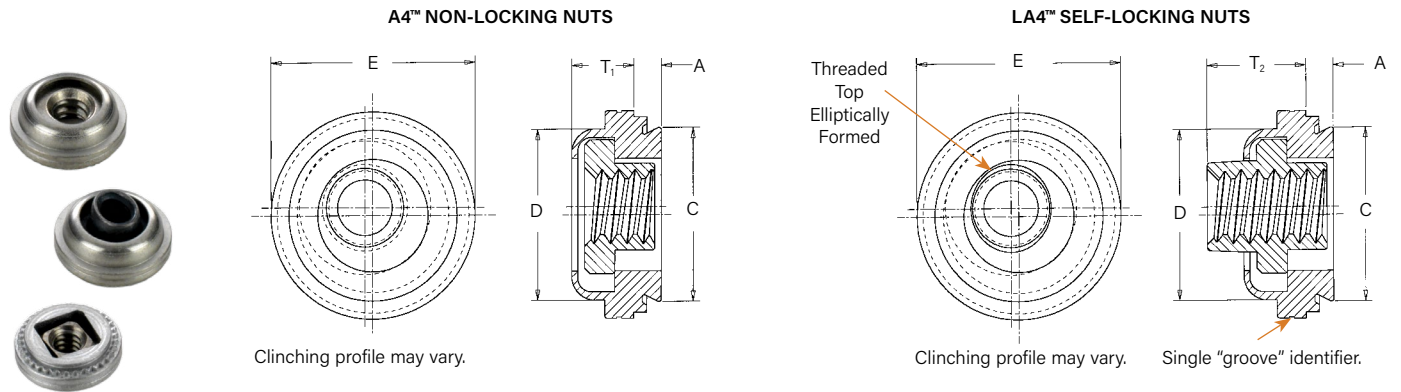

Float - .015"/0.38mm minimum, in all directions from center, .030"/0.76mm total.

Part Number Designation

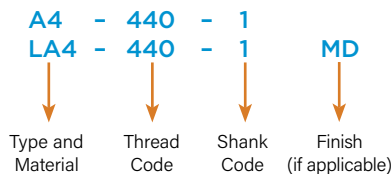

All dimensions are in inches.

	Thread Size	Type		Thread Code	Shank Code	A (Shank) Max.	Min. Sheet Thickness	Hole Size in Sheet +.003 -.000	C Max.	D Max.	E ± .015	T ₁ Max.	T ₂ Max.	Min. Dist. Hole C/L to Edge (1)
		Non-Locking	Self-Locking											
Unified	.112-40 (#4-40)	A4	LA4	440	1	.038	.038	.290	.289	.290	.360	.130	.190	.30
	.138-32 (#6-32)	A4	LA4	632	1	.038	.038	.328	.327	.335	.390	.130	.200	.32
	.164-32 (#8-32)	A4	LA4	832	1	.038	.038	.368	.367	.365	.440	.130	.210	.34
	.190-32 (#10-32)	A4	LA4	032	1	.038	.038	.406	.405	.405	.470	.170	.270	.36

All dimensions are in millimeters.

	Thread Size x Pitch	Type		Thread Code	Shank Code	A (Shank) Max.	Min. Sheet Thickness	Hole Size in Sheet + 0.08	C Max.	D Max.	E ± 0.38	T ₁ Max.	T ₂ Max.	Min. Dist. Hole C/L to Edge (1)
		Non-Locking	Self-Locking											
Metric	M3 x 0.5	A4	LA4	M3	1	0.97	0.97	7.37	7.35	7.37	9.14	3.31	4.83	7.62
	M4 x 0.7	A4	LA4	M4	1	0.97	0.97	9.35	9.33	9.28	11.18	3.31	5.34	8.64
	M5 x 0.8	A4	LA4	M5	1	0.97	0.97	10.31	10.29	10.29	11.94	4.32	6.86	9.14

(1) For more information on proximity to bends and distance to other clinch hardware, see [PEM® Tech Sheet C/L To Edge](#).

The increased hardness of stainless steel panels requires careful consideration when installing self-clinching fasteners. Refer to "Dos and Don'ts" on [page 27](#) for further information.

(1) To meet national aerospace standards and to obtain testing documentation, product must be ordered to US NASM45938/11 specifications. Check our web site for a complete Military Specification and National Aerospace Standards Reference Guide (Bulletin NASM). Screws for use with PEM self-clinching locking fasteners should be Class 3A/4h fit or no smaller than Class 2A/6g.

F4™ PEMSERT® Self-Clinching Flush Fasteners

- Can be installed into sheets as thin as .060"/1.53mm.
- Ideal for flush applications where a stainless steel sheet requires load-bearing threads.
- Can be installed before bending and forming to provide strong threads while still remaining flat with no protrusions on either surface.
- For use in stainless steel sheets HRB 88 / HB 183 or less.



Part Number Designation

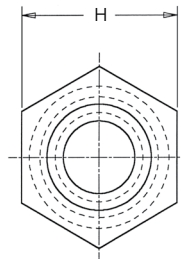
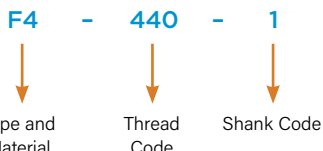

Profile for -1 shank code.

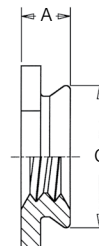

Profile for -2, -3, -4, & -5 shank codes.

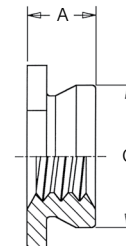

Clinching profile may vary.

All dimensions are in inches.

Unified	Thread Size	Type	Thread Code	Shank Code	A (Shank) Max.	Sheet Thickness	Hole Size In Sheet +.003 -.000	C Max.	H Nom.	Min. Dist. Hole C/L to Edge (1)
	.086-56 (#2-56)	F4	256		1	.060	.060-.090	.172	.171	.188
2					.090	.091 Min.				
.112-40 (#4-40)	F4	440		1	.060	.060-.090	.172	.171	.188	.23
				2	.090	.091 Min.				
.138-32 (#6-32)	F4	632		1	.060	.060-.090	.213	.212	.250	.27
				2	.090	.091 Min.				
.164-32 (#8-32)	F4	832		1	.060	.060-.090	.290	.289	.312	.28
				2	.090	.091 Min.				
.190-32 (#10-32)	F4	032		1	.060	.060-.090	.312	.311	.343	.31
				2	.090	.091 Min.				
.250-20 (1/4-20)	F4	0420		3	.120	.125-.155	.344	.343	.375	.34
				4	.151	.156-.186				
				5	.182	.187 Min.				

All dimensions are in millimeters.

Metric	Thread Size x Pitch	Type	Thread Code	Shank Code	A (Shank) Max.	Sheet Thickness	Hole Size In Sheet +0.08	C Max.	H Nom.	Min. Dist. Hole C/L to Edge (1)
	M2 x 0.4	F4	M2		1	1.53	1.53-2.3	4.37	4.35	4.8
2					2.3	2.32 Min.				
M2.5 x 0.45	F4	M2.5		1	1.53	1.53-2.3	4.37	4.35	4.8	6
				2	2.3	2.32 Min.				
M3 x 0.5	F4	M3		1	1.53	1.53-2.3	4.37	4.35	4.8	6
				2	2.3	2.32 Min.				
M4 x 0.7	F4	M4		1	1.53	1.53-2.3	7.37	7.35	7.9	7.2
				2	2.3	2.32 Min.				
M5 x 0.8	F4	M5		1	1.53	1.53-2.3	7.92	7.9	8.7	8
				2	2.3	2.32 Min.				
M6 x 1	F4	M6		3	3.05	3.18-3.94	8.74	8.72	9.5	8.8
				4	3.84	3.96-4.72				
				5	4.63	4.75 Min.				

(1) For more information on proximity to bends and distance to other clinch hardware, see [PEM® Tech Sheet C/L To Edge](#).

The increased hardness of stainless steel panels requires careful consideration when installing self-clinching fasteners. Refer to "Dos and Don'ts" on [page 27](#) for further information.

SO4™ Thru-Hole Threaded Standoffs

- Ideal for stacking or spacing.
- Installed with head flush with one surface of the mounting sheet.
- For use in stainless steel sheets HRB 88 / HB 183 or less.

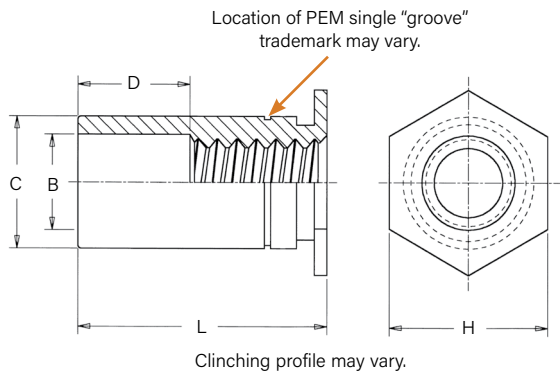

General Dimensional Data

All dimensions are in inches.

Unified	Thread Code	Min. Sheet Thickness	Hole Size In Sheet +.003 -.000	B Counter-Bore Dia. ±.005	C +.000 -.005	H Nom.	Min. Dist. Hole C/L to Edge (1)	D ±.010
	440	.040	.166	.125	.165	.187	.23	Varies according to length. See length charts below.
	6440	.040	.213	.125	.212	.250	.27	
	632	.040	.213	.156	.212	.250	.27	
	8632	.050	.281	.156	.280	.312	.31	
	832	.050	.281	.188	.280	.312	.31	
032	.050	.281	.203	.280	.312	.31		

All dimensions are in millimeters.

Metric	Thread Code	Min. Sheet Thickness	Hole Size In Sheet +0.08	B Counter-Bore Dia. ±0.13	C -0.13	H Nom.	Min. Dist. Hole C/L to Edge (1)	D ±0.25
	M3	1	4.22	3.25	4.2	4.8	6	Varies according to length. See length charts below.
	3.5M3	1	5.41	3.25	5.39	6.4	6.8	
	M3.5	1	5.41	3.9	5.39	6.4	6.8	
	M4	1.27	7.14	4.8	7.12	7.9	8	
	M5	1.27	7.14	5.35	7.12	7.9	8	

(1) For more information on proximity to bends and distance to other clinch hardware, see [PEM® Tech Sheet C/L To Edge](#).

Part Number Designation



SO4 - 440 - 8

SO4 → Type and Material
440 → Thread Code
8 → Length Code

Thread Size And Length Selection Data

All dimensions are in inches.

Unified	Thread Size	Type	Thread Code	Length "L" +.002 -.005 (Length Code in 32nds of an inch)																
				.125	.187	.250	.312	.375	.437	.500	.562	.625	.687	.750	.812	.875	.937	1.00	1.062	
	.112-40 (#4-40)	S04	440	4	6	8	10	12	14	16	18	20	22	24	—	—	—	—		
			6440 ⁽²⁾	4	6	8	10	12	14	16	18	20	22	24	26	28	30	32	34	
	.138-32 (#6-32)	S04	632	4	6	8	10	12	14	16	18	20	22	24	26	28	30	32	34	
			8632 ⁽²⁾	4	6	8	10	12	14	16	18	20	22	24	26	28	30	32	34	
.164-32 (#8-32)	S04	832	4	6	8	10	12	14	16	18	20	22	24	26	28	30	32	34		
.190-32 (#10-32)	S04	032	4	6	8	10	12	14	16	18	20	22	24	26	28	30	32	34		
D Dimension ±.010			None				.187				.312				.437					

All dimensions are in millimeters.

Metric	Thread Size x Pitch	Type	Thread Code	Length "L" +0.05 -0.13 (Length Code in millimeters)													
				3	4	6	8	10	12	14	16	18	—	—	—		
	M3 x 0.5	S04	M3	3	4	6	8	10	12	14	16	18	—	—	—		
			3.5M3 ⁽²⁾	3	4	6	8	10	12	14	16	18	20	22	25		
	M3.5 x 0.6	S04	M3.5	3	4	6	8	10	12	14	16	18	20	22	25		
	M4 x 0.7	S04	M4	3	4	6	8	10	12	14	16	18	20	22	25		
M5 x 0.8	S04	M5	3	4	6	8	10	12	14	16	18	20	22	25			
D Dimension ±0.25			None				4				8				11		

(2) Standoffs with thread codes 6440, 8632, and 3.5M3 offer greater wall thickness for thread sizes 440, 632, and M3 respectively.

The increased hardness of stainless steel panels requires careful consideration when installing self-clinching fasteners. Refer to "Dos and Don'ts" on [page 27](#) for further information.

BSO4™ Blind Threaded Standoffs

- Ideal for stacking or spacing.
- Installed with closed end head flush with one surface of the mounting sheet.
- For use in stainless steel sheets HRB 88 / HB 183 or less.

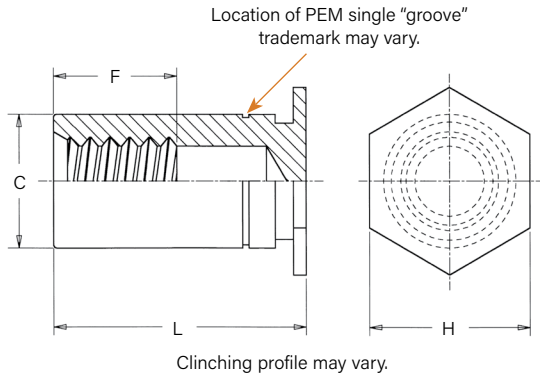

General Dimensional Data

All dimensions are in inches.

Unified	Thread Code	Min. Sheet Thickness	Hole Size In Sheet +.003 -.000	C +.000 -.005	H Nom.	Min. Dist. Hole C/L to Edge (1)	F Min.
	440	.040	.166	.165	.187	.23	Varies according to length. See length charts below.
	6440	.040	.213	.212	.250	.27	
	632	.040	.213	.212	.250	.27	
	8632	.050	.281	.280	.312	.31	
	832	.050	.281	.280	.312	.31	
032	.050	.281	.280	.312	.31		

All dimensions are in millimeters.

Metric	Thread Code	Min. Sheet Thickness	Hole Size In Sheet +0.08	C -0.13	H Nom.	Min. Dist. Hole C/L to Edge (1)	F Min.
	M3	1	4.22	4.2	4.8	6	Varies according to length. See length charts below.
	3.5M3	1	5.41	5.39	6.4	6.8	
	M3.5	1	5.41	5.39	6.4	6.8	
	M4	1.27	7.14	7.12	7.9	8	
	M5	1.27	7.14	7.12	7.9	8	

(1) For more information on proximity to bends and distance to other clinch hardware, see [PEM® Tech Sheet C/L To Edge](#).

Part Number Designation

BSO4 - 440 - 8



Type and Material Thread Code Length Code

Thread Size And Length Selection Data

All dimensions are in inches.

Unified	Thread Size	Type	Thread Code	Length "L" +.002 -.005 (Length Code in 32nds of an inch)												
				.312	.375	.437	.500	.562	.625	.687	.750	.812	.875	.937	1.00	1.062
	.112-40 (#4-40)	BSO4	440	10	12	14	16	18	20	22	24	26	28	30	32	34
			6440 ⁽²⁾													
	.138-32 (#6-32)	BSO4	632	10	12	14	16	18	20	22	24	26	28	30	32	34
			8632 ⁽²⁾													
.164-32 (#8-32)	BSO4	832	10	12	14	16	18	20	22	24	26	28	30	32	34	
.190-32 (#10-32)	BSO4	032	10	12	14	16	18	20	22	24	26	28	30	32	34	
F Dimension Min.				.156	.187	.250			.375							

All dimensions are in millimeters.

Metric	Thread Size x Pitch	Type	Thread Code	Length "L" +0.05 -0.13 (Length Code in millimeters)										
				6	8	10	12	14	16	18	20	22	25	
	M3 x 0.5	BSO4	M3	6	8	10	12	14	16	18	20	22	25	
			3.5M3 ⁽²⁾											
	M3.5 x 0.6	BSO4	M3.5	6	8	10	12	14	16	18	20	22	25	
	M4 x 0.7	BSO4	M4	6	8	10	12	14	16	18	20	22	25	
M5 x 0.8	BSO4	M5	6	8	10	12	14	16	18	20	22	25		
F Dimension Min.			3.2	4		5	6.5			9.5				

(2) Standoffs with thread codes 6440, 8632, and 3.5M3 offer greater wall thickness for thread sizes 440, 632, and M3 respectively.

The increased hardness of stainless steel panels requires careful consideration when installing self-clinching fasteners. Refer to "Dos and Don'ts" on [page 27](#) for further information.

TSO4™ Standoffs For Installation Into Ultra-Thin Stainless Steel Sheets

- For installation into ultra-thin stainless steel sheets as thin as .025"/0.63mm.
- Threads on barrel end eliminate the need for long screws.
- For use in stainless steel sheets HRB 88 / HB 183 or less.

General Dimensional Data

All dimensions are in inches.

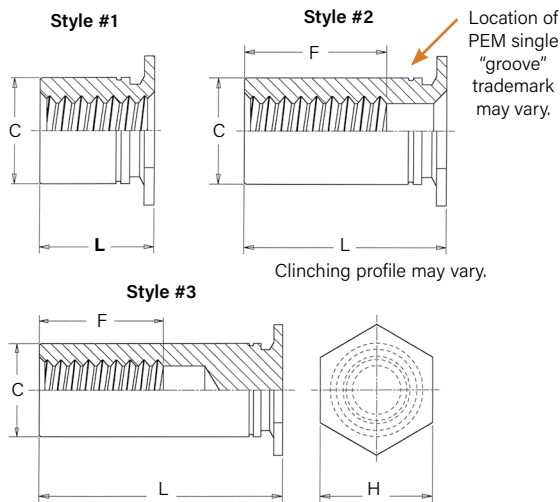

Unified	Thread Code	Min. Sheet Thickness	Hole Size In Sheet +.003 -.000	C +.000 -.005	F Min. Thread Depth	H Nom.	Min. Dist. Hole C/L to Edge (5)
	256	.025	.166	.165	.200	.187	.23
	6256	.025	.213	.212		.250	.27
	440	.025	.166	.165	.220	.187	.23
	6440	.025	.213	.212		.250	.27
632	.025	.213	.212	.270		.250	.27

All dimensions are in millimeters.

Metric	Thread Code	Min. Sheet Thickness	Hole Size In Sheet +0.08	C -0.13	F Min. Thread Depth	H Nom.	Min. Dist. Hole C/L to Edge (5)
	M25	0.63	4.22	4.2	5.2	4.8	5.8
	6M25	0.63	5.41	5.39		6.4	7.1
	M3	0.63	4.22	4.2	6.2	4.8	5.8
	6M3	0.63	5.41	5.39		6.4	7.1
M35	0.63	5.41	5.39	7		6.4	7.1

(5) For more information on proximity to bends and distance to other clinch hardware, see [PEM® Tech Sheet C/L To Edge](#).

Thread Size And Length Selection Data

All dimensions are in inches.

Unified	Thread Size	Type	Thread Code	Length "L" ±.003												
				For other lengths / thread depth data see chart at bottom of page.												
				.090	.125	.187	.250	.312	.375	.437	.500	.562	.625	.687	.750	
				Length Code (Length "L" without decimal point)												
.086-56 (#2-56)	TSO4	256	6256 ⁽⁴⁾	090 ⁽¹⁾	125 ⁽¹⁾	187 ⁽¹⁾	250 ⁽¹⁾	312 ⁽²⁾	375 ⁽²⁾	437 ⁽³⁾	500 ⁽³⁾	562 ⁽³⁾	625 ⁽³⁾	687 ⁽³⁾	750 ⁽³⁾	
				440	6440 ⁽⁴⁾	090 ⁽¹⁾	125 ⁽¹⁾	187 ⁽¹⁾	250 ⁽¹⁾	312 ⁽²⁾	375 ⁽²⁾	437 ⁽²⁾	500 ⁽³⁾	562 ⁽³⁾	625 ⁽³⁾	687 ⁽³⁾
.138-32 (#6-32)	TSO4	632	-	125 ⁽¹⁾	187 ⁽¹⁾	250 ⁽¹⁾	312 ⁽¹⁾	375 ⁽²⁾	437 ⁽²⁾	500 ⁽²⁾	562 ⁽³⁾	625 ⁽³⁾	687 ⁽³⁾	750 ⁽³⁾		

All dimensions are in millimeters.

Metric	Thread Size x Pitch	Type	Thread Code	Length "L" ±0.08												
				For other lengths / thread depth data see chart at bottom of page.												
				2.00	3.00	4.00	6.00	8.00	10.00	12.00	14.00	16.00	18.00	19.00		
				Length Code (Length "L" without decimal point)												
M2.5 x 0.45	TSO4	M25	6M25 ⁽⁴⁾	200 ⁽¹⁾	300 ⁽¹⁾	400 ⁽¹⁾	600 ⁽¹⁾	800 ⁽²⁾	1000 ⁽³⁾	1200 ⁽³⁾	1400 ⁽³⁾	1600 ⁽³⁾	1800 ⁽³⁾	1900 ⁽³⁾		
				M3	6M3 ⁽⁴⁾	200 ⁽¹⁾	300 ⁽¹⁾	400 ⁽¹⁾	600 ⁽¹⁾	800 ⁽²⁾	1000 ⁽²⁾	1200 ⁽³⁾	1400 ⁽³⁾	1600 ⁽³⁾	1800 ⁽³⁾	1900 ⁽³⁾
M3.5 x 0.6	TSO4	M35	-	300 ⁽¹⁾	400 ⁽¹⁾	600 ⁽¹⁾	800 ⁽¹⁾	1000 ⁽²⁾	1200 ⁽²⁾	1400 ⁽³⁾	1600 ⁽³⁾	1800 ⁽³⁾	1900 ⁽³⁾			

- (1) Style #1. Thru-threaded.
- (2) Style #2. Screw might not pass through unthreaded end. Tapped to minimum full thread depth shown. Incomplete threads on tap may allow screw to pass through.
- (3) Style #3. Blind.
- (4) Standoffs with thread codes 6256, 6440, 6M25 and 6M3 offer oversized body for increased bearing surface, wall thickness and performance. Please contact your local PEM® distributor for availability, minimum quantity, and pricing information.

Length/Style Data

All dimensions are in inches.
(Length can be specified in .001" increments.)

Unified	Thread Code	Length "L" (Style #1)	Length "L" (Style #2)	Length "L" (Style #3)
	256	.090 - .250	.251 - .375	.376 - .750
	6256			
	440	.090 - .280	.281 - .450	.451 - .750
	6440			
632	.120 - .350	.351 - .540	.541 - .750	

All dimensions are in millimeters.
(Length can be specified in .02 mm increments.)

Metric	Thread Code	Length "L" (Style #1)	Length "L" (Style #2)	Length "L" (Style #3)
	M25	2.00 - 6.30	6.32 - 9.50	9.52 - 19.00
	6M25			
	M3	2.00 - 7.50	7.52 - 11.00	11.02 - 19.00
	6M3			
M35	3.00 - 8.80	8.82 - 12.80	12.82 - 19.00	

Part Number Designation



The increased hardness of stainless steel panels requires careful consideration when installing self-clinching fasteners. Refer to "Dos and Don'ts" on [page 27](#) for further information.

FH4™/FHP™ Flush-Head Studs

- Permanent installation into stainless steel sheets as thin as .040"/1mm.
- FHP studs offers highest corrosion resistance and ideal for medical, food service, and marine applications.
- For use in stainless steel sheets HRB 92 / HB 202 or less.



Part Number Designation

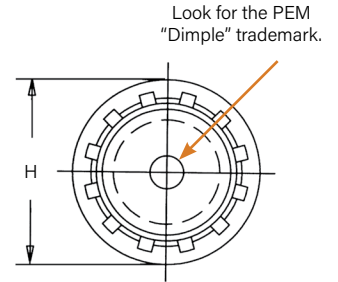
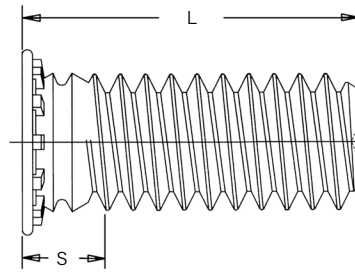
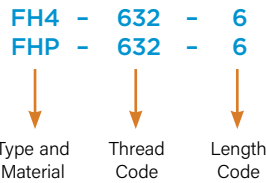

unthreaded length

Clinching profile may vary.

All dimensions are in inches.

Unified	Thread Size	Type		Thread Code	Length Code "L" ±.015 (Length code in 16ths of an inch)										Sheet Thickness (1)	Hole Size in Sheet +.003 -0.000	Max. Hole in Attach. Parts	H ±.015	S Max. (2)	Min. Dist. Hole C/L to Edge (3)
					.250	.312	.375	.500	.625	.750	.875	1.00	1.25	1.50						
	FH4	FHP	440	4	5	6	8	10	12	14	16	—	—	.040-.095	.111	.131	.176	.085	.219	
	.138-32 (#6-32)	FH4	FHP	632	4	5	6	8	10	12	14	16	20	24	.040-.095	.137	.157	.206	.090	.250
	.164-32 (#8-32)	FH4	FHP	832	4	5	6	8	10	12	14	16	20	24	.040-.095	.163	.183	.237	.090	.281
	.190-32 (#10-32)	FH4	FHP	032	—	5	6	8	10	12	14	16	20	24	.040-.095	.189	.209	.256	.100	.281
	.250-20 (1/4-20)	FH4	—	0420	—	—	6	8	10	12	14	16	20	24	.062-.117	.249	.269	.337	.135	.312

All dimensions are in millimeters.

Metric	Thread Size x Pitch	Type		Thread Code	Length Code "L" ±0.4 (Length Code in millimeters)										Sheet Thickness (1)	Hole Size in Sheet +0.08	Max. Hole in Attach. parts	H ±0.4	S Max. (2)	Min. Dist. Hole C/L to Edge (3)
					6	8	10	12	15	18	20	25	—	—						
	M3 x 0.5	FH4	FHP	M3	6	8	10	12	15	18	20	25	—	—	1 - 2.4	3	3.3	4.6	2.1	5.6
	M4 x 0.7	FH4	FHP	M4	6	8	10	12	15	18	20	25	30	35	1 - 2.4	4	4.7	5.9	2.4	7.2
	M5 x 0.8	FH4	FHP	M5	—	8	10	12	15	18	20	25	30	35	1 - 2.4	5	5.3	6.5	2.7	7.2
	M6 x 1	FH4	—	M6	—	—	10	12	15	18	20	25	30	35	1.6 - 3	6	6.8	8.2	3	7.9

- (1) Performance may be reduced for studs installed into thicker sheets.
- (2) Threads are gaugeable to within 2 pitches of the "S" Max. dimension. A class 3B/5H maximum material commercial nut shall pass up to the "S" Max. dimension.
- (3) For more information on proximity to bends and distance to other clinch hardware, see [PEM® Tech Sheet C/L To Edge](#).

The increased hardness of stainless steel panels requires careful consideration when installing self-clinching fasteners. Refer to "Dos and Don'ts" on [page 27](#) for further information.

SGPC™ Swaging Collar Studs

- Installs into sheets as thin as .024"/0.6mm.
- Can be used to attach dissimilar materials.
- Can accommodate multiple panels as long as the total thickness does not exceed the maximum sheet thickness.⁽¹⁾
- Can be installed into most panel materials, including stainless steel.
- Allows for close centerline-to-edge distance.

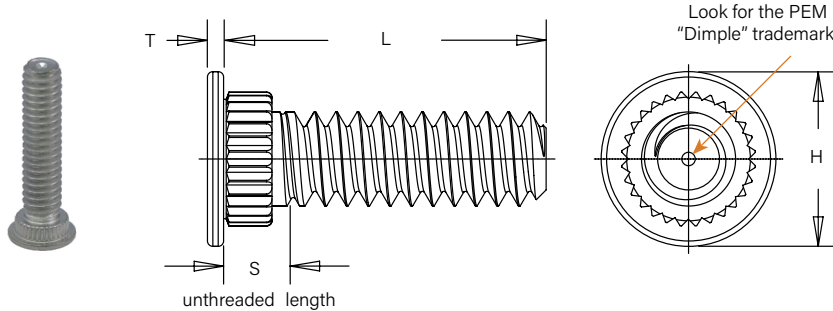

Part Number Designation

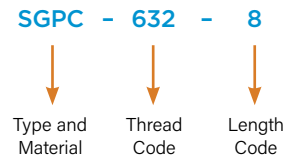

All dimensions are in inches.

Unified	Thread Size	Type	Thread Code	Length Code "L" ±.015 (Length Code in 16ths of an inch)								Sheet Thickness (2)	Hole Size in Sheet +.003 -.000	Hole Dia. of Attached Panel +.005 -.000	H ±.010	S Max. (3)	T ±.004	Min. Dist. Hole C/L to Edge (4)	
		Fastener Material		.312	.375	.500	.625	.750	.875	1.00	1.25								1.50
		Stainless Steel																	
.086-56 (#2-56)	SGPC	256	5	6	8	10	12	—	—	—	—	.024 - .047	.145	.182	.189	.093	.020	.130	
.112-40 (#4-40)	SGPC	440	5	6	8	10	12	14	16	20	—	.024 - .047	.171	.205	.228	.101	.024	.160	
.138-32 (#6-32)	SGPC	632	5	6	8	10	12	14	16	20	24	.024 - .047	.196	.229	.256	.109	.024	.180	
.164-32 (#8-32)	SGPC	832	5	6	8	10	12	14	16	20	24	.024 - .047	.223	.259	.279	.109	.024	.200	
.190-32 (#10-32)	SGPC	032	5	6	8	10	12	14	16	20	24	.024 - .047	.249	.280	.307	.109	.024	.210	
.250-20 (1/4-20)	SGPC	0420	—	6	8	10	12	14	16	20	24	.024 - .047	.309	.343	.366	.131	.028	.250	

All dimensions are in millimeters.

Metric	Thread Size x Pitch	Type	Thread Code	Length Code "L" ±0.4 (Length Code in millimeters)								Sheet Thickness (2)	Hole Size in Sheet +0.08	Hole Dia. of Attached Panel +0.13	H ±0.25	S Max. (3)	T ±0.1	Min. Dist. Hole C/L to Edge (4)	
		Fastener Material		8	10	12	15	18	—	—	—								—
		Stainless Steel																	
M2.5 x 0.45	SGPC	M2.5	8	10	12	15	18	—	—	—	—	0.6 - 1.2	4	4.95	5	2.4	0.5	3.9	
M3 x 0.5	SGPC	M3	8	10	12	15	18	20	25	—	—	0.6 - 1.2	4.5	5.45	6	2.5	0.6	4.3	
M4 x 0.7	SGPC	M4	8	10	12	15	18	20	25	30	—	0.6 - 1.2	5.5	6.3	7	2.7	0.6	4.9	
M5 x 0.8	SGPC	M5	8	10	12	15	18	20	25	30	35	0.6 - 1.2	6.5	7.45	8	2.8	0.6	5.5	
M6 x 1	SGPC	M6	—	10	12	15	18	20	25	30	35	0.6 - 1.2	7.5	8.3	9	3	0.7	6.2	

(1) When using the fastener to attach more than one sheet or panel, the stud may seem slightly loose after installation. This is a normal condition in some applications and will not affect the stud's performance.

(2) See installation data for tooling requirements. Contact Technical Support (techsupport@pemnet.com) for other thicknesses.

(3) Threads are gaugeable to within 2 pitches on the "S" Max. dimension. A class 3B/5H maximum material commercial nut shall pass up to the "S" Max. dimension.

(4) For more information on proximity to bends and distance to other clinch hardware, see [PEM® Tech Sheet C/L To Edge](#).

TP4™ Flush-Head Pins

- Permanent installation into stainless steel sheets as thin as .040"/1mm.
- Satisfies a wide range of positioning, pivot, and alignment applications.
- Chamfered end makes mating hole location easy.
- For use in stainless steel sheets HRB 92 / HB 202 or less.

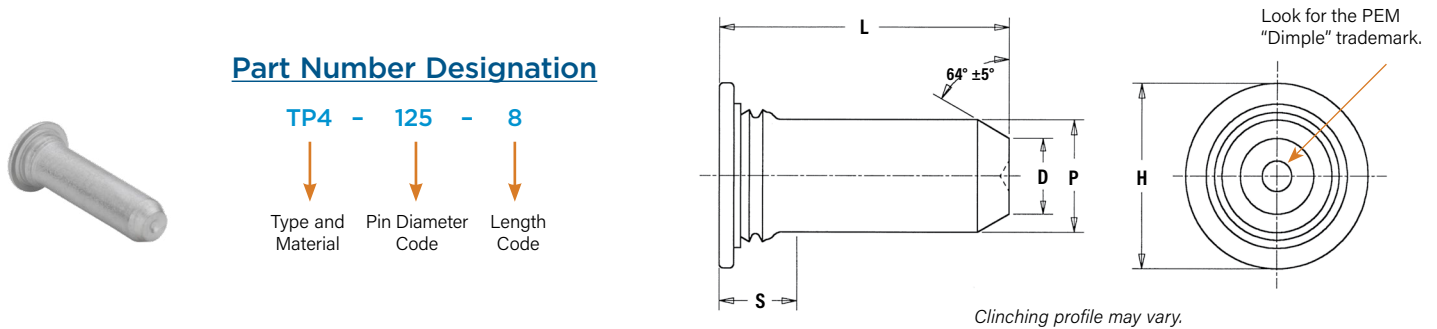

All dimensions are in inches.

Unified	Pin Diameter P ±.002	Type	Pin Diameter Code	Length Code "L" ± .015 (Length Code in 16ths of an inch)					Min. Sheet Thickness	Hole Size in Sheet +.003 -.000	D ±.006	H ±.015	S Max. (1)	Min. Dist. Hole C/L to Edge (2)
				.375	.500	.625	.750	1.00						
	.125	TP4	125	6	8	10	12	—	.040	.144	.090	.205	.090	.250
	.187	TP4	187	6	8	10	12	16	.040	.205	.132	.270	.090	.280
	.250	TP4	250	—	8	10	12	16	.040	.272	.177	.335	.090	.310

All dimensions are in millimeters.

Metric	Pin Diameter P ±0.05	Type	Pin Diameter Code	Length Code "L" ± 0.4 (Length Code in millimeters)					Min. Sheet Thickness	Hole Size in Sheet +0.08	D ±0.15	H ±0.4	S Max. (1)	Min. Dist. Hole C/L to Edge (2)
				8	10	12	16	—						
	3	TP4	3MM	8	10	12	16	—	1	3.5	2.05	5.2	2.29	6.4
	4	TP4	4MM	8	10	12	16	—	1	4.5	2.82	6.12	2.29	7.1
	5	TP4	5MM	—	10	12	16	20	1	5.5	3.53	7.19	2.29	7.6
	6	TP4	6MM	—	—	12	16	20	1	6.5	4.24	8.13	2.29	7.9

- (1) Pin diameter may exceed max. in this region.
 (2) For more information on proximity to bends and distance to other clinch hardware, see [PEM® Tech Sheet C/L To Edge](#).

The increased hardness of stainless steel panels requires careful consideration when installing self-clinching fasteners. Refer to "Dos and Don'ts" on [page 27](#) for further information.

PFC4™ Captive Panel Screws

- Tool only access meets UL 1950 “service area access” requirements and provides fixed screw solutions for the EC Machinery Directive.
- Assorted screw lengths for most applications.
- For use in stainless steel sheets HRB 88 / HB 183 or less.

Part Number Designation

PFC4- 832 - 50

↓ ↓ ↓

Type and Thread Screw
Material Code Length
Code Code

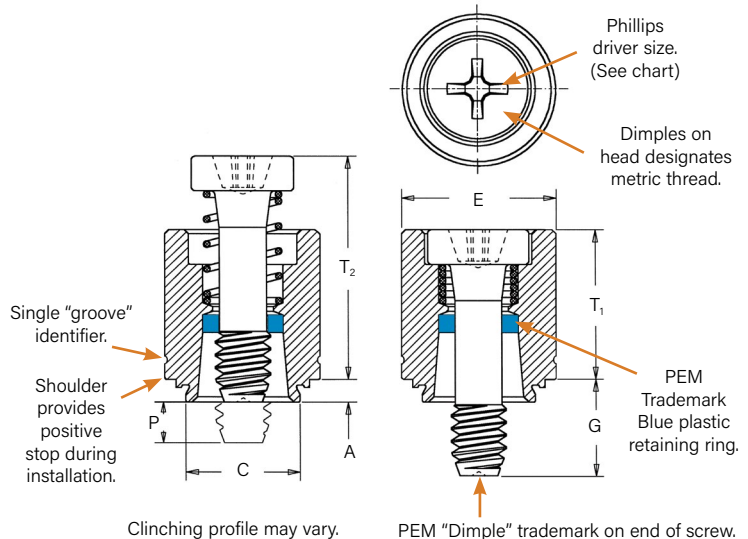

All dimensions are in inches.

Unified	Thread Size	Type	Thread Code	Screw Length Code	A (Shank) Max.	Min. Sheet Thickness	Hole Size In Sheet +.003 -.000	C Max.	E ± .010	G ± .016	P ±.025	T ₁ Max.	T ₂ Nom.	Driver Size	Min. Dist. Hole C/L to Edge (1)
	.112-40 (#4-40)	PFC4	440	40	40	.060	.060	.265	.264	.344	.250	.000	.370	.540	#1
62					.375						.125				
.138-32 (#6-32)	PFC4	632	40	40	.060	.060	.281	.280	.375	.250	.000	.380	.540	#2	.28
				62						.375	.125				
				84						.500	.250				
.164-32 (#8-32)	PFC4	832	50	50	.060	.060	.312	.311	.406	.312	.000	.480	.705	#2	.31
				72						.437	.125				
				94						.562	.250				
.190-32 (#10-32)	PFC4	032	50	50	.060	.060	.344	.343	.437	.312	.000	.490	.705	#2	.34
				72						.437	.125				
				94						.562	.250				

All dimensions are in millimeters.

Metric	Thread Size x Pitch	Type	Thread Code	Screw Length Code	A (Shank) Max.	Min. Sheet Thickness	Hole Size In Sheet + 0.08	C Max.	E ± 0.25	G ± 0.4	P ±0.64	T ₁ Max.	T ₂ Nom.	Driver Size	Min. Dist. Hole C/L to Edge (1)
	M3 x 0.5	PFC4	M3	M3	40	1.53	1.53	6.73	6.71	8.74	6.4	0	9.4	13.72	#1
62					9.5						3.2				
M4 x 0.7	PFC4	M4	M4	50	1.53	1.53	7.92	7.9	10.31	7.9	0	12.19	17.91	#2	7.87
				72						11.1	3.2				
				94						14.3	6.4				
M5 x 0.8	PFC4	M5	M5	50	1.53	1.53	8.74	8.72	11.1	7.9	0	12.45	17.91	#2	8.63
				72						11.1	3.2				
				94						14.3	6.4				

(1) For more information on proximity to bends and distance to other clinch hardware, see [PEM® Tech Sheet C/L To Edge](#).

The increased hardness of stainless steel panels requires careful consideration when installing self-clinching fasteners. Refer to “Dos and Don’ts” on [page 27](#) for further information.

SFP™ Spotfast® Fasteners

- Allows permanent joining of two metal sections.
- Offers high corrosion resistance.
- Can be used as single flush-mounted pivot point.
- Installs smooth with top sheet and flush or sub-flush with the bottom sheet.
- For use in sheets of HRB 88 / HB 183 or less.

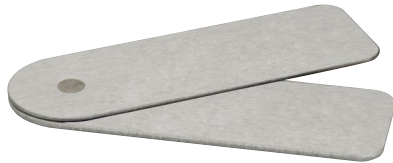

SpotFast® fastener used as a single flush-mounted pivot point. Top panel rotates about the SpotFast fastener.

Part Number Designation

SFP - 3 - 1.0

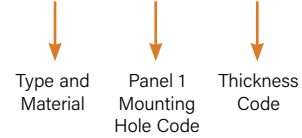

Patented

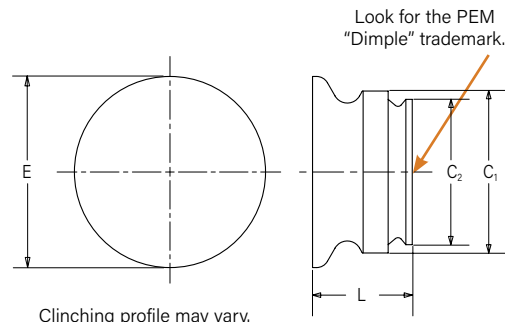
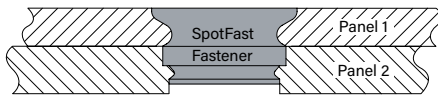

Clinching profile may vary.

Type and Size	Thickness Code	Panel 1				Panel 2				C ₁ Max.		C ₂ Max.		E Max.		L Max.		Min. Dist. Hole C/L to Edge (2)	
		Thickness ±0.08 mm / ±.003"		Mounting Hole +0.08 mm / +.003" -.000"		Thickness Min. (1)		Mounting Hole +0.08 mm / +.003" -.000"											
		mm	in.	mm	in.	mm	in.	mm	in.	mm	in.	mm	in.	mm	in.	mm	in.		
SFP-3	1.0	1	.039	3	.118	1	.039	2.5	.098	2.98	.117	2.48	.097	3.76	.148	1.9	.075	2.54	.1
SFP-3	1.2	1.2	.047	3	.118	1.2	.047	2.5	.098	2.98	.117	2.48	.097	3.76	.148	2.31	.091	2.54	.1
SFP-3	1.6	1.6	.063	3	.118	1.6	.063	2.5	.098	2.98	.117	2.48	.097	3.76	.148	3.12	.123	2.54	.1
SFP-5	1.0	1	.039	5	.197	1	.039	4.5	.177	4.98	.196	4.47	.176	5.56	.219	1.9	.075	3.6	.14
SFP-5	1.2	1.2	.047	5	.197	1.2	.047	4.5	.177	4.98	.196	4.47	.176	5.56	.219	2.31	.091	3.6	.14
SFP-5	1.6	1.6	.063	5	.197	1.6	.063	4.5	.177	4.98	.196	4.47	.176	5.56	.219	3.12	.123	3.6	.14

(1) Fastener will provide flush application at minimum sheet thickness.

(2) For more information on proximity to bends and distance to other clinch hardware, see [PEM® Tech Sheet C/L To Edge](#).

The increased hardness of stainless steel panels requires careful consideration when installing self-clinching fasteners. Refer to "Dos and Don'ts" on [page 27](#) for further information.

Material And Finish Specifications

Type	Threads			Fastener Materials				Finish		For Use in Sheet Hardness ⁽¹⁾				Corrosion Resistance	Magnetic
	Internal, ASME B1.1 2B/ ASME B1.13M, 6H	External, ASME B1.1 2A/ ASME B1.13M, 6g	Internal, UNJ Class 3B per ASME B1.15 / MJ Class 4H6H per ASME B1.2M (M6 thread 4H5H)	Precipitation Hardening Grade Stainless Steel	Heat-Treated 400 Series Stainless Steel	300 Series Stainless Steel	Age Hardened A286 Stainless Steel	Passivated and/or Tested per ASTM A380	Black Dry-film Lubricant	HRB 92 / HB 202 or less	HRB 90 / HB 192 or less	HRB 88 / HB 183 or less	Any Sheet Hardness		
SP	▪						▪	▪			▪ (2) (3)		Excellent	No	
SMPP	▪						▪	▪			▪		Excellent	No	
A4	▪				▪ (retainer)	▪ (insert)		▪				▪	Fair	Yes	
LA4			▪		▪ (retainer)	▪ (insert)		▪ (retainer)	▪ (insert)			▪	Fair	Yes	
F4	▪				▪			▪				▪	Fair	Yes	
SO4	▪				▪			▪				▪ (4)	Fair	Yes	
BSO4	▪				▪			▪				▪ (4)	Fair	Yes	
TSO4	▪				▪			▪				▪ (4)	Fair	Yes	
FH4		▪			▪			▪		▪			Fair	Yes	
FHP		▪					▪	▪		▪			Excellent	No	
SGPC		▪					▪	▪				▪	Excellent	No	
TP4	Not threaded				▪			▪		▪			Fair	Yes	
PFC4 (Retainer) (Screw) (Spring)					▪			▪				▪	Fair	Yes	
SFP	Not threaded			▪				▪				▪	Excellent	Yes	
Part number codes for finishes								None	MD						

(1) HRB - Hardness Rockwell "B" Scale. HB - Hardness Brinell.

(2) Panel material should be in the annealed condition.

(3) Fasteners should not be installed adjacent to bends or other highly cold-worked areas.

(4) Also available, standoffs for installation into thinner, high strength, HSLA steel. See Innovation Brief "[Standoffs For Hard Panels](#)" on our website.

A Note About 400 Series Fasteners For Stainless Steel Panels

In order for self-clinching fasteners to work properly, the fastener must be harder than the sheet into which it is being installed. In the case of stainless steel panels, fasteners made from 300 Series Stainless Steel do not meet this hardness criteria. It is for this reason that 400 series fasteners are offered (A4, LA4, F4, SO4, BSO4, TSO4, FH4, TP4, and PFC4 fasteners). However, while these 400 Series fasteners install and perform well in 300 Series stainless sheets they should not be used if the end product:

- Will be exposed to any appreciable corrosive presence.
- Requires non-magnetic fasteners.
- Will be exposed to any temperatures above 300°F (149°C)

If any of the these are issues, please contact techsupport@pemnet.com for other options.

Installation

SP™ Nuts

Unified	Thread Code	HAEGER® Part Number		PEMSERTER® Part Number		Anvil Dimensions (in.)			
		Lower Tool	Upper Tool	Anvil	Punch	A ±.002	P +.000 -.001	R Max.	R1 +.005
	440	H-183-4/M3-L	H-108-0020L	8012821	975200048	.255	.064	.010	.005
632	H-183-6/M3.5-L	H-108-0020L	8012822	975200048	.286	.064	.010	.005	
832	H-183-8/M4-L	H-108-0020L	8012823	975200048	.317	.082	.010	.005	
024/032	H-183-10/M5-L	H-108-0020L	8012824	975200048	.348	.082	.010	.005	
0420	H-183-04/M6-L	H-108-0020L	8012825	8003076	.443	.163	.010	.005	
0518	—	—	8015359	8003076	.505	.230	.010	.005	
0616/0624	—	—	8015863	8003076	.570	.263	.010	.005	

Recommended Counterbore Anvil

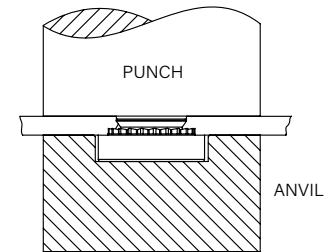
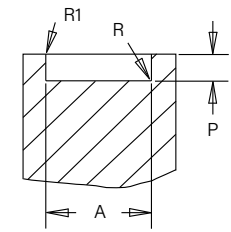

Metric	Thread Code	HAEGER® Part Number		PEMSERTER® Part Number		Anvil Dimensions (mm)			
		Lower Tool	Upper Tool	Anvil	Punch	A ±0.05	P -0.03	R Max.	R1 +0.13
	M2	—	—	8012821	975200048	6.48	1.63	0.25	0.13
M2.5-0	—	—	8019477	975200048	6.48	1.42	0.25	0.13	
M2.5-1,-2	—	—	8012821	975200048	6.48	1.63	0.25	0.13	
M3	H-183-4/M3-L	H-108-0020L	8012821	975200048	6.48	1.63	0.25	0.13	
M3.5	H-183-6/M3.5-L	H-108-0020L	8012822	975200048	7.26	1.63	0.25	0.13	
M4	H-183-8/M4-L	H-108-0020L	8012823	975200048	8.05	2.08	0.25	0.13	
M5	H-183-10/M5-L	H-108-0020L	8012824	975200048	8.84	2.08	0.25	0.13	
M6	H-183-04/M6-L	H-108-0020L	8012825	8003076	11.25	4.14	0.25	0.13	
M8	—	—	8015360	8003076	12.83	5.41	0.25	0.13	
M10	—	—	8015886	8003076	17.58	7.47	0.25	0.13	

SMPP™ Nuts

Unified	Thread Code	HAEGER® Part Number		PEMSERTER® Part Number		Anvil Dimensions (in.)			
		Lower Tool	Upper Tool	Anvil	Punch	A ±.002	P +.000 -.001	R Max.	R1 +.005
	256	10-00278	H-108-0020L	8020023	975200048	.223	.060	.010	.005
440	10-00279	H-108-0020L	8021386	975200048	.233	.060	.010	.005	
632	10-00280	H-108-0020L	8020024	975200048	.255	.060	.010	.005	

Metric	Thread Code	HAEGER® Part Number		PEMSERTER® Part Number		Anvil Dimensions (mm)			
		Lower Tool	Upper Tool	Anvil	Punch	A ±0.05	P -0.03	R Max.	R1 +0.13
	M2.5	10-00292	H-108-0020L	8020025	975200048	5.66	1.27	0.25	0.13
M3	10-00293	H-108-0020L	8021474	975200048	5.9	1.27	0.25	0.13	
M3.5	10-00294	H-108-0020L	8020026	975200048	6.48	1.27	0.25	0.13	

(1) For best results, we recommend using the installation punch and anvil shown. Deviations from recommended installation tooling may result in sheet distortion and reduced performance.

NOTE: Variations in hole preparation, installation tooling, installation force, and sheet material type, thickness, and hardness will affect both performance and tooling life.

A4™/LA4™ Nuts

1. Prepare properly sized mounting hole in sheet. Do not perform any secondary operations such as deburring.
2. Place fastener into the anvil hole and place the mounting hole (punch side) over the shank of the fastener.
3. With installation punch and anvil surfaces parallel, apply sufficient squeezing force until the flange contacts the sheet material.

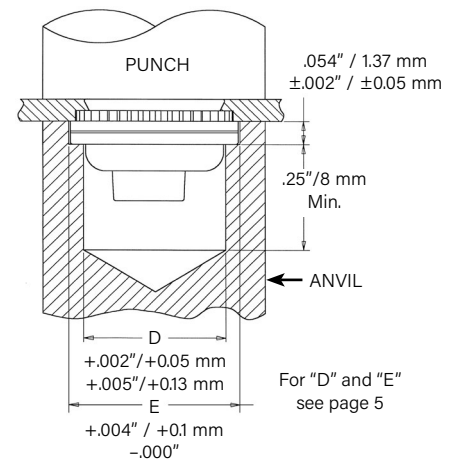

Installation Tooling

Thread Code	HAEGER® Part Number		PEMSERTER® Part Number		Counterbore A		Hole Depth Below Counterbore B	
	Anvil	Punch	Anvil	Punch	±.001"	±0.03mm	±.005"	±0.13mm
	440/M3	H-131-4/M3L	H-108-0020L	8013889	975200048	.054"	1.37mm	.258"
632	H-131-6/M3.5L	H-108-0020L	8013890	975200048	.054"	1.37mm	.258"	6.55mm
832/M4	H-131-8/M4L	H-108-0020L	8013891	975200048	.054"	1.37mm	.258"	6.55mm
032/M5	H-131-10/M5L	H-108-0020L	8013892	975200048	.071"	1.8mm	.241"	6.12mm
0420/M6	H-131-04/M6L	H-108-0020L	8021392	975200048	.092"	2.34mm	.220"	5.59mm

Installation

F4™ Nuts

1. Prepare properly sized round mounting hole in sheet. Do not perform any secondary operations such as deburring.
2. Place shank of fastener into mounting hole (punch side) as show in the drawing.
3. With installation punch and anvil surfaces parallel, apply sufficient squeezing force only to embed hexagonal head flush in sheet. The metal displaced by the head flows evenly and smoothly around the back-tapered shank of the fastener, securely locking it into place with high pullout resistance while at the same time, the embedded hexagonal head provides high torque resistance.

Installation Tooling

Thread Code	HAEGER® Part Number		PEMSERTER® Part Number		Anvil Dimensions			
	Anvil	Punch	Anvil	Punch	A		P	
					+ .002" - .000"	+ 0.05mm	± .005"	± 0.13mm
256/M2/M2.5	H-108-0018L	H-108-0018L	8006193	975200048	.060"	1.52mm	.050"	1.27mm
440/M3	H-108-0018L	H-108-0018L	975200040	975200048	.077"	1.96mm	.050"	1.27mm
632	H-108-0018L	H-108-0018L	975200041	975200048	.092"	2.34mm	.050"	1.27mm
832/M4	H-108-0018L	H-108-0018L	975200042	975200048	.124"	3.15mm	.050"	1.27mm
032/M5	H-108-0018L	H-108-0018L	975200043	975200048	.139"	3.53mm	.050"	1.27mm
0420/M6	H-108-0018L	H-108-0018L	975200044	975200048	.186"	4.72mm	.100"	2.54mm

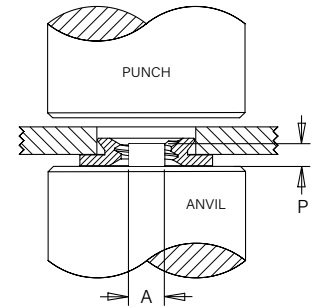

SO4™/BSO4™ Standoffs

1. Prepare properly sized round mounting hole in sheet. Do not perform any secondary operations such as deburring.
2. Insert standoff barrel through mounting hole (punch side) in sheet and into anvil as shown.
3. With installation punch and anvil surfaces parallel, apply only enough squeezing force to embed the standoff's head flush in the sheet.

Installation Tooling

Thread Code	HAEGER® Part No.		PEMSERTER® Part Number	
	Anvil	Punch	Anvil	Punch
440/M2/M2.5/M3	H-109-4/M3L	H-108-0020L	970200487300	975200048
632/6440/3.5M3/M3.5	H-109-6/M3.5L	H-108-0020L	970200012300	975200048
832/8632/032/M4/M5	H-109-8-10/M5L	H-108-0020L	970200013300	975200048
0420/M6	H-109-04/M6L	H-108-0020L	970200393300	975200048

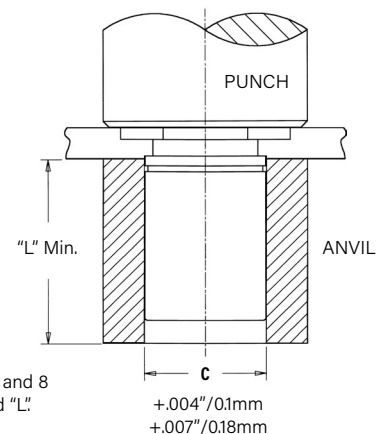

Installation

TSO4™ Standoffs

1. Prepare properly sized mounting hole in sheet. Do not perform any secondary operation such as deburring.
2. Insert standoff through mounting hole (punch side) of sheet and into anvil as shown in drawing.
3. With installation punch and anvil surfaces parallel, apply only enough squeezing force to embed the standoff's head flush in the sheet. Drawing at right shows required installation anvil for sheet thickness of .025" to .032"/0.63 to 0.81mm. A chamfered anvil is not required for sheets over .032"/0.81mm.

Required Installation Anvil For Sheets Below .032"/0.81MM

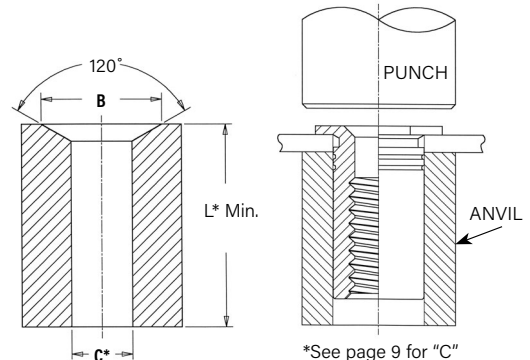

+0.001" to +0.004" / +0.03mm to +0.1mm

Installation Tooling

Unified	Thread Code	HAEGER® Part Numbers				PEMSERTER® Part Numbers			
		Anvil Dimensions (in.) For Sheets Below .032"		Anvil For sheets Over .032"	Punch	Anvil Dimensions (in.) For Sheets Below .032"		Anvil For Sheets Over .032"	Punch
		B	Anvil			B	Anvil		
	256/440	(1)	(1)	H-109-4/M3L	H-108-0020L	.187 - .194	8003291	970200487300	975200048
	6256/6440/632	(1)	(1)	H-109-6/M3.5L	H-108-0020L	.250 - .257	8003292	970200012300	975200048

Metric	Thread Code	HAEGER® Part Numbers				PEMSERTER® Part Numbers			
		Anvil Dimensions (mm) For Sheets Below 0.81 mm		Anvil For sheets Over 0.81 mm	Punch	Anvil Dimensions (mm) For Sheets Below 0.81 mm		Anvil For Sheets Over 0.81 mm	Punch
		B	Anvil			B	Anvil		
	M2.5/M3	(1)	(1)	H-109-4/M3L	H-108-0020L	4.75 - 4.93	8003291	970200487300	975200048
	6M25/6M3/M35	(1)	(1)	H-109-6/M3.5L	H-108-0020L	6.35 - 6.53	8003292	970200012300	975200048

(1) [Click here](#) for a quote on Haeger® custom anvil installation tooling.

Installation

Installation - FH4™/FHP™ Studs For Stainless Steel Sheets

1. Prepare properly sized mounting hole in sheet. Do not perform any secondary operations such as deburring.
2. Insert stud through mounting hole (punch side) of sheet and into anvil hole.
3. With punch and anvil surfaces parallel, apply squeezing force to embed the head of the stud flush in the sheet.

For FH4/FHP studs, a special anvil with a raised ring is required to create a proper installation. The raised ring acts as a second displacer of the stainless sheet material, thereby ensuring that the annular groove is filled. Please see page 10 for recommended sheet thickness range.

The special anvils are available from PEM stock or can be machined from suitable tool steel. A hardness of HRC 55 / HB 547 minimum is required to provide long anvil life. We recommend measuring the "P" dimension every 5000 installations to ensure that the anvil remains within specification.

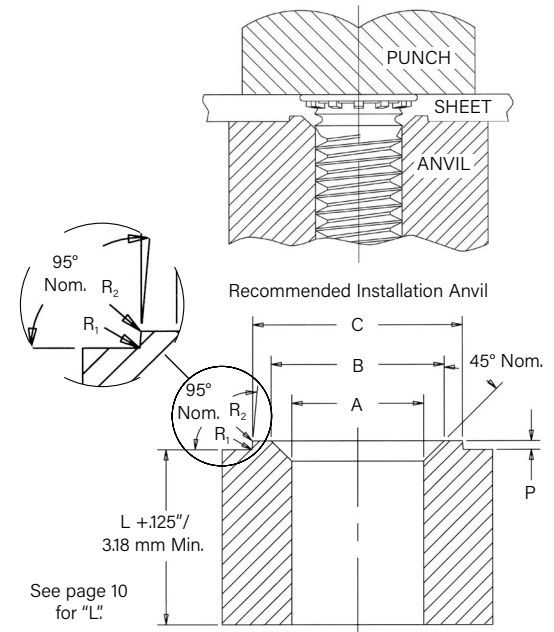

Installation Tooling

Unified	Thread Code	HAEGER® Part Number		PEMSERTER® Part Number		Anvil Dimensions (in.)					
		Anvil	Punch	Anvil	Punch	A +0.03 - .000	B ±.002	C ±.002	P ±.001	R1 Max.	R2 Max.
	440	H-181-4L	H-108-0020L	8001645	975200048	.113	.144	.174	.101	.003	.005
632	H-181-6L	H-108-0020L	8001644	975200048	.140	.170	.200	.10	.003	.005	
832	H-181-8L	H-108-0020L	8001643	975200048	.166	.202	.236	.10	.003	.005	
032	H-181-10L	H-108-0020L	8001642	975200048	.191	.235	.275	.10	.003	.005	
0420	H-181-04L	H-108-0020L	8002535	975200048	.252	.324	.360	.020	.003	.005	

Metric	Thread Code	HAEGER® Part Number		PEMSERTER® Part Number		Anvil Dimensions (mm)					
		Anvil	Punch	Anvil	Punch	A ±0.08	B ±0.05	C ±0.05	P ±0.025	R1 Max.	R2 Max.
	M3	H-181-M3L	H-108-0020L	8001678	975200048	3.05	3.81	4.57	0.25	0.08	0.13
M4	H-181-M4L	H-108-0020L	8001677	975200048	4.04	4.95	5.82	0.25	0.08	0.13	
M5	H-181-M5L	H-108-0020L	8001676	975200048	5.08	6.15	7.16	0.25	0.08	0.13	
M6	H-181-M6L	H-108-0020L	8002536	975200048	6.05	7.87	8.79	0.51	0.08	0.13	

Installation

SGPC™ Studs

1. Prepare properly sized mounting hole in sheet.
2. Insert fastener through mounting hole (punch side) as shown in drawing.
3. With installation punch and anvil surfaces parallel, apply squeezing force until the punch pushes over the protruding knurls of the stud.

Installation Tooling

Unified	Thread Code	Punch Dimensions (in.)		Punch Part Number ⁽¹⁾	Anvil Dimensions (in.)		Anvil Part Number ⁽¹⁾
		A +.004 -.000	B +.000 -.001	PEMSERTER®	C +.001	P +.000 -.002	PEMSERTER®
	256	.209	.019	8015111	.087	.014	8016983
440	.248	.022	8015112	.113	.014	8016984	
632	.276	.022	8015113	.139	.014	8016985	
832	.299	.022	8015114	.165	.014	8016986	
032	.327	.022	8015115	.191	.014	8016987	
0420	.386	.026	8015116	.251	.014	8016988	

Metric	Thread Code	Punch Dimensions (mm)		Punch Part Number ⁽¹⁾	Anvil Dimensions (mm)		Anvil Part Number ⁽¹⁾
		A +0.1	B -0.025	PEMSERTER®	C +0.025	P -0.05	PEMSERTER®
	M2.5	5.5	0.47	8015117	2.53	0.35	8016989
M3	6.5	0.57	8015118	3.03	0.35	8016990	
M4	7.5	0.57	8015119	4.03	0.35	8016991	
M5	8.5	0.57	8015120	5.03	0.35	8016992	
M6	9.5	0.67	8015121	6.03	0.35	8016993	

(1) [Click here](#) for a quote on Haeger® custom installation tooling.

NOTE: For panel design information, [click here](#).

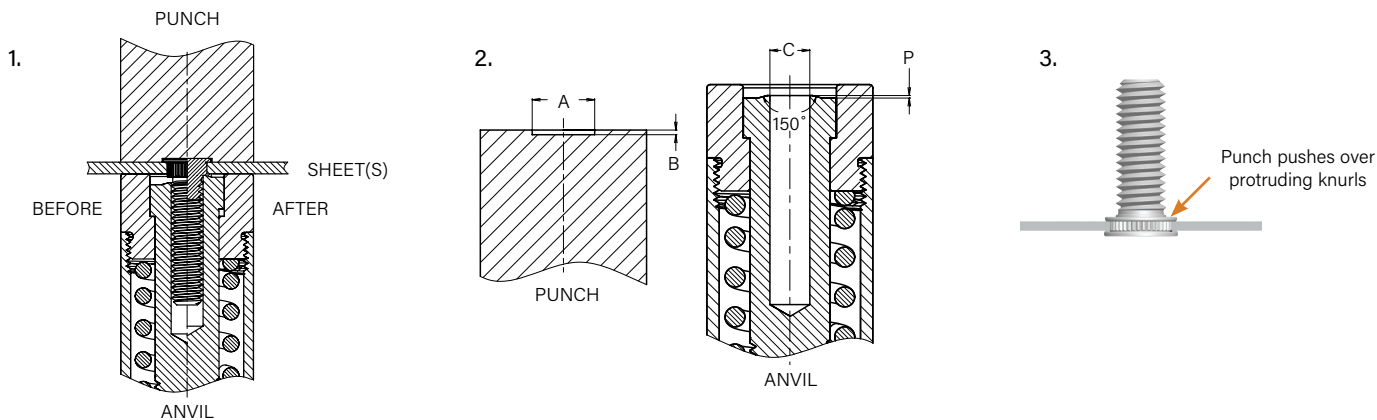

Installation

TP4™ Pins

1. Prepare properly sized mounting hole in sheet. Do not perform any secondary operations such as deburring.
2. Place pin end through mounting hole in sheet (punch side) and into anvil as shown
3. With installation punch and anvil surfaces parallel, apply squeezing force to embed the pin's head flush in the sheet.

Installation Tooling

Unified	Pin Dia. Code	Test Sheet Thickness (in.)	Anvil Dimensions (in.)		HAEGER® Part Number		PEMSERTER® Part Number	
			A ±.002	C ±.002	Anvil	Punch	Anvil	Punch
	125	.040 - .060 Over .060	.160 (1)	.130	H-106-125L-C	H-108-0020L	8003284	975200048
H-106-125L					H-108-0020L	8003278	975200048	
187	.040 - .065 Over .065	.220 (1)	.192	H-106-187L-C	H-108-0020L	8003285	975200048	
				H-106-187L	H-108-0020L	8003279	975200048	
250	.040 - .075 Over .075	.285 (1)	.255	H-106-250L-C	H-108-0020L	8003286	975200048	
				H-106-250L	H-108-0020L	8003280	975200048	

Metric	Pin Dia. Code	Test Sheet Thickness (mm)	Anvil Dimensions (mm)		HAEGER® Part Number		PEMSERTER® Part Number	
			A ±0.05	C ±0.05	Anvil	Punch	Anvil	Punch
	3MM	1 - 1.7 Over 1.7	3.88 (1)	3.11	H-106-3MML-C	H-108-0020L	8008096	975200048
H-106-3MML					H-108-0020L	8008095	975200048	
4MM	1 - 1.7 Over 1.7	4.88 (1)	4.11	H-106-4MML-C	H-108-0020L	8003287	975200048	
				H-106-4MML	H-108-0020L	8003281	975200048	
5MM	1 - 1.8 Over 1.8	5.89 (1)	5.13	H-106-5MML-C	H-108-0020L	8003288	975200048	
				H-106-5MML	H-108-0020L	8003282	975200048	
6MM	1 - 1.9 Over 1.9	6.89 (1)	6.12	H-106-6MML-C	H-108-0020L	8003289	975200048	
				H-106-6MML	H-108-0020L	8003283	975200048	

(1) Chamfered anvil not required.

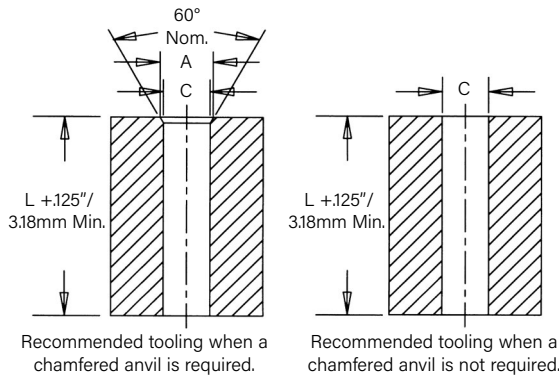

See page 12 for "L"

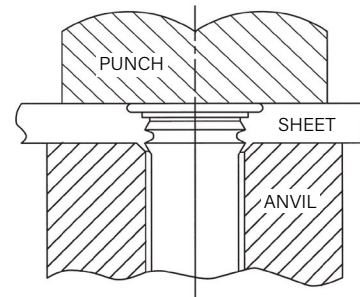

PFC4™ Captive Panel Screws

1. Prepare properly sized mounting hole in sheet. Do not perform any secondary operations such as deburring.
2. Place fastener into the anvil hole and place the mounting hole (punch side) over the shank of the fastener retainer.
3. With installation punch and anvil surfaces parallel, apply squeezing force until the shoulder of the retainer comes in contact with the sheet material.

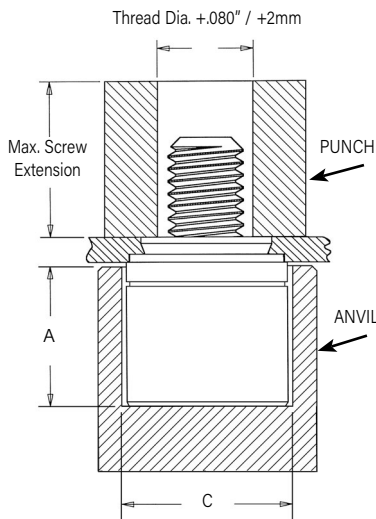

Installation Tooling⁽¹⁾⁽²⁾

Unified	Thread Code	PEMSERTER® Part Number		Anvil Dimensions (in.)	
		Anvil	Punch	A ±.002	C ±.002
	440	975200027	975200060	.345	.358
	632	975201243	975200061	.345	.390
	832	975200029	975200062	.435	.421
	032	975201244	975200063	.435	.452

Metric	Thread Code	PEMSERTER® Part Number		Anvil Dimensions (mm)	
		Anvil	Punch	A ±0.05	C ±0.05
	M3	975200027	975200060	8.76	9.09
	M4	975200029	975200062	11.05	10.69
	M5	975201244	975200063	11.05	11.48

(1) Punches and anvils should be hardened.

(2) [Click here](#) for a quote on Haeger® custom installation tooling.

Installation

SFP™ Fasteners

1. Prepare properly sized mounting hole in both panels. Do not perform any secondary operations such as deburring.
2. Place Panel 2 with smaller mounting hole on anvil and align Panel 1 mounting hole with the mounting hole of Panel 2. Place the smaller diameter end of the fastener through the mounting holes as shown in the drawing to the right.
3. With installation punch and anvil surfaces parallel, apply squeezing force until the fastener is flush with the top of Panel 1.

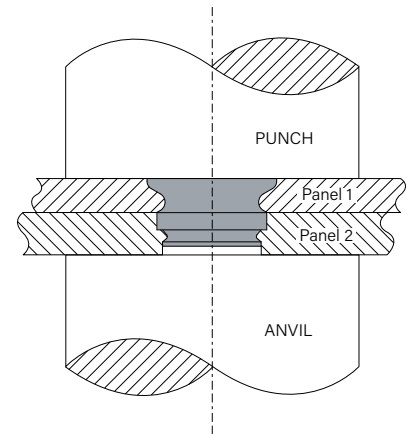

NOTE: To use as a flush-mounted pivot point, for best results, install SpotFast® fastener into Panel 1 first, then place Panel 2 over fastener and squeeze again.

Installation Tooling

Size	HAEGER® Part Number		PEMSERTER® Part Number	
	Anvil	Punch	Anvil	Punch
SFP-3/SFP-5	H-108-0019L	H-108-0019L	975200046	975200048

Installation Notes

- For best results we recommend using a PEMSERTER® press for installation of PEM® self-clinching fasteners. Please check our website for more information.
- Visit the Animation Library on our website to view the installation process [for select products](#).



For Additional HAEGER® and PEMSERTER® Tooling Information/Part Numbers visit our [tooling wizard](#)



Performance Data⁽¹⁾

SP™ Nuts

Unified	Type	Thread Code	Shank Code	Test Sheet Material	Installation (lbs.)	Pushout (lbs.)	Torque-out (in. lbs.)
	SP	256		0	304 Stainless Steel	8000	130
1				9000		165	17
2				10000		290	18
SP	440		0	304 Stainless Steel	8000	130	14
			1		9000	165	17
			2		10000	290	18
SP	632		0	304 Stainless Steel	8500	140	18
			1		9500	170	24
			2		10500	340	28
SP	832		0	304 Stainless Steel	9000	145	30
			1		10000	180	37
			2		11000	360	45
SP	024/032		0	304 Stainless Steel	9500	180	35
			1		10500	230	45
			2		11500	400	60
SP	0420		1	304 Stainless Steel	13500	450	150
			2		13500	600	170
SP	0518		1	304 Stainless Steel	14800	470	170
			2		18000	750	250
SP	0524		1	304 Stainless Steel	14800	470	170
			2		18000	750	250
SP	0616/0624		1	304 Stainless Steel	16000	600	300
			2		20000	700	370

Metric	Thread Code	Shank Code	Test Sheet Material		
			304 Stainless Steel		
			Installation (kN)	Pushout (N)	Torque-out (N-m)
M2		1	40	725	1.92
		2	44.5	1290	2.03
M2.5		0	35.6	575	1.58
		1	40	725	1.92
		2	44.5	1290	2.03
M3		0	35.6	575	1.58
		1	40	725	1.92
		2	44.5	1290	2.03
M4		0	40	645	3.38
		1	44.5	800	4.18
		2	49	1600	5.08
M5		0	42.3	800	3.95
		1	46.7	1025	5.08
		2	51.2	1775	6.77
M6		1	60	2000	17
		2	60	2600	19
M8		1	66	2100	19
		2	80	4500	23
M10		1	80	2150	38

SMPP™ Nuts

Unified	Thread Code	Max. Nut Tightening Torque (in. lbs.) (2) (3)	Test Sheet Thickness and Material (in.)	Sheet Hardness HRB	Installation (lbs.) (4)	Pushout (lbs.)	Torque-out (in. lbs.)	Tensile Strength (lbs.) (2) (3)	Test Bushing Hole Size For Pull Thru Tests (in.)
	256	7.5	.029" 304 Stainless Steel	89	4500	50	10	640	.104
440	13	.029" 304 Stainless Steel	89	4500	75	15	850	.112	
632	20	.029" 304 Stainless Steel	89	6000	75	20	1020	.138	

Metric	Thread Code	Max. Nut Tightening Torque (N-m) (2) (3)	Test Sheet Thickness and Material (mm)	Sheet Hardness HRB	Installation (kN) (4)	Pushout (N)	Torque-out (N-m)	Tensile Strength (kN) (2) (3)	Test Bushing Hole Size For Pull Thru Tests (mm)
	M2.5	1.05	0.7 mm 304 Stainless Steel	89	20	200	1.35	3.05	3
M3	1.5	0.7 mm 304 Stainless Steel	89	20	300	1.85	3.63	3.5	
M3.5	2.1	0.7 mm 304 Stainless Steel	89	27	300	1.9	4.25	4	

A4™/LA4™ Nuts

Unified	Thread Code	Test Sheet Material		
		300 Series Stainless Steel		
		Installation (lbs.)	Retainer Pushout (lbs.)	Retainer Torque-out (in. lbs.)
440		9000	200	85
632		10000	200	85
832		12000	200	85
032		13000	250	125

Metric	Thread Code	Test Sheet Material		
		300 Series Stainless Steel		
		Installation (kN)	Retainer Pushout (N)	Retainer Torque-out (N-m)
M3		40	890	9.6
M4		53	890	9.6
M5		57	1100	14.1

- (1) Published installation forces are for general reference. Actual set-up and confirmation of complete installation should be made by observing proper seating of fastener as described in the installation steps. Other performance values reported are averages when all proper installation parameters and procedures are followed. Variations in mounting hole size, sheet material, and installation procedure may affect performance. Performance testing this product in your application is recommended. We will be happy to provide technical assistance and/or samples for this purpose.
- (2) Head size is adequate to ensure failure in threaded area when tested with industry standard tensile bushing diameter.
- (3) Tightening torque shown will induce preload of 70% of nut min axial strength with K or nut factor is equal to 0.20. In some applications tightening torque may need to be adjusted based on the actual K value. All tightening torques shown are based on 180 ksi/ Property Class 12.9 screws. For lower strength screws the tightening torque is proportionately less. For example, for 120 ksi screws, torque is 67% value shown. For 900 MPa screws (Property Class 9.8) torque value is 74% of value shown.
- (4) Installation controlled by proper cavity depth in punch.

Performance Data

F4™ Nuts

Unified	Thread Code	Shank Code	Axial Tensile Strength (lbs.) (1)	Max. Screw Tightening Torque (2) (in. lbs.)	Test Sheet Material	
					300 Series Stainless Steel	
					Installation (lbs.)	Pushout (lbs.)
256		1	130	1.50	7200	270
		2				
440		1	165	2.50	7200	270
		2				
632		1	190	3.50	7200	290
		2				
832		1	230	5.25	9000	450
		2				
032		1	280	7.50	9000	450
		2				
0420		3	1035	36	14000	1000
		4				
		5				

Metric	Thread Code	Shank Code	Axial Tensile Strength (kN) (1)	Max. Screw Tightening Torque (2) (N-m)	Test Sheet Material	
					300 Series Stainless Steel	
					Installation (kN)	Pushout (N)
M2		1	0.57	0.16	32	1200
		2				
M2.5		1	0.68	0.23	32	1200
		2				
M3		1	0.85	0.36	32	1200
		2				
M4		1	1	0.58	40	2000
		2				
M5		1	1.3	0.88	40	2000
		2				
M6		3	4.5	3.7	65	4500
		4				
		5				

SO4™/BSO4™ Standoffs

Unified	Thread Code	Max. Rec. Tightening Torque For Mating Screw (in. lbs.)	Test Sheet Material			
			.050" 300 Series Stainless Steel			
			Installation (lbs.)	Pushout (lbs.)	Torque-out (in. lbs.) (3)	Pull-thru (lbs.) (3)
440		4.75	5500	336	17	600
6440		4.75	9500	647	30	680
632		8.75	9500	647	30	680
8632		8.75	10500	900	71	1392
832		18	10500	900	71	1517
032		32	10500	900	71	1368

Metric	Thread Code	Max. Rec. Tightening Torque For Mating Screw (N-m)	Test Sheet Material			
			1.3 mm 300 Series Stainless Steel			
			Installation (kN)	Pushout (N)	Torque-out (N-m) (3)	Pull-thru (N) (3)
M3		0.55	24.5	1493	2.36	2650
3.5M3		0.55	42.3	2877	3.06	3025
M3.5		0.91	42.3	2877	3.06	3025
M4		2	46.7	4003	8.89	6458
M5		3.6	46.7	4003	8.89	6226

TSO4™ Standoffs

Standoff "C" Dimension	Test Sheet Material					
	.025" / 0.64 mm 300 series stainless steel					
	Installation		Pushout		Torque-out (3)	
	(lbs.)	(kN)	(lbs.)	(N)	(in. lbs.)	(N-m)
.165" / 4.2 mm	5700	25.4	125	555	13	1.5
.212" / 5.39 mm	6800	30.3	160	710	22	2.5

FH4™ Studs

Unified	Thread Code	Recommended Nut Tightening Torque (in. lbs.) (5)	Sheet Hardness HRB	Test Sheet Material			
				.060" Stainless Steel (4)			
				Installation (lbs.)	Pushout (lbs.)	Torque-out (in. lbs.)	Pull-thru (lbs.)
440		11	87	9000	450	16	800
632		22	87	9500	540	27	1350
832		35	86	11200	780	58	1800
032		51	86	12000	800	95	2250
0420		117	86	23000	1600	156	3900

Metric	Thread Code	Recommended Nut Tightening Torque (N-m) (5)	Sheet Hardness HRB	Test Sheet Material			
				1.5 mm Stainless Steel (4)			
				Installation (kN)	Pushout (N)	Torque-out (N-m)	Pull-thru (N)
M3		1.3	87	40	2220	1.8	3500
M4		3.8	86	50	3210	6.5	8000
M5		6	86	53	3560	10.7	10000
M6		11	86	100	4200	15.9	14900

- (1) Failure occurs in screw stripping using a 60 ksi screw and the shortest shank length fastener.
- (2) Torque values shown will produce a preload of 70% of axial tensile strength with nut factor "k" equal to .2. Threads may strip or head of the nut may bend and/or fail if screw is over-torqued beyond these values or if actual k value is less than .2.
- (3) Joint failure in torque-out and pull-thru will depend on the strength and type of screw being used. In some cases the failure will be in the screw and not in the self-clinching standoff. Please contact our Applications Engineering group with any questions.
- (4) Performance may be reduced for studs installed into thicker sheets.
- (5) Tightening torque shown is a theoretical value calculated to induce a load of 75% of minimum axial yield strength of the stud with an assumed K.

Performance Data

FHP™ Studs

Unified	Thread Code	Recommended Nut Tightening Torque (in. lbs.) (2)	Sheet Hardness HRB	Test Sheet Material			
				.060" Stainless Steel (1)			
				Installation (lbs.)	Pushout (lbs.)	Torque-out (in. lbs.)	Pull-thru (lbs.)
440	8.1	86	9000	520	10.6	605	
632	16	86	9500	670	19.5	940	
832	28	86	11200	785	37.5	1415	
032	34	86	12000	800	59.5	1500	

Metric	Thread Code	Recommended Nut Tightening Torque (N-m) (2)	Sheet Hardness HRB	Test Sheet Material			
				1.5 mm (for M4&M5) 2 mm (for M3) Stainless Steel (1)			
				Installation (kN)	Pushout (N)	Torque-out (N-m)	Pull-thru (N)
M3	1.3	86	40	2500	1.6	3500	
M4	2.9	86	50	3000	3.9	6000	
M5	4.4	86	53	3560	7.35	7320	

SGPC™ Studs

Unified	Thread Code	Max. Rec. Tightening Torque For Mating Nut (in. lbs.)	Sheet Hardness HRB	Test Sheet Material			
				Single sheet of .039" 300 Series Stainless Steel			
				Installation (lbs.)	Pushout (lbs.)	Torque-out (in. lbs.)	Pull-thru (lbs.)
256	2.3	92	4000	425	5.2	415	
440	5	92	5000	450	8	512	
632	9	92	5500	460	15.8	811	
832	17	92	6500	480	29.3	1133	
032	27	92	7300	545	42.8	1273	
0420	58	92	10000	565	76.7	1721	

Metric	Thread Code	Max. Rec. Tightening Torque For Mating Nut (N-m)	Sheet Hardness HRB	Test Sheet Material			
				Single sheet of 1 mm 300 Series Stainless Steel			
				Installation (kN)	Pushout (N)	Torque-out (N-m)	Pull-thru (N)
M2.5	0.41	92	20.1	2546	0.86	2561	
M3	0.74	92	21.8	2051	1.35	2851	
M4	1.7	92	28.5	2396	2.66	4000	
M5	3.5	92	35.6	3200	5.96	4284	
M6	5.9	92	42.3	3262	9.19	6311	

TP4™ Pins

Unified	Pin Diameter Code	Test Sheet Material	
		300 Series Stainless Steel	
		Installation (lbs.)	Pushout (lbs.)
125		8000	350
187		12000	570
250		14000	650

Metric	Pin Diameter Code	Test Sheet Material	
		300 Series Stainless Steel	
		Installation (kN)	Pushout (N)
3MM		35	1556
4MM		45	2335
5MM		54	2535
6MM		60	2891

PFC4™ Captive Panel Screws

Unified	Thread Code	Test Sheet Material	
		300 Series Stainless Steel	
		Installation (lbs.)	Retainer Pushout (lbs.)
440		9100	350
632		10300	400
832		10800	450
032		11800	550

Metric	Thread Code	Test Sheet Material	
		300 Series Stainless Steel	
		Installation (kN)	Retainer Pushout (N)
M3		40.5	1557
M4		48	2002
M5		52.5	2447

SFP™ Fasteners

Type and Size	Thickness Code	Test Sheet Material			
		Stainless Steel			
		Installation		Pushout of Panel 2 (3)	
		kN	lbs.	N	lbs.
SFP-3	1.0	13.5	3000	620	140
SFP-3	1.2	20	4500	830	186
SFP-3	1.6	22	5000	1500	340
SFP-5	1.0	18	4000	990	222
SFP-5	1.2	27	6000	1158	260
SFP-5	1.6	33	7500	3117	701

(1) Performance may be reduced for studs installed into thicker sheets.
 (2) Tightening torque shown is a theoretical value calculated to induce a load of 75% of minimum axial yield strength of the stud with an assumed K.
 (3) In most applications, pullout strength of the SpotFast® fastener in Panel 1 exceeds pushout strength of Panel 2.

Other Fasteners For Consideration To Use In Stainless Steel Sheets

PF11MW™ Captive Panel Screws

Floating captive panel screw with unique flare-mount feature allows fastener to "float" in mounting hole and compensate for mating thread alignment. (See PEM® [PF Datasheet](#))

**PF11MF™ Captive Panel Screws**

Flare-mounted captive panel screw that installs into any panel material and is flush on back side of panel. (See PEM® [PF Datasheet](#))

**MPP™ Pins**

Self-clinching microPEM® pins that can be installed into stainless steel sheets as thin as .02"/0.5mm. (See PEM® [MPF Datasheet](#))

**MSO4™ Standoffs**

Self-clinching microPEM® standoffs that can be installed into stainless steel sheets as thin as .016"/0.4mm. (See PEM® [MPF Datasheet](#))

**T4™ Tackpin® Fasteners**

microPEM® TackPin® fasteners enable sheet-to-sheet attachment in stainless steel sheets in applications where disassembly is not required. (See PEM® [MPF Datasheet](#))

**WN/WNS Weld Nuts**

Designed to overcome many problems such as burn-outs, complicated electrodes and pilots, indexing and re-tapping to remove weld spatter. (See PEM® [WN Datasheet](#))

**ATLAS® Blind Threaded Inserts**

Attach to panels of any hardness and provide strong and reusable permanent threads in sheet materials where only one side is accessible. (See [ATLAS® Catalog](#))

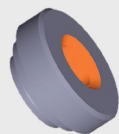

Fastener drawings and models are available at www.pemnet.com

Custom sizes are available on special order. [Contact us](#) for more information.

Installation Into Stainless Steel Sheets Dos And Don'ts

"DOS"

- DO** select the proper fastener material to meet corrosion requirements.
- DO** make certain that panel material is in the annealed condition.
- DO** make certain that hole punch is kept sharp to minimize work hardening around hole.
- DO** provide mounting hole of specified size for each fastener.
- DO** maintain the hole punch diameter to no greater than $+0.001"/.025$ mm over the minimum recommended mounting hole.
- DO** make certain that fastener is properly positioned within hole before applying installation force.
- DO** make certain that fastener is not installed adjacent to bends or other highly cold-worked areas.
- DO** apply squeezing force between parallel surfaces.
- DO** utilize recommended installation tooling when installing fasteners.
- DO** install fastener in punched side of hole.
- DO** apply sufficient force to totally embed clinching ring (where applicable) around entire circumference and to bring shoulder squarely in contact with sheet. For all other fasteners, installation will be complete when the head is flush with the panel surface.

"DON'TS"

- DON'T** attempt to install any self-clinching fastener other than types SP, SMPP, A4, LA4, F4, SO4, BSO4, TSO4, FH4, FHP, SGPC, TP4, PFC4, and SFP into a stainless steel sheet.
- DON'T** deburr mounting holes on either side of sheet before installing fasteners – deburring will remove metal required for clinching fastener into sheet.
- DON'T** install fastener closer to edge of sheet than minimum edge distance – unless a special fixture is used to restrict bulging of sheet edge.
- DON'T** install fastener near bends or other highly cold worked areas where sheet hardness may be greater than the limit for the fastener.
- DON'T** over-squeeze. It will crush the head, distort threads, and buckle the sheet. Be certain to determine optimum installation force by test prior to production runs.
- DON'T** attempt to insert fastener with a hammer blow – under any circumstances. A hammer blow won't permit the sheet metal to flow and develop an interlock with the fastener's contour.
- DON'T** install screw in the head side of fastener. Install from opposite side so that the fastener load is toward sheet. The clinching force is designed only to hold the fastener during handling and to resist torque during assembly.

All PEM® products meet our stringent quality standards. If you require additional industry or other specific [quality certifications](#), special procedures and/or part numbers are required. Please contact your local sales office or representative for further information.

Regulatory [compliance information](#) is available in Technical Support section of our website. Specifications subject to change without notice. See our website for the most current version of this bulletin.



North America: Danboro, Pennsylvania USA | E-mail: info@pemnet.com | Tel: +1-215-766-8853 | 800-237-4736 (USA)

Europe: Galway, Ireland | E-mail: europa@pemnet.com | Tel: +353-91-751714

Asia/Pacific: Singapore | E-mail: singapore@pemnet.com | Tel: +65-6-745-0660

Kunshan, China: E-mail: salesgreaterchina@pemnet.com | Tel: +86-512-5276-9300

Visit our PEMNET™ Resource Center at www.pemnet.com • Technical support e-mail: techsupport@pemnet.com