



PEM® CONSUMER ELECTRONICS FASTENING DESIGN STANDARDS



Discover the Difference

- Micro-sized parts available off the shelf
- One single part number, anywhere in the world

SEE HOW THE INNOVATIVE THINKING BEHIND PEM® FASTENING SOLUTIONS CAN MOVE YOU FORWARD

Consumer electronics manufacturers rely on the forward-thinking innovation and high performance of PEM® and microPEM® fasteners. You'll find our products everywhere – from laptops and virtual reality glasses to trackpads and keyboards.

PEM® brand fasteners use self-clinching, broaching, flaring, or surface mount technology for strong, reusable, and permanent threads and mounting points in different ductile/non-ductile materials.

microPEM® brand fasteners go beyond the ability of traditional micro screws – providing a thinner, lighter, stronger solution for practically any consumer electronics micro application.

With new capabilities and one of the largest and most diverse portfolios in the industry, see how you can move forward with better cost savings, reliability, and eco-friendly performance for your products.

DISCOVER THE DIFFERENCE WITH PEM® AND MICROPEM® CONSUMER ELECTRONICS FASTENERS

PEM® and microPEM® solutions give you thinner, stronger, lighter fasteners – a winning combination that delivers better performance and a competitive advantage.

One Single Part Number, Anywhere in the World

We offer one single part number for each of our standard parts, making it easy for you to order while increasing product availability.

Micro-sized Parts Available Off the Shelf

Our extensive portfolio of standard parts is ready, directly off the shelf, to help you reduce your critical lead times supporting new designs.

PEMedge® Value Add Services

PEMedge® is a full suite of expert services to help you improve cost, quality, time to market, and overall performance. Services include:

[Teardowns](#) | [Testing](#) | [Application Engineering](#) | [Virtual Tech Support](#) | [Master Classes](#).

Table of Contents

Click links below for shortcuts to information.

- [PEM®/ microPEM® Innovation](#)
- [Consumer Electronics Applications:](#)
 - [Laptops](#)
 - [Wearables](#)
 - [Smart Phones](#)
 - [Internet of Things \(IoT\)](#)
- [microPEM® Fasteners:](#)

WHY CHOOSE PEM® FASTENERS

PennEngineering® was founded on a single revolutionary product – an easy-to-install, self-clinching fastener that provides load-carrying threads in metal sheets too thin to be tapped.

Today, PEM® fasteners include hundreds of innovative products that provide hundreds of design applications – with unmatched quality, performance, and reliability.

FEWER PARTS. FEWER ASSEMBLY STEPS. FASTER TIME TO MARKET

PEM® and microPEM® fasteners attach to a sheet of ductile material by causing the material to cold-flow under pressure into an annular recess of the fastener – securely locking it into place.

Strength – Stronger threads vs. a tapped panel

In-Process Installation – Parts are installed into a plain round hole with no secondary operations required

Cost Reduction – Decreased installation cycle times with high-speed installation options

Design Flexibility – Can be installed into dissimilar metals

Clean Process – Environmentally friendly, with no weld splatter and less energy requirements

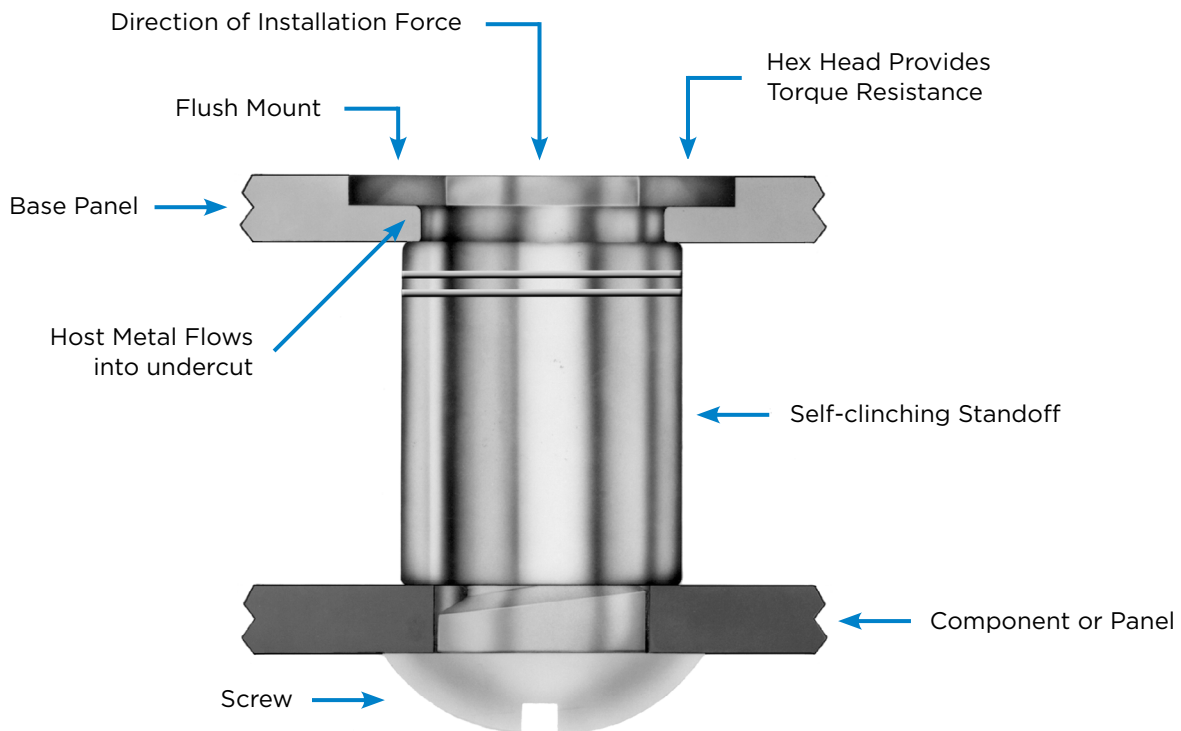

DESIGN ENGINEERED FOR CRITICAL CONSUMER ELECTRONICS APPLICATIONS

The complexity and reduced size of electronics products continues to grow every day, and fasteners have become a critical piece of consumer electronics architecture.

PEM® and microPEM® fasteners play a critical role in the performance of products. Whether it's a standard catalog fastener, custom part, or total system solution, our engineering expertise makes it possible to design an innovative fastening solution for any application.

THINNER, LIGHTER, STRONGER SOLUTIONS THAT GO BEYOND THE ABILITY OF SCREWS

While traditional micro screws can hold multiple components together, they can be an expensive option when considering total installation cost.

The Tack family of fasteners are a smart alternative that can save you money and perform better than traditional screws:

- Smaller size and lighter for consumer electronics
- Designed for thinner applications and sleek cosmetic profile
- Lower total installed cost
- Better process control

TACK FAMILY OF FASTENERS

TackPin®

- Suitable for installation into ductile materials
- Ideal for machined aluminum or steel HRB 88 or less

TackScrew™

- Suitable for installation into ductile materials
- Ideal for machined aluminum or steel HRB 88 or less
- Allows for re-usability by unscrewing and reinstallation

TackSert®

- Suitable for installation into brittle materials
- Ideal for plastic or metal castings

FlexTack™

- Suitable for installation into ductile materials
- Ideal for machined aluminum HRB 50 or less
- The Belleville-shaped head allows for stack-up tolerance relief.

TackPin®, TackScrew™, FlexTack™ are patented. ClampDisk® and TackSert® are patent pending.

Table of Contents

Click links below for shortcuts to information.

- [PEM®/ microPEM® Innovation](#)
- [Consumer Electronics Applications:](#)
 - [Laptops](#)
 - [Wearables](#)
 - [Smart Phones](#)
 - [Internet of Things \(IoT\)](#)
- [microPEM® Fasteners:](#)

Surface Mount Fastener

MicroScrew

ZackSert™ Fastener

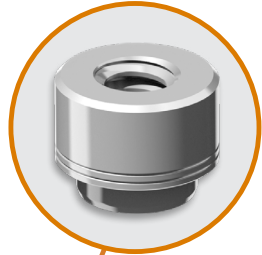
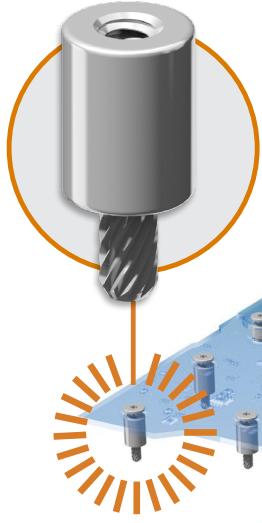

Internal/External Fastener

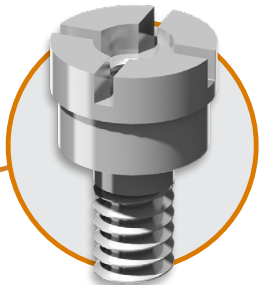

Self-Clinching Standoff

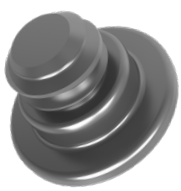
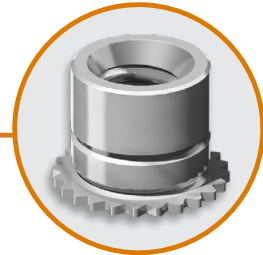

TackPin®

TackScrew™

TackSert®

FlexTack™

Table of Contents

Click links below for shortcuts to information.

- [PEM®/ microPEM® Innovation](#)
- [Consumer Electronics Applications:](#)
 - [Laptops](#)
 - [Wearables](#)
 - [Smart Phones](#)
 - [Internet of Things \(IoT\)](#)
- [microPEM® Fasteners:](#)

SEE WHAT'S POSSIBLE WITH PEM® FASTENING SOLUTIONS

LAPTOPS

From keyboard attach to trackpads to PCB attach, PEM® fastening solutions ensure top performance.

Sample Applications

- Keyboard Attach
- Trackpad Attach
- Thin Sheet Enclosure Mounts
- PCB Attach
- Cosmetic Enclosure Standoffs

PEM® Solutions

- [microPEM® TackSert® Fastener](#)
- [microPEM® TackPin® Fastener](#)
- [microPEM® Self-clinching Pins](#)
- [microPEM® Self-clinching Standoffs](#)
- [microPEM® Surface Mount Fasteners](#)
- [SI® Molded Insert](#)
- [ZackSert™ Fastener](#)
- [Internal/External Fasteners](#)



WEARABLES

PEM® fastening solutions can be used to provide lightweight, strong attachment for wearables applications.

Sample Applications

- Vibrational Motor Attach
- PCB Mounting
- Charge Pins
- Thin Sheet Substructures
- Strong Threads for Cast Magnesium or Aluminum
- Hinge Connections
- Band and Strap Connections

PEM® Solutions

- [microPEM® TackSert® Fastener](#)
- [microPEM® TackPin® Fastener](#)
- [microPEM® Self-clinching Pins](#)
- [microPEM® Surface Mount Fasteners](#)
- [SI® Molded Insert](#)
- [Internal/External Fasteners](#)

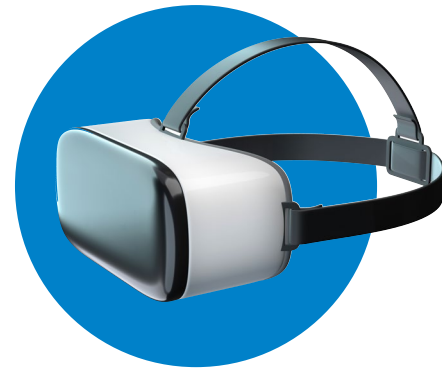

SOLUTIONS FOR CONSUMER ELECTRONICS

SMART PHONES & TABLETS

From thin back enclosure standoffs to pick and place surface mount components, PEM® fasteners can save space and reduce overall weight while maintaining a strong structural joint.

Sample Applications

- PCB Attachment
- Thin Sheet Attach on Cosmetic
- Surfaces
- Strong Threads for Aluminum
- Enclosures

PEM® Solutions

[microPEM® TackSert® Fastener](#)

[microPEM® TackPin® Fastener](#)

[microPEM® Self-clinching Standoffs](#)

[Internal/External Fasteners](#)

[microPEM® Surface Mount Fasteners](#)



INTERNET OF THINGS (IoT)

PEM® solutions deliver reliability to connectivity and telematics systems, vehicle instrumentation, audio and video components, gaming electronics, and more.

Sample Applications

- PCB Attachment
- Thin Sheet Support Substructures
- Battery Shielding
- Vibration-Resistant Speaker Mounting

PEM® Solutions

[microPEM® Self-clinching Standoffs](#)

[microPEM® TackPin® Fastener](#)

[Internal/External Fasteners](#)

[microPEM® Surface Mount Fasteners](#)



EXPERTISE TO TAKE YOU FURTHER

Not only are PEM® and microPEM® fastening solutions precisely designed and manufactured, but they're backed by expert technical support services. So you can always be confident in our product quality and reliability.

- Application Engineering Services & Tools
- Technical Lab Services & Testing
- Prototype Development Center
- Installation Equipment Solutions
- Global Manufacturing Network

Table of Contents

Click links below for shortcuts to information.

- [PEM®/ microPEM® Innovation](#)
- [Consumer Electronics Applications:](#)
 - [Laptops](#)
 - [Wearables](#)
 - [Smart Phones](#)
 - [Internet of Things \(IoT\)](#)
- [microPEM® Fasteners:](#)

NEED INFORMATION ON A SPECIFIC PEM® FASTENER? BROWSE OUR CONSUMER ELECTRONICS CATALOG

To see our full range of fastening solutions, visit PEMnet.com.

For help with technical information or samples, call **800-342-5736** or email info@pemnet.com.

GET PEM® AND MICROPEM® PARTS AND SUPPORT ANYTIME, ANYWHERE



CONSUMER ELECTRONICS FASTENER CATALOG

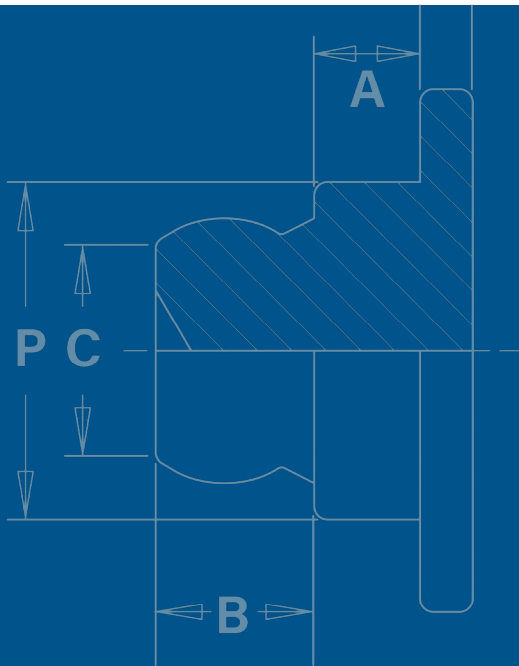

The following pages contain our portfolio of PEM® and microPEM® fasteners for consumer electronics applications.

- One single part number, anywhere in the world
- Micro-sized parts available off-the-shelf on all standard parts

PEM® FASTENERS

The innovation behind PEM® and microPEM® fastening solutions can add significant value and cost savings to your most complex applications requirements. Our portfolio is one of the largest and most diverse in the industry.

Table of Contents

Click links below for shortcuts to information.

- [PEM®/ microPEM® Innovation](#)
- [Consumer Electronics Applications:](#)
 - [Laptops](#)
 - [Wearables](#)
 - [Smart Phones](#)
 - [Internet of Things \(IoT\)](#)
- [microPEM® Fasteners:](#)
 - [MPP™ Self-clinching Pin](#)
 - [MSO4™ Self-clinching Standoffs](#)
 - [TA™/T4™ TackPin® Fasteners](#)
 - [TS4™ TackScrew™ Fasteners](#)
 - [TKA™/TK4™ TackSert® Pins](#)
 - [TFA™ FlexTack™ Fasteners](#)
 - [CDS™ ClampDisk® Fasteners](#)
 - [MSIA™/MSIB™ Inserts For Plastic](#)
 - [MSOFS™ Flaring Standoffs](#)
 - [SMTSO™ Surface Mount Fasteners](#)
- [Capabilities](#)



[MPP™ microPEM® Self-clinching Pins](#)



[MSO4™ microPEM® Self-clinching Standoffs](#)

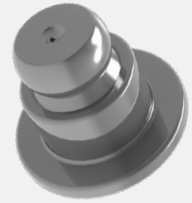

[TA™/T4™ microPEM® TackPin® Fasteners](#)

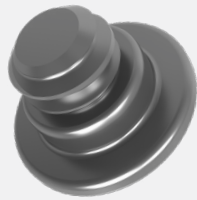

[TS4™ microPEM® TackScrew™ Fasteners](#)



[TKA™/TK4™ microPEM® TackSert® Pins](#)

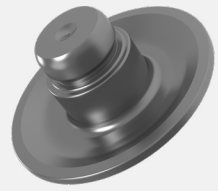

[TFA™ microPEM® FlexTack™ Fasteners](#)

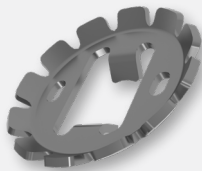

[CDS™ microPEM® ClampDisk® Fasteners](#)

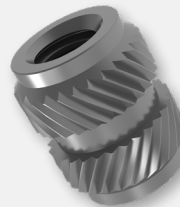

[MSIA™/MSIB™ SI® Inserts for Plastics](#)

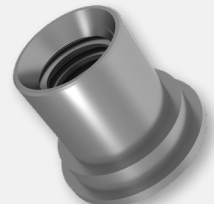

[MSOFS™ microPEM® Flaring Standoffs](#)

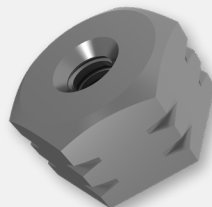

[SMTSO™ microPEM® Surface Mount Fasteners](#)



[Internal/External Fastener with External Drive](#)

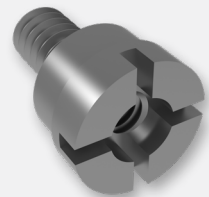

[Internal/External Fastener with Internal Cross Drive](#)



[Microscrew](#)



[ZackSert™ Fastener](#)

Ideal for Today and Tomorrow's Compact Electronics

MPP™ microPEM® SELF-CLINCHING PINS



- Satisfy demanding micro positioning and alignment applications
- Head mounts flush into panels as thin as 0.5 mm / .020"
- Chamfered end makes mating hole alignment easy
- Can be installed into stainless steel sheets
- Excellent corrosion resistance
- Can be installed automatically

PART NUMBER DESIGNATION

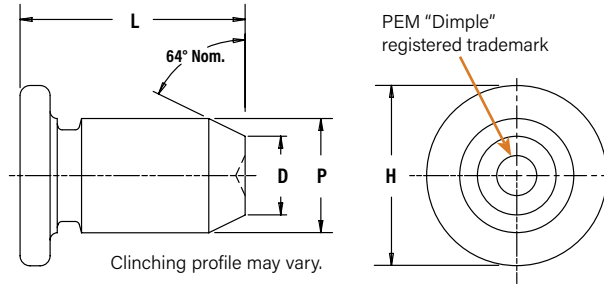
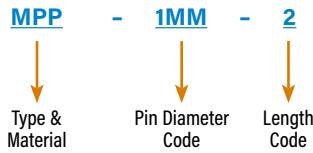

Pin Diameter P ±0.038mm	Type Stainless Steel	Pin Diameter Code	Length Code "L" ± 0.15 mm (Length Code in millimeters)							Min. Sheet Thickness		Hole Size In Sheet +0.025 mm / +.001"		D ±0.1 mm / ±.004"		H ±0.25 mm / ±.010"		Min. Distance Hole to Edge	
			2	3	4	5	-	-	-	mm	in.	mm	in.	mm	in.	mm	in.	mm	in.
1	MPP	1MM	2	3	4	5	-	-	-	0.5	.020	1.05	.041	0.7	.028	1.6	.063	2.05	.081
1.5	MPP	1.5MM	-	3	4	5	6	8	-	0.5	.020	1.55	.061	1.03	.041	2.24	.088	2.6	.102
2	MPP	2MM	-	-	4	5	6	8	10	0.5	.020	2.05	.081	1.36	.054	3.02	.119	4.4	.173

MSO4™ microPEM® SELF-CLINCHING STANDOFFS

- Designed for mounting and/or spacing in extremely limited space applications
- Can be installed into stainless steel sheets(1)
- Have stronger threads than weld standoffs because they are made from heat-treated 400 Series Stainless Steel
- Can be installed automatically



PART NUMBER DESIGNATION

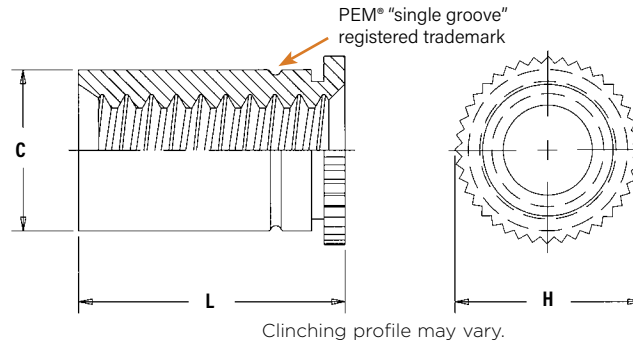
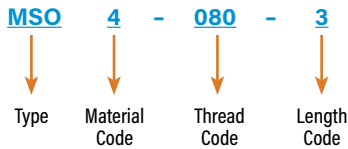

All dimensions are in inches.

UNIFIED	Thread Size	Type	Thread Code	Length Code	Min. Sheet Thickness	Hole Size In Sheet +.002 -.000	C Max.	H Nom.	L +.002 -.003	Min. Dist. Hole To Edge
		Stainless Steel								
	.060-80 (#0-80) (2)	MS04	080	3	.012	.095	.094	.125	.094	.090
				4					.125	
	.086-56 (#2-56) (2)	MS04	256	3	.012	.125	.124	.156	.094	.120
				4					.125	

All dimensions are in millimeters.

METRIC	Thread Size	Type	Thread Code	Length Code	Min. Sheet Thickness	Hole Size In Sheet +0.05	C Max.	H Nom.	L +0.05 - 0.08	Min. Dist. Hole To Edge
		Stainless Steel								
	M1 x 0.25 (3)	MS04	M1	2	0.3	2.41	2.39	3.18	2	2.3
				3					3	
	M1.2 x 0.25 (3)	MS04	M1.2	2	0.3	2.41	2.39	3.18	2	2.3
				3					3	
	M1.4 x 0.3 (4)	MS04	M1.4	2	0.3	2.41	2.39	3.18	2	2.3
				3					3	
M1.6 x 0.35 (5)	MS04	M1.6	2	0.3	2.41	2.39	3.18	2	2.3	
			3					3		
M2 x 0.4 (5)	MS04	M2	2	0.3	3.18	3.16	3.96	2	3	
			3					3		

(1) MSO4 standoffs are designed for use in sheet hardness HRB 88 / HB 183 or less. For installation into harder sheets (up to HRC 36), contact our Tech Support line or your local representative.

(2) Unified ASME B1.1, 2B

(3) Miniature ISO 68-1, 5H

(4) Miniature ISO 68-1, 6H

(5) Metric ASME B1.13M, 6H

TA™/T4™ microPEM® TACKPIN® FASTENERS

Low Profile Head Provides Space Savings

- Suitable for installation into ductile materials
- Ideal for machined aluminum or steel HRB 88 or less
- Alternative to using micro-screws, eliminating the need to tap or use threaded inserts
- Reduce installation time vs. screws
- Lowers overall total installed costs from the elimination of the following:
 - Cost of screw patch to prevent loosening
 - Threaded inserts
 - Tapped holes
 - Installation Driver Bits
 - “Rework” due to cross-threading and/or driver bit “cam-out”

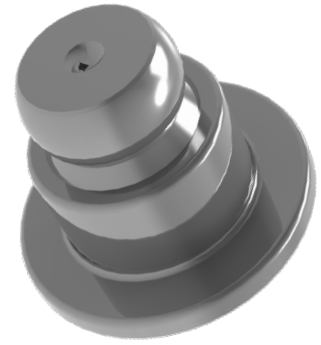

PART NUMBER DESIGNATION

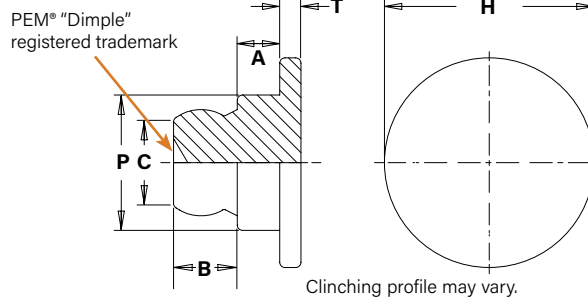
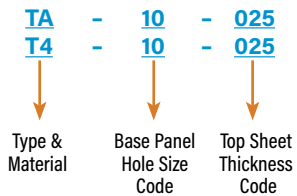

Comparison of TackPin® fastener to screw installation.

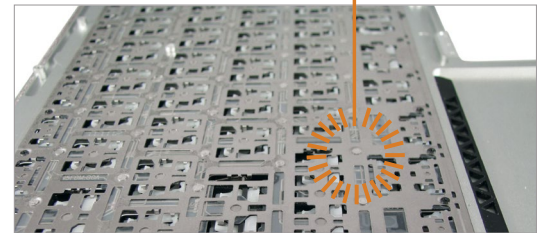
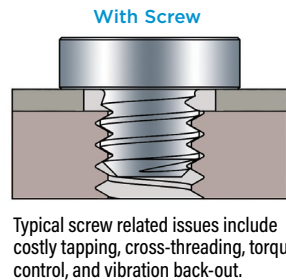
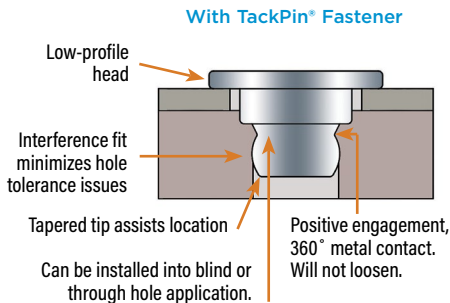

TackPin® and TackSert® fasteners have been specified to replace screws to attach a super-thin membrane to a very thin substrate in keyboards. The switch to TackPin® fasteners significantly reduced assembly costs.

Type	Base Panel Hole Size Code	Top Sheet Thickness Code	Top Sheet Thickness		Base Panel Min. Sheet Thickness ⁽¹⁾		Top Sheet Hole Size ±0.05 mm / ±.002"		Base Panel Hole Size -0.05 mm / -.002"		A ±0.025 mm / ±.001"		B ±0.075 mm / ±.003"		C Max.		H ±0.1 mm / ±.004"		P ±0.05 mm / ±.002"		T ±0.1 mm / ±.004"		Min. Dist. Hole To Edge		
			mm	in.	mm	in.	mm	in.	mm	in.	mm	in.	mm	in.	mm	in.	mm	in.	mm	in.	mm	in.			
TA	T4	10	025	0.2-0.28	.008-.011	0.89	.035	1.47	.058	1.02	.040	0.406	.016	0.610	.024	0.89	.035	2	.079	1.3	.051	0.2	.008	1	.039
TA	T4	10	050	0.48-0.56	.019-.022	0.89	.035	1.47	.058	1.02	.040	0.686	.027	0.610	.024	0.89	.035	2	.079	1.3	.051	0.2	.008	1	.039
TA	-	10	075	0.71-0.79	.028-.031	0.89	.035	1.47	.058	1.02	.040	0.914	.036	0.610	.024	0.89	.035	2	.079	1.3	.051	0.2	.008	1	.039

(1) 0.89 mm / .035" for blind holes and 0.5 mm / .020" for through holes.

Custom microPEM® TackPin® Fastener Solutions

Countersunk TackPin® Fastener



- Installs into a countersunk hole, replacing countersunk screws.
- Offers flush or near flush appearance.

Flush-head TackPin® Fastener



- TackPin installed into a thicker, softer top-sheet and pressed flush.

Large Head TackPin® Fastener

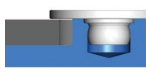

- TackPin with a large head installed into boss of bottom panel.
- Holds down top panel that is free to rotate around the boss.

Thin Sheet TackPin® Fastener

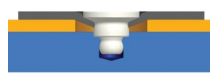

- Simple, press-in installation.
- Enables sheet-to-sheet attachment of multiple layers.
- Flush or sub-flush on both sides of sheet.
- Head mounts flush into top sheets as thin as .008"/0.2 mm.

TKA™/TK4™ microPEM® TACKSERT® PINS

Ideal for Plastic or Metal Castings

- Suitable for installation into brittle materials
- Low profile head provides space savings
- Alternative to using micro-screws, eliminating the need to tap or use threaded inserts
- Reduce installation time vs. screws
- Lowers overall total installed costs from the elimination of the following:
 - Cost of screw patch to prevent loosening
 - Threaded inserts
 - Tapped holes
 - Installation Driver Bits
 - "Rework" due to cross-threading and/or driver bit "cam-out"

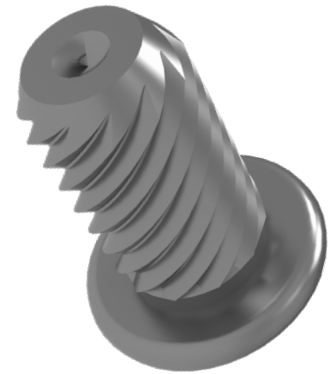

PART NUMBER DESIGNATION

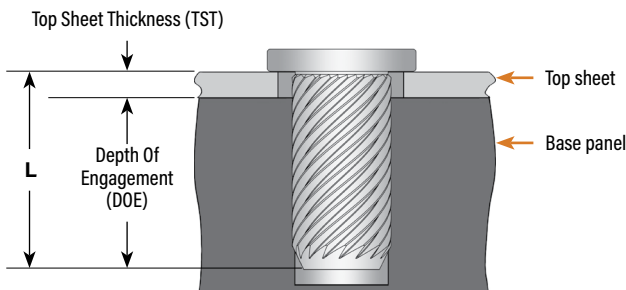
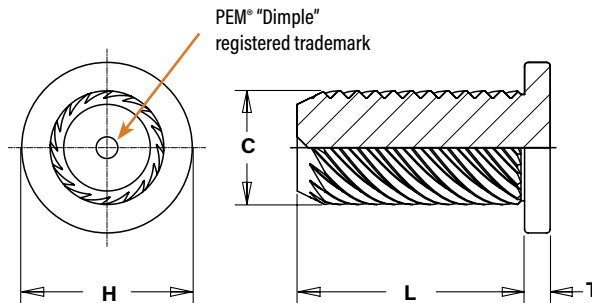
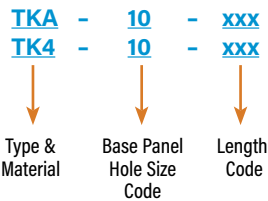

$DOE = L - TST$ $DOE \geq 0.8 \text{ mm} / .0315''$

For through hole applications
 $DOE - 0.25 \text{ mm} / .010'' = \text{Min. Sheet}$

For blind hole applications
 $DOE + 0.25 \text{ mm} / .010'' = \text{Min. Blind Hole Depth}$

Comparison of TackSert® pin to screw installation.

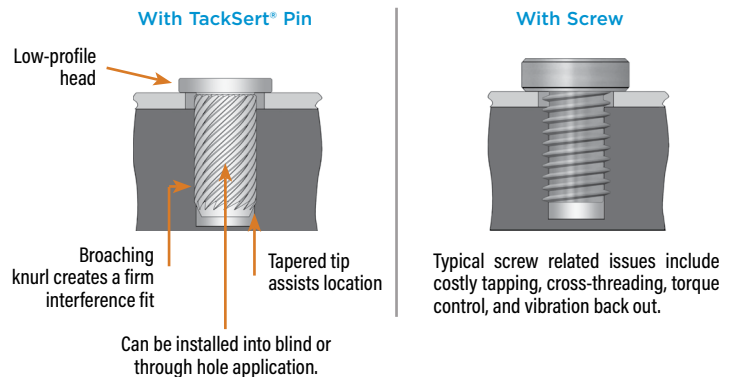

Type		Base Panel Hole Size Code	Length Code	Top Sheet Hole Size $\pm 0.05 \text{ mm} / \pm .002''$		Base Panel Hole Size $-0.05 \text{ mm} / -.002''$		Top Sheet Thickness Max.		C Max.		H $\pm 0.08 \text{ mm} / \pm .003''$		L $\pm 0.06 \text{ mm} / \pm .002''$		T $\pm 0.08 \text{ mm} / \pm .003''$		Min. Dist. Hole ϕ To Edge ⁽¹⁾	
Fastener Material	400 series stainless steel			mm	in.	mm	in.	mm	in.	mm	in.	mm	in.	mm	in.	mm	in.	mm	in.
TKA	TK4	10	100	1.3	.051	1	.039	0.2	.008	1.2	.047	1.8	.071	1	.039	0.27	.011	1.18	.047
TKA	TK4	10	150	1.3	.051	1	.039	0.7	.028	1.2	.047	1.8	.071	1.5	.059	0.27	.011	1.18	.047
TKA	TK4	10	200	1.3	.051	1	.039	1.2	.047	1.2	.047	1.8	.071	2	.079	0.27	.011	1.18	.047
TKA	TK4	10	250	1.3	.051	1	.039	1.7	.067	1.2	.047	1.8	.071	2.5	.098	0.27	.011	1.18	.047
TKA	TK4	10	300	1.3	.051	1	.039	2.2	.087	1.2	.047	1.8	.071	3	.118	0.27	.011	1.18	.047

(1) Minimum boss diameter is twice centerline-to-edge value.

TFA™ microPEM® FLEXTACK™ FASTENERS

The Belleville-Shaped Head Allows for Stack-Up Tolerance Relief in a Design

- Suitable for installation into ductile materials
- Ideal for machined aluminum HRB 50 or less
- Low profile head provides space savings
- Alternative to using micro-screws, eliminating the need to tap or use threaded inserts
- Reduce installation time vs. a screws
- Lowers overall total installed costs from the elimination of the following:
 - Cost of screw patch to prevent loosening
 - Threaded inserts
 - Tapped holes
 - Installation Driver Bits
 - “Rework” due to cross-threading and/or driver bit “cam-out”



PART NUMBER DESIGNATION

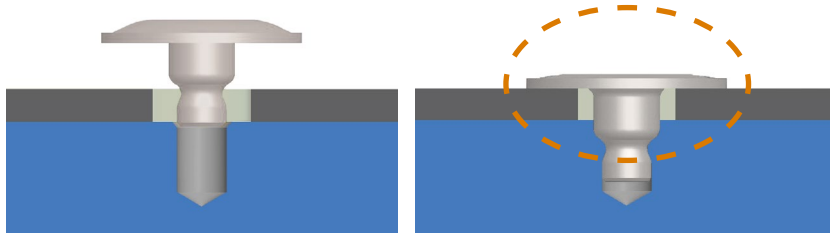
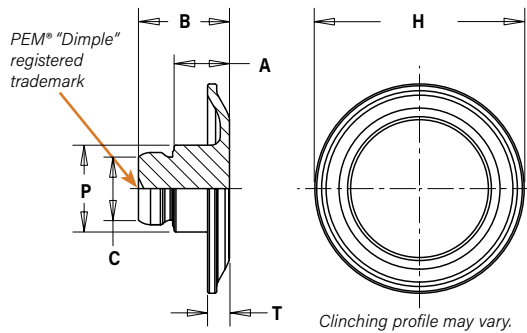
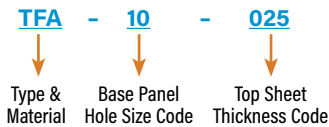

The Belleville shaped head flattens upon a simple press-in installation and draws panels together to accommodate vertical stack tolerances.

Type	Base Panel Hole Size Code	Top Sheet Thickness Code	Top Sheet Thickness		Base Panel Min. Sheet Thickness ⁽¹⁾		Top Sheet Hole Size ±0.05 mm / ±.002"		Base Panel Hole Size -0.05 mm / -.002"		A ±0.04 mm / ±.0015"		B ±0.08 mm / ±.003"		C Max.		H ±0.1 mm / ±.004"		P ±0.05 mm / ±.002"		T ±0.1 mm / ±.004"		Min. Dist. Hole \varnothing To Edge	
			mm	in.	mm	in.	mm	in.	mm	in.	mm	in.	mm	in.	mm	in.	mm	in.	mm	in.	mm	in.		
TFA	10	025	0.18 - 0.28	.007 - .011	0.89	.035	1.47	.058	1.02	.040	0.67	.026	1.16	.046	0.89	.035	2.91	.115	1.21	.048	0.3	.012	1	.039
TFA	10	035	0.28 - 0.38	.011 - .015	0.89	.035	1.47	.058	1.02	.040	0.77	.030	1.26	.050	0.89	.035	2.91	.115	1.21	.048	0.3	.012	1	.039
TFA	10	045	0.38 - 0.48	.015 - .019	0.89	.035	1.47	.058	1.02	.040	0.87	.034	1.37	.054	0.89	.035	2.91	.115	1.21	.048	0.3	.012	1	.039
TFA	10	055	0.48 - 0.58	.019 - .023	0.89	.035	1.47	.058	1.02	.040	0.97	.038	1.47	.058	0.89	.035	2.91	.115	1.21	.048	0.3	.012	1	.039

(1) 0.89 mm / .035" for blind holes and 0.5 mm / .020" for through holes.

CDS™ microPEM® CLAMPDISK® FASTENERS

The CDS™ microPEM® ClampDisk® fastener presses straight onto a 1 mm pin to replace threads, adhesive, rivets and other small fasteners. The upward flanges of the disk grip onto the pin and prevent push-off while the downward flanges flex and generate clamp load.

- Clamp load generation
- Simple installation
- Removability
- Works with multiple panels of any material
- Limited installation stress to assemble
- Tamper resistant

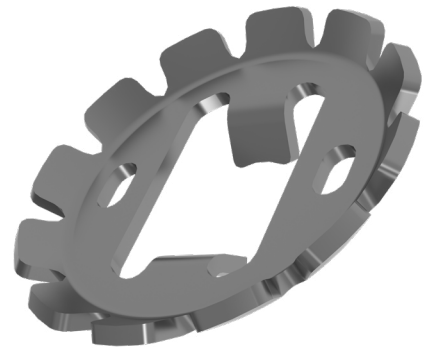

PART NUMBER DESIGNATION

CD **S** - **100**

↓ ↓ ↓

Type Material Pin Diameter Code

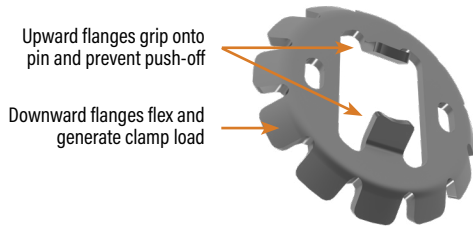
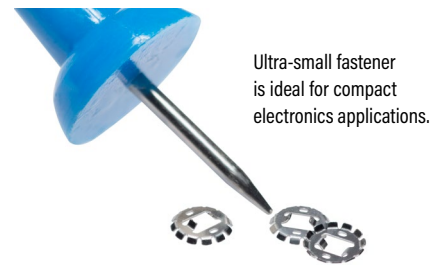
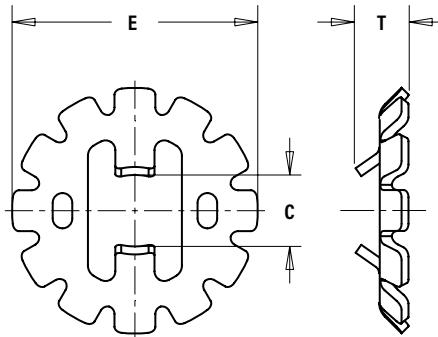

The ClampDisk® fastener can be used with a self-clinching pin. Contact techsupport@pemnet.com for information on pin material options.

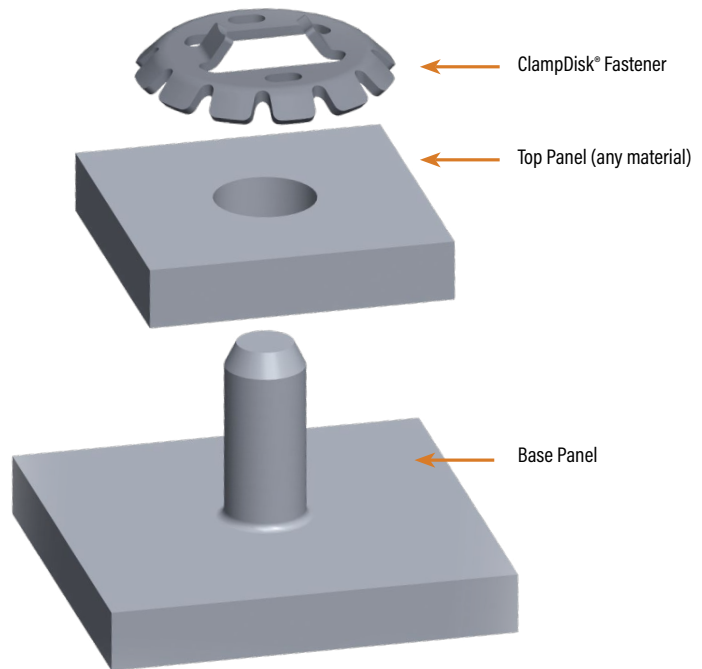

Pin Hardness limit: HRB 90 / HB 192

All dimensions are in millimeters.

METRIC	Type and Material	Pin Diameter Code	Pin Diameter +0.05 -0.03	Pin Length Min.	C Nom.	E Nom.	T Nom.
	CDS	100	1	0.8	0.91	3.2	0.69

MSIA™/MSIB™ microPEM® INSERTS FOR PLASTICS

- Symmetrical design eliminates the need for orientation
- Provides excellent performance in wide range of plastics
- Aluminum inserts offer light weight, lead-free alternative



PART NUMBER DESIGNATION

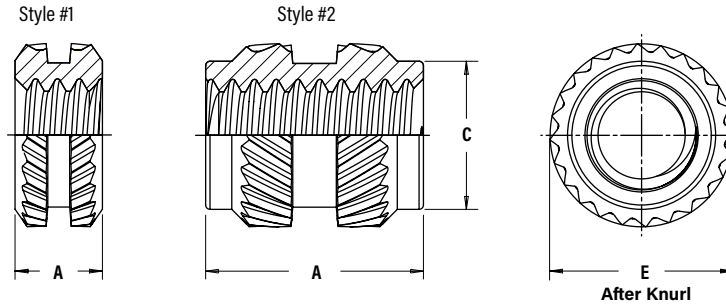
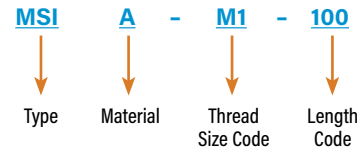

All dimensions are in millimeters.

METRIC	Thread Size x Pitch	Type		Thread Code	Length Code	A ±0.1	E ± 0.1	C Max.	Mounting Hole in Material		
		Aluminum	Brass						Min. Wall Thickness (6)	Hole Depth Min.	Hole Diameter +0.05
	M1 x 0.25 (3)	MSIA	MSIB	M1	100(1)	1	2.1	—	0.7	1.77	1.75
250(2)					2.5	1.75		3.27			
M1.2 x 0.25 (3)	MSIA	MSIB	M1.2	100(1)	1	2.1	—	0.7	1.77	1.75	
				250(2)	2.5		1.75		3.27		
M1.4 x 0.3 (4)	MSIA	MSIB	M1.4	150(2)	1.5	2.5	2.15	0.8	2.27	2.15	
				300(2)	3		3.77				
M1.6 x 0.35 (5)	MSIA	MSIB	M1.6	150(2)	1.5	2.5	2.15	0.8	2.27	2.15	
				300(2)	3		3.77				
M2 x 0.4 (5)	MSIA	MSIB	M2	300(2)	3	3.2	2.85	1.6	3.77	2.85	
				400(2)	4		4.77				

(1) Style #1 - length codes less than 150

(2) Style #2 - length codes 150 and greater

(3) Metric ISO 68-1, 5H

(4) Metric ISO 68-1, 6H

(5) Metric ASME B1.13M, 6H

(6) Refers to wall thickness of boss as tested in ABS and polycarbonate.

MSOFS™ microPEM® FLARING STANDOFFS

- MSOFS™ microPEM® flaring standoffs attach permanently in thin panels
- No minimum sheet thickness
- Can be installed into any type or hardness of panel, including metal, plastic and PC board
- Flaring feature allows for captivation of multiple panels
- Fastener captivation method allows for reduced centerline-to-edge designs



PART NUMBER DESIGNATION

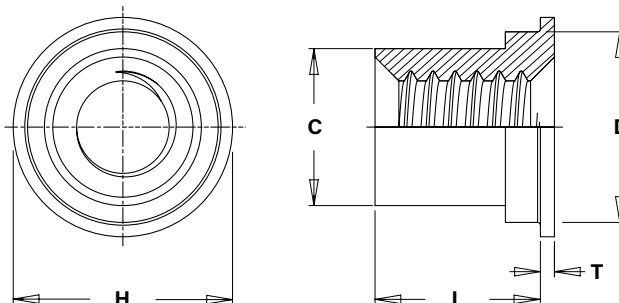
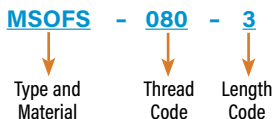

Alternative thin sheet clinch fastener solutions

Standoff for sheets as thin as 0.1 mm



Patent pending

Standoff for sheets as thin as 0.2 mm



Contact techsupport@pemnet.com for more information.

All dimensions are in inches.

UNIFIED	Thread Size	Type	Thread Code	Length Code	Sheet Thickness	Hole Size in Sheet +0.002 -0.000	C Max.	D Max.	H Nom.	L +0.002 -0.003	T ±0.002	Min. Dist. Hole \varnothing to Edge
	.060-80 (#0-80) ⁽¹⁾	MSOFS	080	3 4	.008 - .012	.118	.094	.117	.138	.093 .125	.010	.069
.086-56 (#2-56) ⁽¹⁾	MSOFS	256	3 4	.008 - .012	.138	.113	.137	.157	.093 .125	.010	.079	

All dimensions are in millimeters.

METRIC	Thread Size x Pitch	Type	Thread Code	Length Code	Sheet Thickness	Hole Size in Sheet +0.05	C Max.	D Max.	H Nom.	L +0.05 -0.08	T ±0.05	Min. Dist. Hole \varnothing to Edge
	M1 x 0.25 ⁽²⁾	MSOFS	M1	2 3	0.2 - 0.3	3	2.39	2.97	3.5	2 3	0.25	1.75
M1.2 x 0.25 ⁽²⁾	MSOFS	M1.2	2 3	0.2 - 0.3	3	2.39	2.97	3.5	2 3	0.25	1.75	
M1.4 x 0.3 ⁽³⁾	MSOFS	M1.4	2 3	0.2 - 0.3	3	2.39	2.97	3.5	2 3	0.25	1.75	
M1.6 x 0.35 ⁽⁴⁾	MSOFS	M1.6	2 3	0.2 - 0.3	3.5	2.87	3.48	4	2 3	0.25	2	
M2 x 0.4 ⁽⁴⁾	MSOFS	M2	2 3	0.2 - 0.3	3.5	2.87	3.48	4	2 3	0.25	2	

(1) Internal, ASME B1.1, 2B

(2) Metric ISO 68-1, 5H

(3) Metric ISO 68-1, 6H

(4) Metric ASME B1.13M, 6H

SMTSO™ microPEM® SURFACE MOUNT FASTENERS

- Hex shaped barrel provides optimal size/performance
- Provided on tape and reel
- Reduces board handling
- Can be installed automatically



Double Notch Registered Trademark Metric -1 length not marked

PART NUMBER DESIGNATION

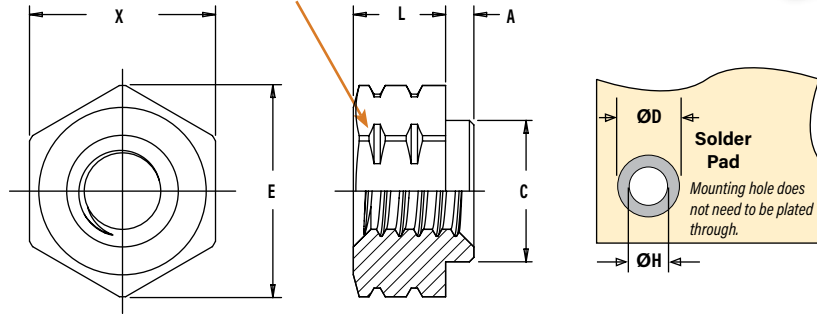
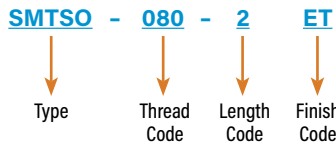

All dimensions are in inches.

UNIFIED	Thread Size	Type	Thread Code	Length Code	Min. Sheet Thickness	A Max.	C Max.	E Ref.	L ±.003	X Nom.	ØH Hole Size In Sheet +.003-.000	ØD Min. Solder Pad
	.060-80 (#0-80) (1)	SMTSO	080	2 4	.020	.019	.095	.144	.062 .125	.125	.098	.165

All dimensions are in millimeters.

METRIC	Thread Size	Type	Thread Code	Length Code	Min. Sheet Thickness	A Max.	C Max.	E Ref.	L ±0.08	X Nom.	ØH Hole Size In Sheet +0.08	ØD Min. Solder Pad
	S1 (2)	SMTSO	M1	M1	1	0.5	0.48	2.41	3.66	1	3.18	2.5
2					2							
3					3							
S1.2 (2)	SMTSO	M1.2	M1.2	1	0.5	0.48	2.41	3.66	1	3.18	2.5	4.19
				2					2			
				3					3			
S1.4 (2)	SMTSO	M1.4	M1.4	1	0.5	0.48	2.41	3.66	1	3.18	2.5	4.19
				2					2			
				3					3			
M1.6 x 0.35 (3)	SMTSO	M1.6	M1.6	1	0.5	0.48	2.41	3.66	1	3.18	2.5	4.19
				2					2			
				3					3			

(1) Unified ASME B1.1, 2B

(2) Miniature ISO 1501, 4H6

(3) Metric ASME B1.13M, 6H

NUMBER OF PARTS PER REEL / PITCH (MM) FOR EACH SIZE

Thread/Thru-Hole Size	Length Code							
	1	2	3	4	6	8	10	12
080	—	3500 / 8	—	2000 / 8	—	—	—	—
M1, M1.2, M1.4, M1.6	3500 / 8	2500 / 8	2000 / 8	—	—	—	—	—

A polyimide patch is supplied to allow for reliable vacuum pickup. Fasteners are also available without a patch which may provide a lower cost alternative, depending on your installation methods/requirements.

Packaged on 330 mm recyclable reels. Tape width is 24 mm. Reels conform to EIA-481.



CAPABILITIES

INTERNAL / EXTERNAL FASTENERS

The screws are available with internal or external driver and thread size variability.

- From M1.0 Internal/M1.2 External
- Drive variability - internal cross drive or external drive
- Locking patch on external thread

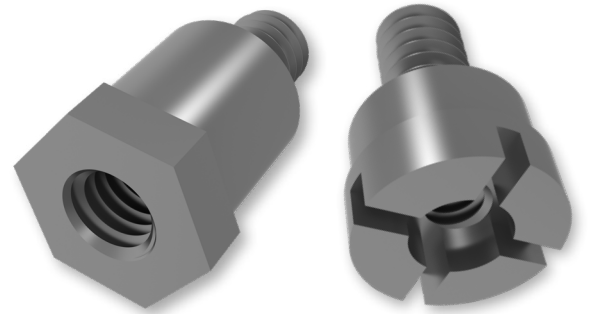

Internal/External Fastener with External Drive

Internal/External Fastener with Internal Cross Drive

MICROSCREW

Microscrews are optimal for compact component attachment applications where thinner sheets and wall thicknesses are used.

- Thread sizes from M0.8
- As short as 1mm
- Various materials - stainless, steel, aluminum
- Various drive types, head styles, plating options
- Locking patch



ZACKSERT™ FASTENER

The ZackSert™ fastener is a smart alternative for achieving a stronger fastening joint, replacing machining and tapping screw bosses, which are timely and not optimal.

- Eliminates need for machined and tapped a screw bosses
- Stronger heat-treated, stainless steel threads
- Capable of dropping into current boss geometry
- Similar automated installation process as Tack products



PennEngineering is a licensee of Acument Global Technologies (Torx®, Torx Plus®), Reminc (REMFORM®, TAPTITE 2000®, FASTITE 2000®), EJOT® (PT® and DELTA PT®) and OSG Corporation and OSG System Products Co., Ltd. (Microstix®).

MATERIAL AND FINISH SPECIFICATIONS

Type	Fastener Materials							Standard Finishes ⁽¹⁾			For Use in Sheet Hardness: ⁽²⁾						
	Carbon Steel	Age Hardened A286 Stainless Steel	300 Series Stainless Steel	Hardened 400 Series Stainless Steel	Hardened Aluminum	Aluminum	Free-Machining Leaded Brass	Passivated and/or Tested Per ASTM A380	Electro-Plated Tin ASTM B 545, Class A, with Clear Preservative Coating, Annealed ⁽³⁾	Plain Finish	HRB 50 / HB 89 or Less	HRB 88 / HB 183 or Less	HRB 92 / HB 202 or Less	PC Board	Plastics	Castings and Brittle Materials	Any Panel Hardness
MPP		▪						▪				▪					
MSO4				▪				▪				▪					
SMTSO	▪								▪				▪				
TA					▪				▪	▪							
T4				▪				▪			▪						
TKA					▪				▪				▪	▪			
TK4				▪				▪					▪	▪	▪		
TFA					▪				▪	▪							
TS4				▪				▪			▪						
CDS			▪					▪									▪ ⁽⁴⁾
MSIA						▪			▪						▪		
MSIB							▪		▪						▪		
MSOFS			▪					▪									▪
Part Number Codes For Finishes								None	ET	None							

(1) See PEM Technical Support section of our web site for related plating standards and specifications.

(2) HRB - Hardness Rockwell "B" Scale. HB - Hardness Brinell.

(3) Optimal solderability life noted on packaging.

(4) The top panel can be any material and the pin must be under a max hardness of HRB 90 / HB 192.

A NOTE ABOUT HARDENED 400 SERIES STAINLESS STEEL

In order for self-clinching fasteners to work properly, the fastener must be harder than the sheet into which it is being installed. In the case of stainless steel panels, fasteners made from 300 Series Stainless Steel do not meet this hardness criteria. It is for this reason that 400 series fasteners (MSO4, T4, TK4 and TS4) are offered. However, while these 400 Series fasteners install and perform well in 300 Series stainless sheets they should not be used if the end product:

- Will be exposed to any appreciable corrosive presence
- Requires non-magnetic fasteners
- Will be exposed to any temperatures above 300°F (149°C)

If any of the these are issues, please contact techsupport@pemnet.com for other options.

INSTALLATIONS

MPP PINS

1. Prepare properly sized mounting hole in sheet. Do not perform any secondary operations such as deburring.
2. Insert pin through mounting hole (preferably the punch side) of sheet and into anvil hole.
3. With installation punch and anvil surfaces parallel, apply squeezing force to embed the head of the pin flush in the sheet.

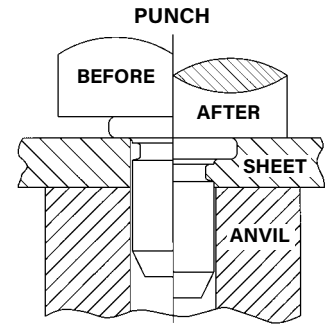

PEMSERTER® Installation Tooling

Type	Pin Diameter Code	Anvil Dimensions (mm)		Anvil Part Number	Punch Part Number
		B ±0.02			
MPP	1MM	1.07		8014168	8014167
MPP	1.5MM	1.57		8014169	8014167
MPP	2MM	2.07		8014170	8014167

Recommended Installation Anvil

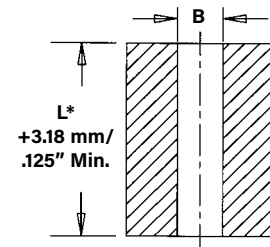

*See page 3 for "L".

Requirements for Installation into Stainless Steel

1. Sheet hardness must be less than the specified limit for the fastener.
2. Panel material should be in the annealed condition.
3. Fastener should be installed in punch side of hole.
4. Mounting hole punch should be kept sharp to minimize work hardening around hole.
5. Maintain the mounting hole punch diameter to no greater than .025 mm / .001" over the minimum recommended mounting hole.
6. When installing fastener adjacent to bends or other highly cold-worked areas, use the C/L to edge values listed in the catalog.

MSO4 STANDOFFS

1. Prepare properly sized mounting hole in sheet. Do not perform any secondary operations such as deburring.
2. Insert standoff through mounting hole (preferably the punch side) and into anvil as shown in drawing.
3. With installation punch and anvil surfaces parallel, apply only enough squeezing force to embed the head of the standoff flush in the sheet.

PEMSERTER® Installation Tooling

UNIFIED	Type	Thread Code	Anvil Dimensions (inches)		Anvil Part Number	Punch Part Number
			A	B		
	MSO4	080	.112 - .114	.097 - .099	8015796	975200997
	MSO4	256	.142 - .144	.127 - .129	8015797	975200997

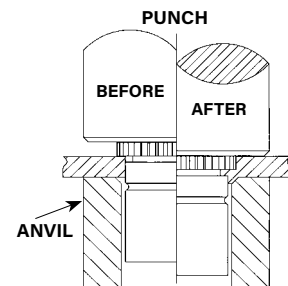

Recommended Installation Anvil

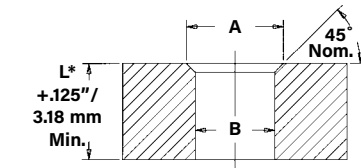

*See page 3 for "L".

METRIC	Type	Thread Code	Anvil Dimensions (mm)		Anvil Part Number	Punch Part Number
			A	B		
	MSO4	M1	2.84 - 2.89	2.46 - 2.51	8015796	975200997
	MSO4	M1.2	2.84 - 2.89	2.46 - 2.51	8015796	975200997
	MSO4	M1.4	2.84 - 2.89	2.46 - 2.51	8015796	975200997
	MSO4	M1.6	2.84 - 2.89	2.46 - 2.51	8015796	975200997
	MSO4	M2	3.6 - 3.65	3.22 - 3.27	8015797	975200997

TA/T4 FASTENERS

1. Prepare properly sized mounting hole in top sheet and base panel. Base panel mounting hole can be through or blind.
2. Place top sheet and base panel in proper position.
3. Place fastener through hole in top sheet and into mounting hole of base panel (preferably the punch side) of base panel.
4. With installation punch and anvil surfaces parallel, apply squeezing force until the head of the fastener contacts the top sheet.

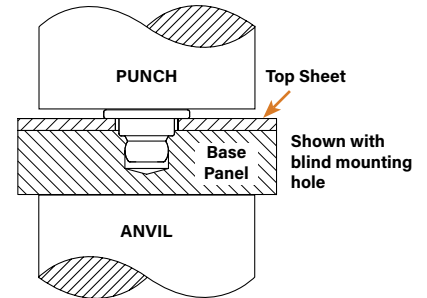

PEMSERTER® Installation Tooling

Size	Manual Punch Part Number	Manual Anvil Part Number
TA/T4-10-025	8014167	975200046
TA/T4-10-050		
TA/T4-10-075		

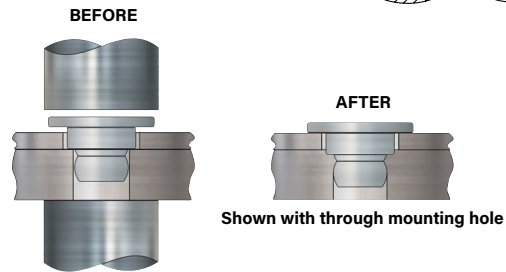

TKA/TK4 PINS

1. Prepare properly sized mounting hole in top sheet and base panel. Base panel mounting hole can be through or blind.
2. Place top sheet and base panel in proper position.
3. Place pin through hole in top sheet and into mounting hole of base panel.
4. With installation punch and anvil surfaces parallel, apply squeezing force until the head of the pin contacts the top sheet.

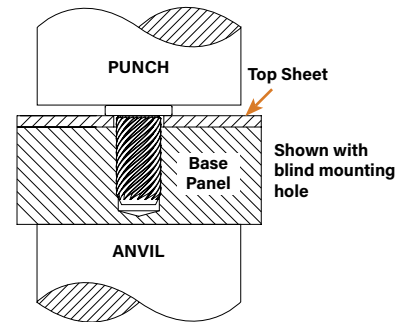

PEMSERTER® Installation Tooling

Size	Punch Part Number	Anvil Part Number
TKA/TK4-10-100	8014167	975200046
TKA/TK4-10-150		
TKA/TK4-10-200		
TKA/TK4-10-250		
TKA/TK4-10-300		

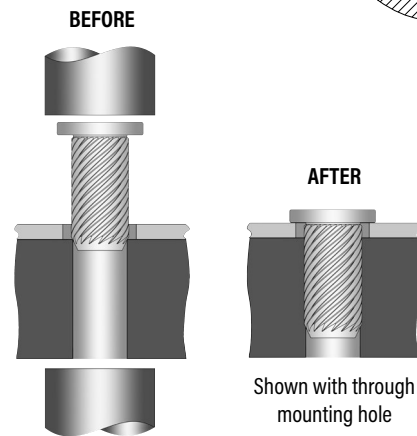

TFA FASTENERS

1. Prepare properly sized mounting hole in top sheet and base panel. Base panel mounting hole can be through or blind.
2. Place top sheet and base panel in proper position.
3. Place fastener through hole in top sheet and into mounting hole (preferably the punch side) of base panel.
4. With installation punch and anvil surfaces parallel, apply squeezing force until the head of the fastener flattens and contacts the top sheet.

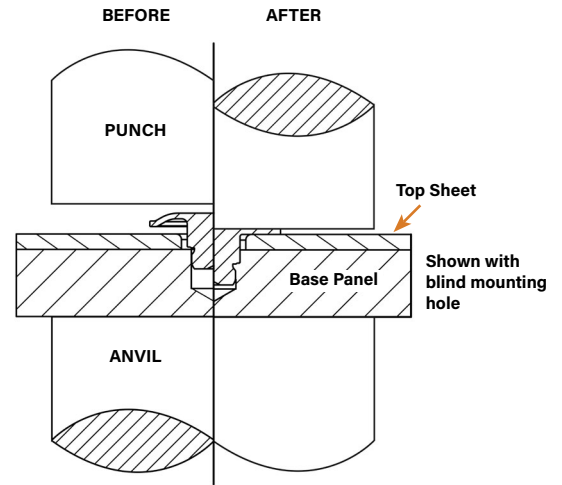

PEMSERTER® Installation Tooling

Size	Manual Punch Part Number	Manual Anvil Part Number
TFA-10-025	8014167	975200046
TFA-10-035		
TFA-10-045		
TFA-10-055		

TS4 FASTENERS

1. Prepare properly sized mounting hole in top sheet and base panel. Base panel mounting hole can be through or blind.
2. Place sheet and base panel in proper position.
3. Place fastener through hole in sheet and into mounting hole (preferably the punch side) of base panel.
4. With punch and anvil surfaces parallel, apply squeezing force until the head of the fastener contacts the top sheet.

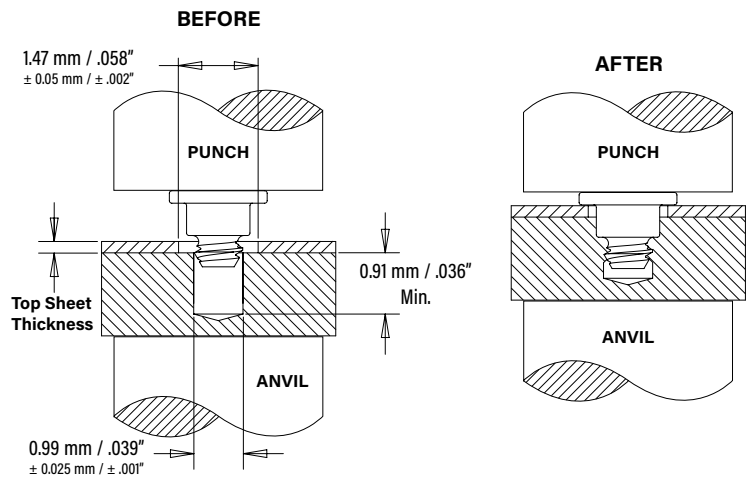

Re-installation (if necessary)

1. Place sheet and base panel in proper position.
2. Place adhesive into base panel mounting hole.
3. Place fastener through hole in top sheet and into mounting hole of base panel.
4. Screw in fastener with 2IP Torx Plus driver.

PEMSERTER® Installation Tooling

Part Number	Punch Part Number	Anvil Part Number
TS4-10-025	8014167	975200046
TS4-10-050		

CDS FASTENERS

1. Place ClampDisk® fastener over a pin.
2. With the installation punch and anvil surfaces parallel, apply squeezing force until the punch contacts the mounting sheet. The drawings at the right indicate suggested tooling for applying these forces.

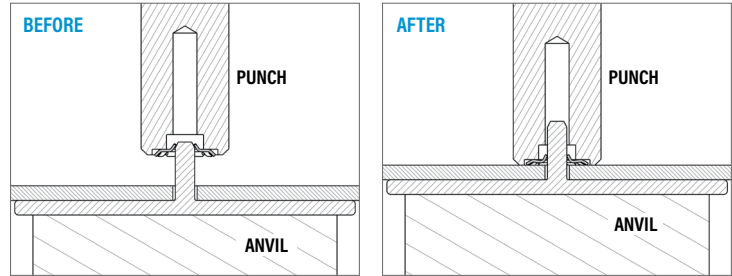

Removal

For service or maintenance, the ClampDisk® fastener can be easily removed with a sharp edge tool. For reassembly, simply install a new fastener.

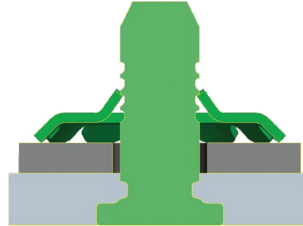

The PEM® ClampDisk® fastener can be installed onto a grooved pin for increase strength and allow installation onto any material. For more information, contact techsupport@pemnet.com.

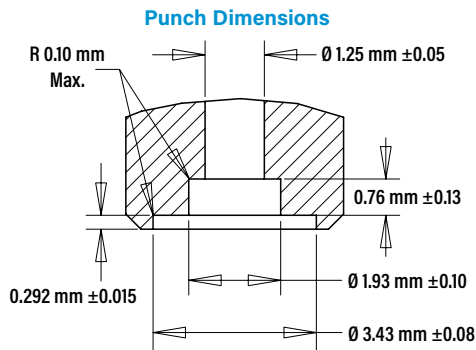

Installation Tooling

Fastener Part Number	Punch Part Number	Anvil Part Number
CDS-100	8025386	975200046

MSOFS STANDOFFS

1. Prepare properly sized mounting hole in sheet. Do not perform any secondary operations such as deburring.
2. Place the standoff into anvil recess and place the mounting hole over the standoff as shown in the drawing.
3. Using a punch flaring tool and a recessed anvil, apply squeezing force until punch contacts the sheet.

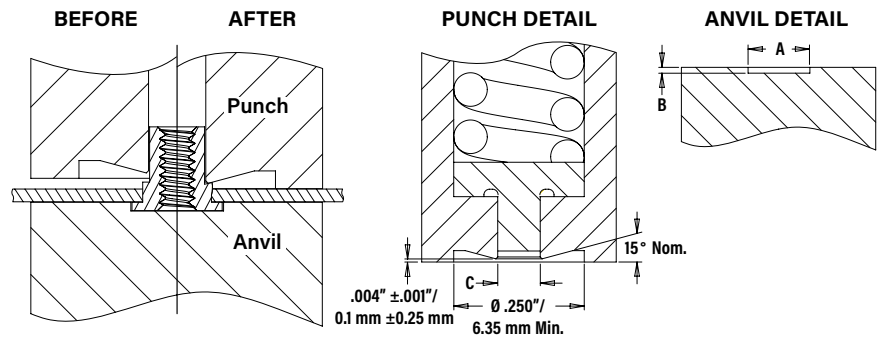

PEMSERTER® Installation Tooling

UNIFIED	Thread Code	Punch Dimensions (in.)		Anvil Dimensions (in.)		
		C +.001	Punch Part Number	A ±.001	B ±.001	Anvil Part Number
	080	.095	8020712	.143	.006	8019720
	256	.114	8020710	.163	.006	8019722

METRIC	Thread Code	Punch Dimensions (mm)		Anvil Dimensions (mm)		
		C +0.025	Punch Part Number	A ±.025	B ±.025	Anvil Part Number
	M1	2.41	8020712	3.64	0.15	8019720
	M1.2	2.41	8020712	3.64	0.15	8019720
	M1.4	2.41	8020712	3.64	0.15	8019720
	M1.6	2.9	8020710	4.14	0.15	8019722
	M2	2.9	8020710	4.14	0.15	8019722

SMTSO™ FASTENERS

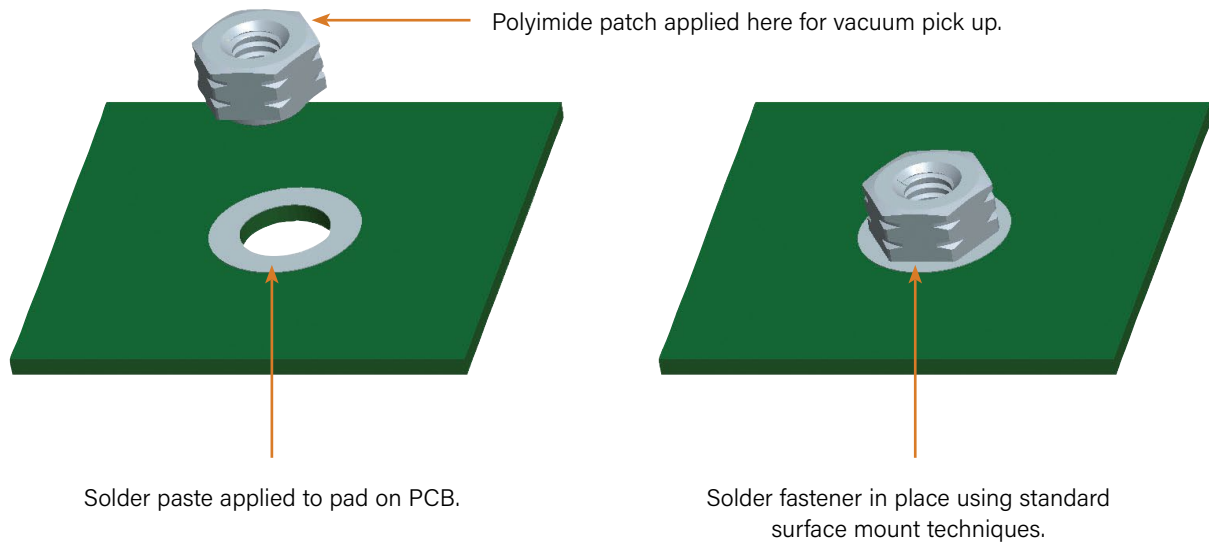

Number of parts per reel/pitch (mm) for each size

Thread Code	Length Code			
	1	2	3	4
080	—	3500 / 8	—	2000 / 8
M1, M1.2, M1.4, M1.6	3500 / 8	2500 / 8	2000 / 8	—

Packaged on 330mm recyclable reels.

Tape width is 16mm.

Supplied with polyimide patch for vacuum pick up.

Reels conform to EIA-481.

Installation notes

- For best results we recommend using a Haeger® or PEMSERTER® machine for installation of PEM self-clinching fasteners. Please check our website for more information.
- Visit the Animation Library on our website to view the installation process for select products.

PERFORMANCE DATA⁽¹⁾

MSO4 STANDOFFS

UNIFIED	Type	Thread Code	Max. Rec. Tightening Torque For Mating Screw (in. lbs.)	Sheet Thickness (in.)	Test Sheet Material			
					300 Series Stainless Steel			
					Installation (lbs.)	Pushout (lbs.)	Torque-out (in.lbs.) (2)	Pull-thru (lbs.) (2)
MSO4	080		.65	.013	2500	33	1.3	78
				.017	2500	45	2.2	
MSO4	256		1.3	.013	2500	33	2.2	110
				.017	2500	45	2.6	

METRIC	Type	Thread Code	Max. Rec. Tightening Torque For Mating Screw (N-m)	Sheet Thickness (mm)	Test Sheet Material			
					300 Series Stainless Steel			
					Installation (kN)	Pushout (N)	Torque-out (N-m) (2)	Pull-thru (N) (2)
MSO4	M1		0.019	0.3	11.1	150	0.15	350
				0.43	11.1	200	0.25	
MSO4	M1.2		0.036	0.3	11.1	150	0.15	350
				0.43	11.1	200	0.25	
MSO4	M1.4		0.057	0.3	11.1	150	0.15	350
				0.43	11.1	200	0.25	
MSO4	M1.6		0.084	0.3	11.1	150	0.15	350
				0.43	11.1	200	0.25	
MSO4	M2		0.175	0.3	11.1	150	0.25	500
				0.43	11.1	200	0.3	

MPP PINS

Type	Pin Diameter Code	Test Sheet Thickness	Installation (kN)	Pushout (N)
MPP	1MM	0.5mm stainless steel HRB 88	10	320
MPP	1.5MM	0.5mm stainless steel HRB 88	12	760
MPP	2MM	0.5mm stainless steel HRB 88	18	860

TA FASTENERS

Type	5052-H34 Aluminum			
	Installation		Pullout	
	N	lbs.	N	lbs.
TA-10-025	820	185	80	18
TA-10-050				
TA-10-075				

T4 FASTENERS

Type	300 Series Stainless Steel			
	Installation		Pullout	
	N	lbs.	N	lbs.
T4-10-025	2020	455	200	45
T4-10-050				

TKA/TK4 PINS

Type	Test Base Panel Material	Depth Of Engagement		Installation		Pullout	
		(mm)	(in.)	(N)	(lbs.)	(N)	(lbs.)
TKA-10	ABS	0.8	0.0315	133	30	9	2
		1	0.0394	133	30	14	3
		1.3	0.0492	133	30	19	4
		1.5	0.0590	178	40	24	6
		1.8	0.0708	178	40	31	7
		2	0.0787	222	50	35	8
		2.3	0.0886	222	50	41	9
TKA-10	Polycarbonate	0.8	0.0315	222	50	25	6
		1	0.0394	267	60	37	8
		1.3	0.0492	267	60	53	12
		1.5	0.0590	311	70	68	15
		1.8	0.0708	334	75	86	19
		2	0.0787	378	85	98	22
		2.3	0.0886	400	90	113	25
TK4-10	Magnesium Casting (AZ91D)	0.8	0.0315	445	100	29	7
		1	0.0394	489	110	43	10
		1.3	0.0492	534	120	61	14
		1.5	0.0590	578	130	78	18
		1.8	0.0708	623	140	99	22
		2	0.0787	667	150	113	25
		2.3	0.0886	712	160	131	29
		2.8	0.1102	801	180	169	38

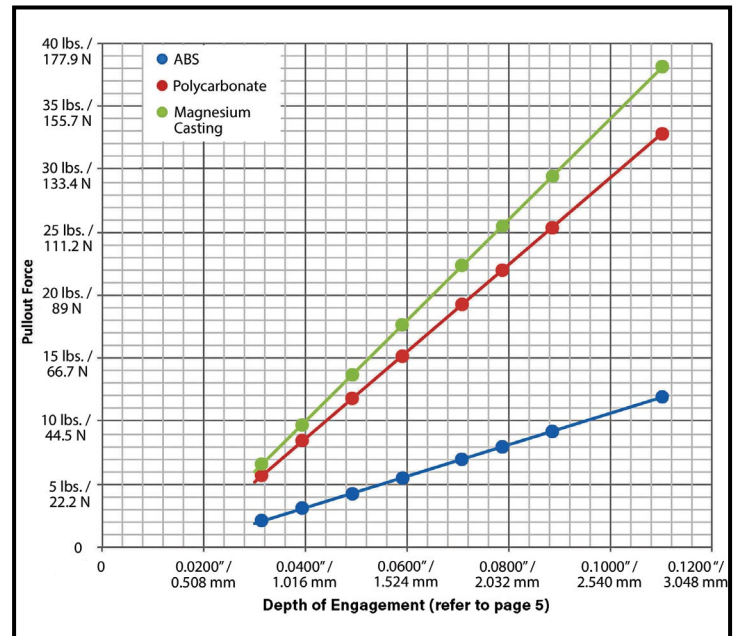

- (1) Published installation forces are for general reference. Actual set-up and confirmation of complete installation should be made by observing proper seating of fastener as described in the installation steps. Other performance values reported are averages when all proper installation parameters and procedures are followed. Variations in mounting hole size, sheet material, and installation procedure may affect performance. Performance testing this product in your application is recommended. We will be happy to provide technical assistance and/or samples for this purpose.
- (2) Performance in torque-out and pull-thru will depend on the strength and type of screw being used. In most cases the failure will be in the screw and not in the self-clinching standoff. Please contact our Applications Engineering group with any questions.

TFA FASTENERS

Type	5052-H34 Aluminum			
	Installation		Pullout	
	N	lbs.	N	lbs.
TFA-10-025	450	101	40	9
TFA-10-035				
TFA-10-045				
TFA-10-055				

TS4 FASTENERS

Part Number	Tested Top Sheet Thickness	5052-H34 Aluminum HRB 63 / HB 114						304 Stainless Steel HRB 89 / HB 187					
		Installation		Pullout ⁽¹⁾		Torque to Remove		Installation		Pullout ⁽¹⁾		Torque to Remove	
		(N)	(lbs.)	(N)	(lbs.)	(N-cm)	(in. oz.)	(N)	(lbs.)	(N)	(lbs.)	(N-cm)	(in. oz.)
TS4-10-025	0.254 mm / .01"	556	125	80	18	3.3	4.7	1423	320	125	28	4.6	6.5
TS4-10-050	0.533 mm / .021"												

CDS FASTENERS⁽²⁾

Part Number	Test Pin Material	Installation (kN) ⁽¹⁾	Pull-off (N)	Clamp Load (N)
CDS-100	6061-T6 Aluminum	0.33	18.1	7

MSOFS STANDOFFS

UNIFIED	Type	Thread Code	Max. Rec. Tightening Torque For Mating Screw (in. lbs.)	Test Sheet Material		
				.008" 300 Series Stainless Steel		
				Installation (lbs.)	Pushout (lbs.)	Torque-out (in.lbs.) ⁽³⁾
	MSOFS	080	.65	1500	69.8	1.29
	MSOFS	256	1.3	1800	91.2	1.29

METRIC	Type	Thread Code	Max. Rec. Tightening Torque For Mating Screw (N-m)	Test Sheet Material		
				0.2 mm 300 Series Stainless Steel		
				Installation (kN)	Pushout (N)	Torque-out (N-m) ⁽³⁾
	MSOFS	M1	0.019	6.67	311	0.146
	MSOFS	M1.2	0.036	6.67	311	0.146
	MSOFS	M1.4	0.057	6.67	311	0.146
	MSOFS	M1.6	0.084	8	406	0.146
	MSOFS	M2	0.175	8	406	0.146

- (1) Pullout after initial installation.
- (2) Specially designed installation punch prevents over-installation and damage to the fastener.
- (3) Torque-out performance will depend on the strength and type of screw being used. In most cases, the screw threads will fail before the insert threads.

PERFORMANCE DATA⁽¹⁾

MSIA/MSIB INSERTS

METRIC	Type	Thread Code	Length Code	Test Sheet Material			
				ABS		Polycarbonate	
				Pullout (N)	Torque-out (N-cm) ⁽¹⁾	Pullout (N)	Torque-out (N-cm) ⁽¹⁾
MSIA/MSIB	M1		100	50	3.5	50	4.5
			250	150	10	200	12
MSIA/MSIB	M1.2		100	50	3.5	50	4.5
			250	150	10	200	12
MSIA/MSIB	M1.4		150	100	15	140	15
			300	330	30	400	30
MSIA/MSIB	M1.6		150	100	15	140	15
			300	330	30	400	30
MSIA/MSIB	M2		300	335	35	410	33
			400	470	40	595	35

For testing purposes, inserts were installed using heat stake equipment into a flat sheet.

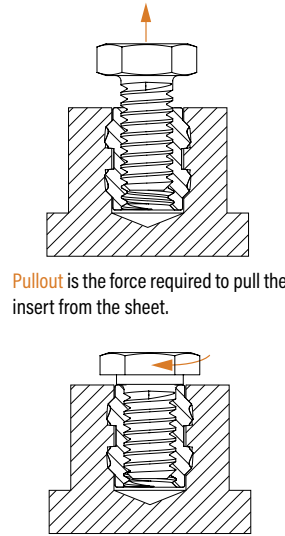

Pullout is the force required to pull the insert from the sheet.

Torque-out is the torque required to turn the insert in the parent material after installation without inducing clamp load on the fastener.

HOLE PREPARATION GUIDELINES

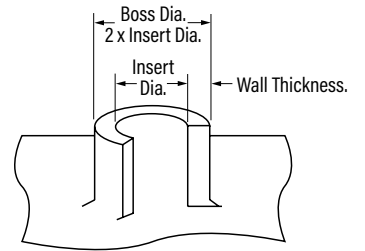

Thinner walls and bosses may be used but will affect performance.

SMTSO⁽²⁾⁽³⁾ FASTENERS

Type and Size	Test Sheet Material			
	.062" Single Layer RF-4			
	Pushout (lbs.)	Pushout (N)	Torque-out (in. lbs.)	Torque-out (N-m)
SMTSO-080	85.1	378.7	4.94	0.56
SMTSO-M1				
SMTSO-M1.2				
SMTSO-M1.4				
SMTSO-M1.6				

SMTSO TESTING CONDITIONS

Oven	Quad ZCR convection oven with 4 zones
High Temp	518° F / 270° C
Board Finish	62% Sn, 38% Pb
Screen Printer	Ragin Manual Printer
Vias	None
Spokes	2 Spoke Pattern
Paste (lead-free)	Amtech NC559LF Sn96.5/3.0Ag/0.5Cu (SAC305)
Stencil	.0067" / 0.17mm thick

- (1) Torque-out performance will depend on the strength and type of screw being used. In most cases, the screw threads will fail before the insert threads.
- (2) With lead-free paste. Average values of 30 test points. The data presented here is for general comparison purposes only. Actual performance is dependent upon application variables. We will be happy to provide samples for you to install. If required, we can also test your installed hardware and provide you with the performance data specific to your application.
- (3) Further testing details can be found in our web site's literature section.

To be sure you are getting genuine PEM® brand fasteners, look for the unique PEM® product markings and identifiers

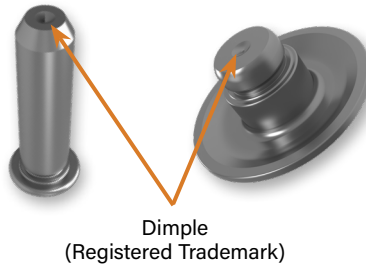



NORTH AMERICA

Danboro, Pennsylvania USA
info@pemnet.com
+1-215-766-8853
800-237-4736 (USA)

Querétaro, Mexico
JMayagoitia@pemnet.com

EUROPE

Galway, Ireland
europe@pemnet.com
+353-91-751714

ASIA/PACIFIC

Japan
daiyou@pemnet.jp
+042-798-7177

Singapore
singapore@pemnet.com
+65-6645-9271

Kunshan, China
salesgreaterchina@pemnet.com
+0512-57269300

Suwon, South Korea
korea@pemnet.com
+82-10-2992-8597

CONNECT WITH PENNINGENGINEERING®

Follow us for the latest company and product news, bulletin updates, tech tips, videos, and more.

